



User's Manual



MPPT SOLAR CHARGE CONTROLLER

Your battery guard

Dear users,

Thank you for choosing our product !

Important Safety Instructions

Please keep this manual for future review.

This manual contains all instructions of safety, installation and operation for Tracer Dream 150V series Maximum Power Point Tracking (MPPT) controller ("the controller" as referred to in this manual).

General Safety Information

- ① Read carefully all the instructions and warnings in the manual before installation.
- ② No user serviceable components inside the controller. Don't disassemble or attempt to repair the controller.
- ③ Mount the controller indoors. Avoid exposure the components and do not allow water to enter the controller.
- ④ Install the controller in a well ventilated place. The controller's heat sink may become very hot during operation.
- ⑤ Suggest installing appropriate external fuses/breakers.
- ⑥ Make sure to switch off all PV array connections and the battery fuse or breakers before controller installation and adjustment.
- ⑦ Power connections must remain tight to avoid excessive heating from loose connection.

Explanation of symbols

- To enable users to use the product efficiently and ensure personal and property safety, please read related literature accompanying the following symbols.
- Please read the literature accompanying the following symbols.



Tips: Indicate recommendations that can be referred to.

IMPORTANT: Indicates a critical tip during the operation, if ignored, may cause the device to run in error.



CAUTION: Indicates potential hazards, if not avoided, may cause the device damaged.



WARNING: Indicates the danger of electric shock; if not avoided, it would cause casualties.

1. General Information

1.1 Overview

iTD series controller is based on Based on single phase synchronous rectification technology and advanced MPPT control algorithm, adopt co-negative design, with LED displaying running status. The MPPT control algorithm can minimize the maximum power point loss rate and loss time, quickly track the maximum power point of the PV array and obtain the maximum energy from solar modules under any conditions; and can increase the ratio of energy utilization in the solar system by 20%-30% compared with a PWM charging method.

The iTD series controller owns a self-adaptive three-stage charging mode based on a digital control circuit. This function can effectively prolong the battery's lifespan and significantly improve the system's performance.

Limiting the charging power and reducing charging power functions ensure the system stable with over PV modules in high temperature environment.

With comprehensive electronic fault self-detecting functions and powerful electronic protection functions built inside the controller, component damage caused by installation errors or system failures can be avoided to the greatest extent possible.

The RS485 port with standard MODBUS communication protocol and 5V power supply is easy to expand the application and connect the external Bluetooth/WiFi module. The controller can be widely used for various applications, e.g., solar RV, household system and field monitoring, etc.

Features :

- With the advanced dual-peak or multi-peak tracking technology, when the solar panel is shadowed or part of the panel fails resulting in multiple peaks on the I-V curve, the controller is still able to accurately track the maximum power point.
- Advanced MPPT technology, with efficiency no less than 99.5%
- Maximum DC/DC conversion efficiency of 98%
- Ultra-fast tracking speed and guaranteed tracking efficiency
- Advanced MPPT control algorithm to minimize the MPP loss rate and loss time
- Wide MPP operating voltage range
- Limit charging power & current over rated range. When the solar panel power exceeds a certain level and the charging current is larger than the rated current, the controller will automatically lower the charging power and bring the charging current to the rated level.
- Support the lead-acid, gel, flooded with the needed Temp. compensation and support lithium batteries starting from solar panel
- Real-time working record function
- Power reduction automatically over temperature range
- TVS lighting protection.
- Support parameters setting via the iConnect App

1.2 Characteristics

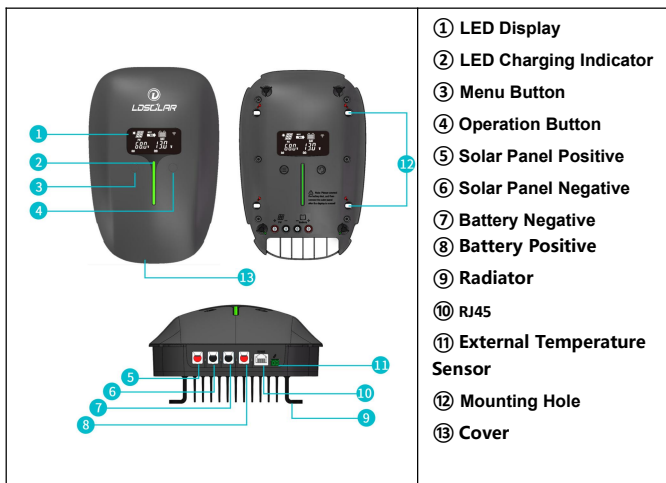

Figure 1-1 Product Characteristics

★If the temperature sensor is short-circuited or damaged, the controller will charge at the default temperature setting of 25°C.

1.3 Battery Charging Stage

The controller has a 3 stages battery charging algorithm (Bulk Charging, Boost Charging and Float Charging) for rapid, efficient, and safe battery charging.

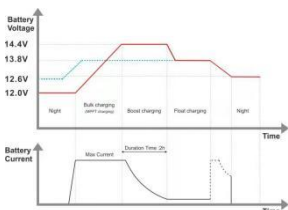

Figure 1-5 Lead acid Battery charging stage Curve

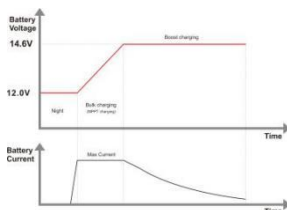

Figure 1-6 Li Battery charging stage curve

(1) Bulk Charging

In this stage, the battery voltage has not yet reached boost voltage, the controller

operates in constant current mode, delivering its maximum current to the batteries (MPPT Charging).

(2) Boost Charging

When the battery voltage reaches the boost voltage set point, the controller will start to operate in constant charging mode, this process is no longer MPPT charging, and in the meantime the charging current will drop gradually, the process is not the MPPT charging. The Boost stage maintain 2 hours in default. When the accumulate time reach to 2hours, the charging mode will turn to Float charging.

(3) Float Charging

After the boost voltage stage, the controller will reduce charging current to Float Voltage set point. This stage will have no more chemical reactions and all the charge current transforms into heat and gas at this time. Then the controller reduces the voltage to the floating stage, charging with a smaller voltage and current. It will reduce the temperature of the battery and prevent the gassing and charging the battery slightly at the same time. The purpose of Float stage is to offset the power consumption caused by self consumption and small loads in the whole system, while maintaining full battery storage capacity.

In Float charging stage, loads are able to obtain almost all power from solar panel. If loads exceed the power, the controller will no longer be able to maintain battery voltage in Float charging stage. If the battery voltage remains below the Recharge Voltage, the system will leave Float charging stage and return to Bulk charging stage.

1.4 Included accessories

No.	accessories	Instruction	Quantity	Picture
1	temperature sensor	the standard length of the cable is 1M. 2P-3.5mm	1 pc	



The above-included accessories are packed in a plastic bag and a box, Please check after opening the package.

The manufacturer may adjust the standard Bluetooth module without prior notice.



Do not insert the same model terminals into different interfaces. Otherwise, the controller will be damaged.

1.5 Optional accessory

WiFi Module CM-W01

After the controller is connected with the CM-W01 through the standard Ethernet cable (parallel cable), the operating status and related parameters of the controller can be monitored by the mobile iConnect App software through

WiFi signals.



NOTE: For setting and operation of accessory, please refer to accessory's user manual.

2 .Installation Instructions

2.1 General Installation Notes

- Please read the entire installation instructions to get familiar with the installation steps before installation.
- Be very careful when installing the batteries, especially flooded lead-acid battery. Please wear eye protection, and have fresh water available to wash and clean any contact with battery acid.
- Keep the battery away from any metal objects, which may cause short circuit of the battery.
- Explosive battery gases may come out from the battery during charging, so make sure ventilation condition is good.
- Ventilation is highly recommended if mounted in an enclosure. Never install the controller in a sealed enclosure with flooded batteries! Battery fumes from vented batteries will corrode and destroy the controller circuits.
- Loose power connections and corroded wires may result in high heat that can melt wire insulation, burn surrounding materials, or even cause fire. Ensure tight connections and use cable clamps to secure cables and prevent them from swaying in mobile applications.
- Lead-acid battery and lithium battery are recommended, other kinds please refer to the battery manufacturer.
- Battery connection may be wired to one battery or a bank of batteries. The following instructions refer to a singular battery, but it is implied that the battery

connection can be made to either one battery or a group of batteries in a battery bank.

- Multiple same models of controllers can be installed in parallel on the same battery bank to achieve higher charging current. Each controller must have its own solar module(s).
- When selecting connection wires for the system, follow the criterion that the current density is not larger than 5A/mm².

2.2 PV Array Requirements

(1) Serial connection (string) of PV modules

As the core component of PV system, controller could be suitable for various types of PV modules and maximize converting solar energy into electrical energy. According to the open circuit voltage (Voc) and the maximum power point voltage (VMpp) of the MPPT controller, the series number of different types PV modules can be calculated. The below table is for reference only.

Table 2-1 iTD2415/iTD2315

System voltage	36 cell Voc < 23V		48 cell Voc < 31V		54 cell Voc < 34V		60 cell Voc < 38V	
	Max.	Best	Max.	Best	Max.	Best	Max.	Best
12V	4	2	3	1	3	1	2	1
24V	6	3	4	2	4	2	3	2
48V	6	5	4	3	4	3	3	3

System voltage	72 cell Voc < 46V		96 cell Voc < 62V		Thin-Film Module Voc > 80V
	Max.	Best	Max.	Best	
12V	2	1	1	1	1
24V	3	2	2	1	1
48V	3	2	2	2	1

Table 2-2 iTD2612/iTD2412

System voltage	36 cell Voc < 23V		48 cell Voc < 31V		54 cell Voc < 34V		60 cell Voc < 38V	
	Max.	Best	Max.	Best	Max.	Best	Max.	Best
12V	5	2	3	1	3	1	2	1
24V	5	3	3	2	3	2	3	2

System voltage	72 cell Voc < 51V		96 cell Voc < 62V		Thin-Film Module Voc > 80V
	Max.	Best	Max.	Best	
12V	2	1	1	1	1
24V	2	1	1	1	1

NOTE: The above parameter values are calculated under standard test conditions (STC (Standard Test Condition): Irradiance 1000W/m², Module Temperature 25°C, Air Mass1.5.)

(2) Maximum PV array power

The MPPT controller has the function of current/power-limiting, that is, during the charging process, when the charging current or power exceeds the rated charging current or power, the controller will automatically limit the charging current or power to the rated charging current or power, which can effectively protect the charging parts of controller, and prevent damages to the controller due to the connection of some over-specification PV modules. The actual operation of PV array is as follows:

Condition 1:

Actual charging power of PV array ≤ Rated charging power of controller

Condition 2:

Actual charging current of PV array ≤ Rated charging current of controller

When the controller operates under "Condition 1" or "Condition 2", it will carry out the charging as per the actual current or power; at this time, the controller can work at the maximum power point of PV array.

⚠WARNING: When the power of PV is not greater than the rated charging power, but the maximum open-circuit voltage of PV array is more than the Max.solar input voltage of controller (at the lowest environmental temperature), the controller may be damaged.

Condition 3:

Actual charging power of PV array > Rated charging power of controller

Condition 4:

Actual charging current of PV array > Rated charging current of controller

When the controller operates under "Condition 3" or "Condition 4", it will carry out the charging as per the rated current or power.

⚠WARNING: When the power of PV module is greater than the rated charging power, and the maximum open-circuit voltage of PV array is more than the Max.solar input voltage of controller(at the lowest environmental temperature), the controller may be damaged.

Table 2-2 maximum power of PV array for this controller

Model	Rated Charge Current	Rated Charge Power	Max. PV open circuit voltage
iTD4315	30A	390W/12V 780W/24V 1560W/48V	138V(25℃) 150V(Lowest temperature)
iTD2412	45A	580W/12V 1170W/24V	110V(25℃) 120V(Lowest temperature)
iTD4415	40A	520W/12V 1040W/24V 2080W/48V	138V(25℃) 150V(Lowest temperature)
iTD2612	60A	800W/12V 1600W/24V	110V(25℃) 120V(Lowest temperature)

2.3 Wire Size

The wiring and installation methods must conform to all national and local electrical code requirements.

PV Wire Size

Since PV array output can vary due to the PV module size, connection method or sunlight angle, the minimum wire size can be calculated by the I_{sc} of PV array. Please refer to the value of I_{sc} in the PV module specification. When PV modules connect in series, the I_{sc} is equal to a PV modules I_{sc} . When PV modules connect in parallel, the I_{sc} is equal to the sum of the PV module's I_{sc} . The I_{sc} of the PV array must not exceed the controller's maximum PV input current. Please refer to the table as below:

NOTE: All PV modules in a given array are assumed to be identical.

* I_{sc} =short circuit current(amps) V_{oc} =open circuit voltage.

Table 2-3 PV array must not exceed the controller's maximum

Model	Max.battery wire size	Max. PV wire size *
iTD4315	16mm ² /6AWG	16mm ² /6AWG
iTD2412	16mm ² /6AWG	16mm ² /6AWG
iTD4415	25mm ² /4AWG	25mm ² /4AWG
iTD2612	25mm ² /4AWG	25mm ² /4AWG

* These are the maximum wire sizes that will fit the controller terminal



- ① The wire size is only for reference. Suppose a long-distance exists between the PV array and the controller or between the controller and the battery. In that case, larger wires shall be used to reduce the voltage drop and improve the system performance.
- ② The recommended wire for the battery that its terminals are not connected to any additional inverter.

2.4 Mounting

Warning: risk of explosion! Never install the controller and an open battery in the same enclosed space! Nor shall the controller be installed in an enclosed space where battery gas may accumulate.

Warning: danger of high voltage! Photovoltaic arrays may produce a very high open-circuit voltage. Open the breaker or fuse before wiring, and be very careful during the wiring process.

Note: when installing the controller, make sure that enough air flows through the controller's radiator, and leave at least 100mm of space both above and below the controller so as to ensure natural convection for heat dissipation. If the controller is installed in an enclosed box, make sure the box delivers reliable heat dissipation effect.



Figure 2-1 Mounting

2.5 Installation Procedure

Step 1: choose the installation site

Do not install the controller at a place that is subject to direct sunlight, high

temperature or water intrusion, and make sure the ambient environment is well ventilated.

Step 2: Place the controller at a proper position, Open the cover and use a screw driver to fit screws in mounting hole.

⚠️ CAUTION: If the controller is to be installed in an enclosed box, it is important to ensure reliable heat dissipation through the box.

Step 3: wire

Connect the system in the order of ①battery ② PV array in accordance with Figure 2-2, "Schematic Wiring Diagram". and disconnect the system in the reverse order ②①.

① Single controller



② Connection in parallel

Parallel Charging:

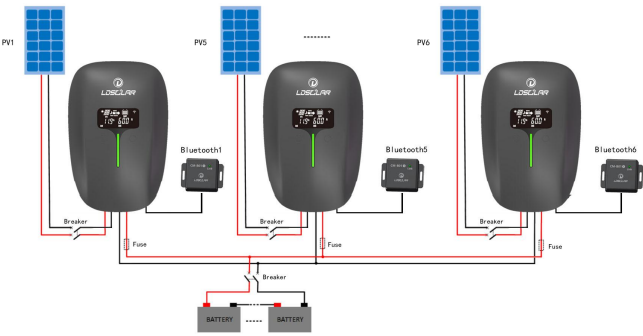

Figure 2-2 Schematic of wiring diagram

⚠️ CAUTION: While wiring the controller do not close the circuit breaker or fuse and make sure that the leads of "+" and "-" poles are connected correctly.

⚠️ CAUTION: A fuse which current is 1.25 to 2 times the rated current of the controller, must be installed on the battery side with a distance from the battery not greater than 150 mm.

⚠️ CAUTION: If an inverter is to be connected to the system, connect the inverter directly to the battery.

Step 4: Connect accessories

- ① Connect the remote temperature sensor cable to the interface and place the other end close to the battery
- ② Plug the external Bluetooth or WiFi module into the RJ45 interface and the indicator light on the module will be on.

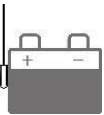

Step 5: Grounding

iTD series are common-negative controllers. Negative terminals of the PV array, the battery can be grounded simultaneously. However, according to the practical application, the PV array and battery's negative terminals can also be ungrounded.

For common-negative systems, such as the RV system, it is recommended to use a common-negative controller. If a common-positive controller is used and the positive electrode is grounded in the common-negative system, the controller may be damaged.

Step 6: Power on the controller

- ① After connecting all power wires solidly and reliably, check again whether wiring is correct and if the positive and negative poles are reversely connected. After confirming that no faults exist, firstly switch on breaker of the battery, then see whether the LED indicators light be on and the LED screen displays information. If the LED screen fails to display information, switch off the breaker immediately and recheck if all connections are correctly done.
- ② If the battery functions normally, then connect the solar panel or switch on the

breaker of solar panel. If sunlight is intense enough, the controller's charging indicator will light up or flash and begin to charge the battery.

Note:1) If no remote temperature sensor is connected to the controller, the battery temperature value will stay at 25 °C.



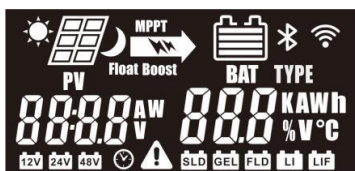

2) If an inverter is deployed in the system, directly connect the inverter to the battery.

3. Operation











3.1 Button

Mode	Note
Clear Fault	Press the “OPERATION” button()
Browsing Mode	Press the “MENU” button()
Setting Mode	Press the “MENU” button. and hold on 5s to enter the setting mode Press the “OPERATION” button. to set the parameters, Press the “MENU” button. to confirm the setting parameters or no operation for 10s, it will exit the setting interface automatically.
Work Record	On the main interface, press and hold "MENU" and "OPERATION" button to enter the work record page. Press and hold the "OPERATION" button to clear the corresponding data.

3.2 Interface

(1) Status Description











Item	Icon	Status
PV array		In daytime and PV connected correctly
		At night or no PV connect or reverse connect
		No Charging
		Charging In MPPT
		In Float Charging Mode
		In Boost Charging Mode
	PV	PV Voltage, Current and Power
Battery		Battery Capacity Indicating
	12V 24V 48V	Current System Voltage
	BAT	Battery Voltage and Current
	BAT TYPE	Battery Type
	SLD GEL FLD LI LIF	Battery type instruction
		Bluetooth or WiFi connection instruction

(2) LED Indicator

Color	Status	Explanation
Green (Change from orange to green according to battery capacity)	6 LED Slow Scroll	In Charging, and the charging current is less than 1 / 3 of the rated current
	6 LED Fast Scroll	In Charging, and the charging current is more than 1 / 3 of the rated current
	6LED Slow Flash	The battery is about to be fully charged and enters the constant voltage charging state, and the charging current is less than 5A
Blue	1LED Slow Flash	No charge, the controller is in standby
Red	6LED Fast Flash	Battery over voltage or PV over voltage
	1LED Slow Flash	Battery Low voltage or over temperature protection

Note: the LED screen has a sleep function to save power. When it is detected that the solar panel cannot be charged, the controller will dim the brightness of the display after a delay of 5 minutes. Press any key or Restart charging can wake up the LED screen again.

(3) Fault Indication

Status	Icon	Description
Battery over discharged	 	Battery level shows empty, battery frame blink, fault icon blink
Battery over voltage	 	Battery level shows full, battery frame blink, fault icon blink
Controller over temperature	 	Temp.icon shows Temp.inside controller is higher than 75°C, temperature icon blink, fault icon blink
PV over voltage	 	It shows PV voltage is higher than rated PV open voltage. PV icon blink, fault icon blink
Bluetooth/WIFI unconnected	 	Bluetooth/WIFI Icon Flash

(2) Error Code Table

Status	Error Codes	Description
	E00	Normal
	E01	Battery Low Voltage Alarm
	E02	Battery Over Voltage Alarm
	E03	PV Over Voltage Alarm
	E04	Controller Internal Over Temperature

(3) Browse interface

① If there is no operation within 20s or after powered on within 10s in any interface. The main interface will cycle to display the PV and battery voltage, PV and battery current, PV power and battery temperature every 3s. Long press the "OPERATION" button () can speed up the cycle display time.

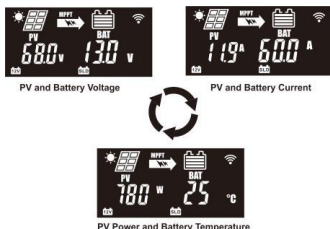

② At main interface (cycle display), long press "MENU" and "OPERATION" for more than 5S at same time to enter working record status, it can show today total power generation, total power generation, total charging amper hours, controller temperature, working days, times of low voltage, times of full charging and system setting. Press and hold the operation button on the corresponding interface can clear the data

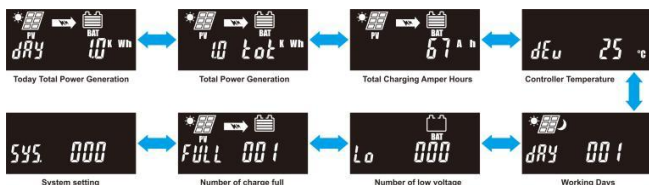

On the system setting page, press and hold "MENU" for 5S to enter the system setting state. Press Menu to change parameter display to "RST". Press and hold the MENU for 5S to save the setting, then the controller will reset and restart itself

③ At main interface (cycle display), Press the "MENU" button () and enter menu interface.

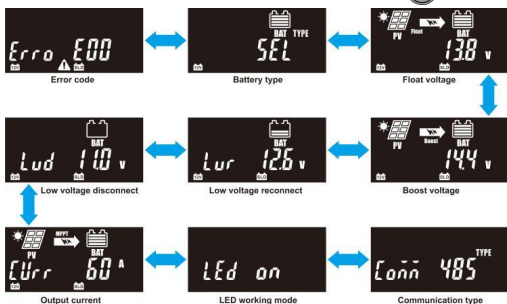

3.3 Setting

(1) Battery type

① Support battery types

Lead-acid battery	Sealed(default)
	Gel
	Flooded
	User
Lithium battery	LiFePO4(LF4/12V;LF8/24V;LF16/48V)
	Li(NiCoMn)O2 (LI3/12V;LI6/24V;LI7/24V;LI14/48V)

② Setting the battery type via LED

Step 1: At main interface(cycle display), Press the “MENU” button to enter battery type mode interface.

Step 2: Long press the “MENU” button($\geq 5S$) until the “SEL” is flashing, then it enters the setting state.

Step 3: Press the “MENU” and “OPERATION” button to confirm the battery type below:



Step 4: Long press the “MENU” button($\geq 5S$) to save the new setting. If there is no operation within 20S, the controller will enter the main interface and cycle to display automatically.

(2) Float Voltage Setting

Operation:

Step 1: At main interface(cycle display), Press “MENU” button to enter float voltage interface

Step 2: Long press the “MENU” button($\geq 5S$) until the value is flashing, then it enters the setting state.

Step 3: Press the “MENU” and “OPERATION” button to change the value

Step 4: After setting, Long press the “MENU” button($\geq 5S$) to save the new setting. If there is no operation within 20S, the controller will enter the main interface and cycle to display automatically.



(3) Setting of boost voltage, low voltage reconnect voltage and low voltage disconnect voltage

Operation: At main interface(cycle display), Press the “MENU” button to enter the relevant interface below:

The operation method of setting is the same as float voltage setting, Please refer to the above “2”

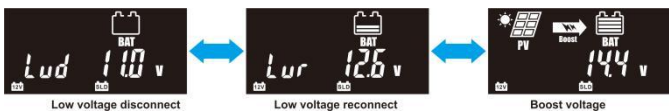

■ The following rules must be observed when modifying the parameter values in User

I. Charging Limit Voltage > Boost Charging Voltage > Float Charging Voltage > Boost Reconnect Charging Voltage.

II. Low Voltage Reconnect Voltage > Low Voltage Disconnect Voltage(BMS+0.2V)

III. Boost Reconnect Charging voltage > Low Voltage Reconnect Voltage > Low Voltage Disconnect Voltage(BMS+0.2V)

■ Battery Voltage Control Parameters

Below parameters are in 12V system at 25 °C, please double the values in 24V system and quadruple the values in 48V system

Battery Type	SEL 24V*2;48V*4	GEL 24V*2;48V*4	FLD 24V*2;48V*4	LiFePO4 LF4(4S/12V) LF8 (8S/24V*2) LFG (16S/48V*4)	Li(NiCoMn)O2 LI3 (3S/12V) LI6 (6S/24V*2)	Li(NiCoMn)O2 LI7(7S/24V) LIE (14S/48V*2)
Over Voltage Disconnect	16.0V	16.0 V	16.0 V	16.0V	17.0 V	32.0V
Charging Limited Voltage	15.0 V	15.0 V	15.0 V	14.8V	17.0 V	30.0V
Over Voltage Reconnect	15.0 V	15.0 V	15.0 V	14.8V	17.0 V	30.0V
Boost charge	14.4 V	14.2 V	14.6 V	14.6V	12.6V	29.4V
Float charge	13.8 V	13.8 V	13.8 V	14.4V	12.4V	29.0V
Boost Restart Voltage	12.6V	12.6V	12.6V	13.0V	11.5V	26.0V
Low voltage reconnect	12.6V	12.6V	12.6V	12.6V	11.0V	25.2V
Low voltage disconnect	11.0V	11.0V	11.0V	10.5V	9.0V	21.0V

(4) Charging Current Setting

Step 1: At main interface(cycle display),Press "MENU" button to enter charging current interface

Step 2: Long press the "MENU" button($\geq 5S$) until the value is flashing,then it enters the setting state.

Step 3: Press the "MENU"and "OPERATION" button to change the value,5A at a time

Step 4: After setting,Long press the"MENU"button($\geq 5S$) to save the new setting.If there is no operation within 20S,the controller will enter the main interface and cycle to display automatically.

Note:When connecting to a high-power solar panel, choosing a right current that matches the battery capacity can extend the battery life. The maximum charging current of lead-acid batteries should not exceed 1/5 of their capacity. For lithium batteries, refer to the recommended current provided by the manufacturer.



Output current

(5)LED Working Mode Setting

The setting method is the same as the above (4). The default is "ON". When setting to "ON", the LED indicates normally. When setting to "OFF", the LED does not light up. When setting to "Ato", the LED indicates a normal state when the PV can charge normally, and LED does not light up when the PV voltage is low (at night).



(6)Communication Indication Setting

The system defaults to "BLE" bluetooth, if the bluetooth device is connected and there is data transmission, the bluetooth icon is normally indicated. If there is no Bluetooth module for data connection, the Bluetooth icon will blink. When it is set to "WIF" (WiFi), if the WiFi device is connected and there is data transmission, the WiFi icon will indicate normally, if there is no WIFI module for data connection, the wifi icon will flash. When it is set to "485" communication, the main interface does not display the corresponding icon. The setting method is the same as above (4).

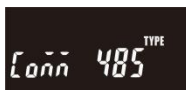

4. Protections, Troubleshooting and Maintenance





4.1 Protection

PV current/power limiting protection	When the charging current or power of the PV array exceeds the controller's rated current or power, it will be charged at the rated current or power. NOTE: When the PV modules are in series, ensure that the open-circuit voltage of the PV array does not exceed the "maximum PV open-circuit voltage" rating. Otherwise the controller may be damaged.
PV Short Circuit	When not in PV charging state, the controller will not be damaged in case of a short-circuiting in the PV array.
PV Reverse Polarity	When the polarity of the PV array is reversed, the controller may not be damaged and can continue to operate normally after the polarity is corrected.
Night Reverse Charging	Prevents the battery from discharging through the PV module at night.
Battery Reverse Polarity	Fully protected against battery reverse polarity; no damage will occur for the battery. Correct the wrong wiring to resume normal operation. NOTE: Limited to the characteristic of lithium battery, when the PV connection is correct and battery connection reversed, the controller will be damaged.
Night reverse	Prevent the battery from discharging to the PV module at

charging protection	night.
Battery Over Voltage	When the battery voltage reaches the over voltage disconnect voltage, it will automatically stop battery charging to prevent battery damage caused by over-charging.
Battery Over Discharge	When the battery voltage reaches the low voltage disconnect voltage, it will automatically stop battery discharging to prevent battery damage caused by over-discharging. (Any controller connected loads will be disconnected. Loads directly connected to the battery will not be affected and may continue to discharge the battery.)
Controller Overheating	The controller is able to detect the temperature inside the battery. The controller stops working when its temperature exceeds 85 °C and restart to work when its temperature is below 65 °C.
TVS High Voltage Transients	The internal circuitry of the controller is designed with Transient Voltage Suppressors (TVS) which can only protect against high-voltage surge pulses with less energy. If the controller is to be used in an area with frequent lightning strikes, it is recommended to install an external surge arrester.

★When the internal temperature is 75°C, the reducing power charging mode which reduce the charging power of 5% every increase 1 °C is turned on. If the internal temperature is greater than 85°C, the controller will stop charging. When the temperature declines to be below 65 °C, the controller will resume.

4.2 Troubleshooting

Possible reasons	Faults	Troubleshooting
PV array disconnection	LED display during daytime 	Confirm that PV wire connections are correct and tight.
Battery voltage is lower than 8V	Wire connection is correct, the controller is not working.	Please check the voltage of battery. At least 8V voltage to activate the controller.
Battery over voltage	  Battery level shows full, battery frame blink, fault icon blink	Check if battery voltage is higher than OVD(over voltage disconnect voltage), and disconnect the PV.
Battery over discharged	  Battery level shows empty ,battery frame n blink	When the battery voltage is restored to or above LVR(low voltage reconnect voltage), the load will recover

4.3 Maintenance

The following inspections and maintenance tasks are recommended at least two times per year for best performance.

- Make sure controller firmly installed in a clean and dry ambient.
- Make sure no block on air-flow around the controller. Clear up any dirt and fragments on radiator.
- Check all the naked wires to make sure insulation is not damaged for solarization, frictional wear, dryness, insects or rats etc. Repair or replace some wires if necessary.
- Tighten all the terminals. Inspect for loose, broken, or burnt wire connections.
- Check and confirm that LED is consistent with required. Pay attention to any troubleshooting or error indication .Take corrective action if necessary.
- Confirm that all the system components are ground connected tightly and correctly.
- Confirm that all the terminals have no corrosion, insulation damaged, high temperature or burnt/discolored sign, tighten terminal screws to the suggested torque.
- Check for dirt, nesting insects and corrosion. If so, clear up in time.
- Check and confirm that lightning arrester is in good condition. Replace a new one in time to avoid damaging of the controller and even other equipments.



WARNING: Risk of electric shock!

Make sure that all the power is turned off before above operations, and then follow the corresponding inspections and operations.

5. Technical Specifications

5.1 Electrical Parameters

Item	iTD2412	iTD2612	iTD4315	iTD4415
System nominal voltage	12/24VDC	Auto ①	12/24/48VDC	Auto ①
Rated charge current	45A	60A	30A	40A
Battery voltage range	8 ~ 32V		8 ~ 68V	
Max. PV open circuit voltage	② 120V ③ 110V		② 150V ③ 138V	
MPP voltage range	(Battery voltage +2V) ~ 85V		(Battery voltage +2V) ~ 108V	
Rated charge power	580W/12V 1170W/24V	800W/12V 1600W/24V	390W/12V 780W/24V 1560W/48V	520W/12V 1040W/24V 2080W/48V

Self-consumption	≤50mA(12V)/35mA(24V)/24mA(48V)
LVD	11.0V ADJ 9V....12V; ×2/24V; ×4/48V
LVR	12.6V ADJ 11V....13.5V; ×2/24V; ×4/48V
Float voltage	13.8V ADJ 13V....15V; ×2/24V; ; ×4/48V
Boost voltage	14.4V ; ×2/24; ×4/48V Battery Voltage less than Boost Restart Voltage Start Boost charging for 2hours
MPPT tracking efficiency	≥99.5%
Max. Conversion efficiency	98%
Grounding	Common negative
Battery Type	Sealed(Default)/Gel/Flooded/LiFePO4/ Li(NiCoMn)O2/ User
Temperature compensate Coefficient ④	-4mv/°C/2V
Communication method	RS485(5VDC/200mA)

①When a lithium battery is used, the system voltage can't be identified automatically.

②At minimum operating environment temperature

③At 25°C environment temperature

④When a lithium battery is used, the temperature compensate coefficient will be 0.

5.2 Environmental Parameters

Working environment temperature◆	-20°C ~ +50°C(100% input and output)
Storage temperature range	-20°C ~ +70°C
Relative humidity	≤95%, N.C.
Enclosure	IP30

◆The controller can work under full load in the working environment temperature, When the internal temperature is more than 80°C, the reducing power charging mode is turned on.

5.3 Mechanical Parameters

Item	iTD2412	iTD4315	iTD2612	iTD4415
Dimension(L*W*H)	258×170×97mm		288×190×108mm	
Mounting Dimension(A*B)	120×120mm		138×140mm	
Mounting hole size	Φ5mm		Φ6mm	
Weight	1.8KGS	1.7KGS	2.4KGS	2.2KGS

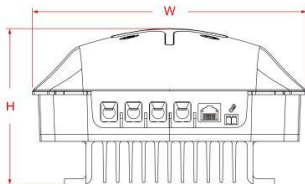
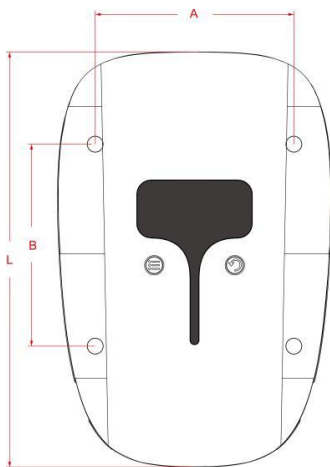

Any changes without prior notice

Version:iTD V1.4



LD SOLAR

Your battery guard