



深圳市联佑光电技术有限公司

SHENZHEN LEARNOW OPTOELECTRONICS TECHNOLOGY CO.,LTD.
TEL:0755-29084995 FAX:0755-23224565 WEB:www.learnow-led.com

Datasheet

UV LED Lamp Curing System

Model: LN-CP-300



深圳市联佑光电技术有限公司

SHENZHEN LEARNEW OPTOELECTRONICS TECHNOLOGY CO.,LTD.
TEL:0755-29084995 FAX:0755-23224565 WEB:www.learnnew-led.com

一、主机规格 Main Machine Specification

- ❖ 驱动器名字 Driver Name 600W LED Driver
- ❖ 驱动器型号 Driver Model DRV600W
- ❖ 结构尺寸 Size 330mm(L)*174mm(W)*260(H)mm
- ❖ 冷却方式 Cooled Method 风冷 Air Cooled
- ❖ 电压输入 Voltage Input 220V
- ❖ 最大输出功率 Max Power Output 600W
- ❖ 信号端口电压 Signal Port Voltage 0~12v
- ❖ 功率调整范围 Power adjustment 10~100%
- ❖ 重量 Weight <30kg

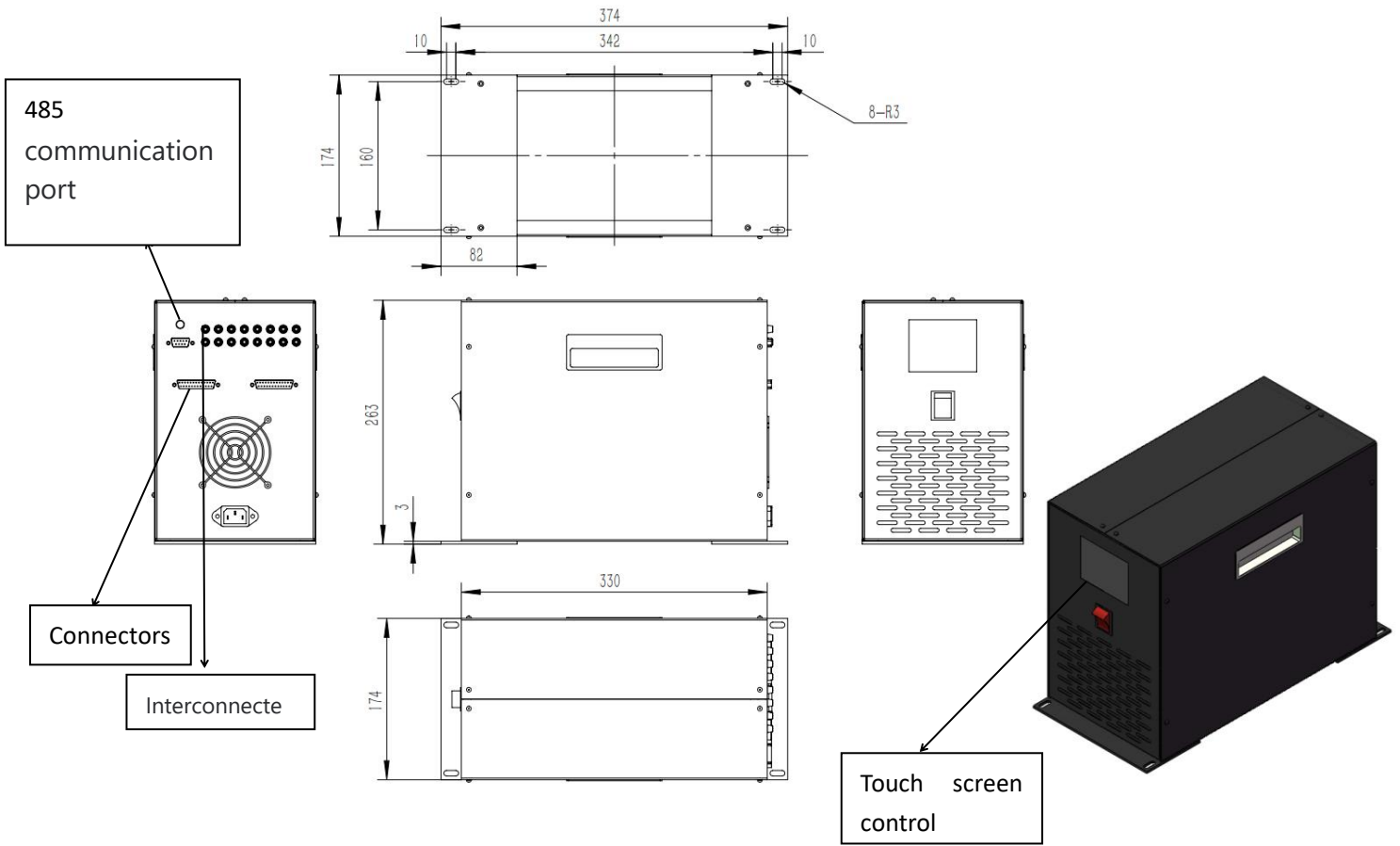



深圳市联佑光电技术有限公司

SHENZHEN LEARNOW OPTOELECTRONICS TECHNOLOGY CO.,LTD.
TEL:0755-29084995 FAX:0755-23224565 WEB:www.learnow-led.com

二、UVLED 固化灯规格 UV Lamp specification

- ❖ 产品名称 Model name LN-CP-300
- ❖ 波长 Wavelength coverage 395NM
- ❖ 有效照射强度 Irradiance >10w/cm²
- ❖ 有效照射面积 Effective radiation area 150mm*20mm
- ❖ 建议照射高度 Radiation distance 3-10mm
- ❖ 冷却方式 Cooling method 水冷 water cooled
- ❖ 照射头尺寸 Dimension 2 160mm(L)*48mm(W)*68mm(H)
- ❖ 重量 Weight <2kg
- ❖ 驱动方式 Power input 恒流电源 constant current source
- ❖ 控制方式 Control Method 开关信号，高低电平
- ❖ 功耗 Power consumption 0-600W

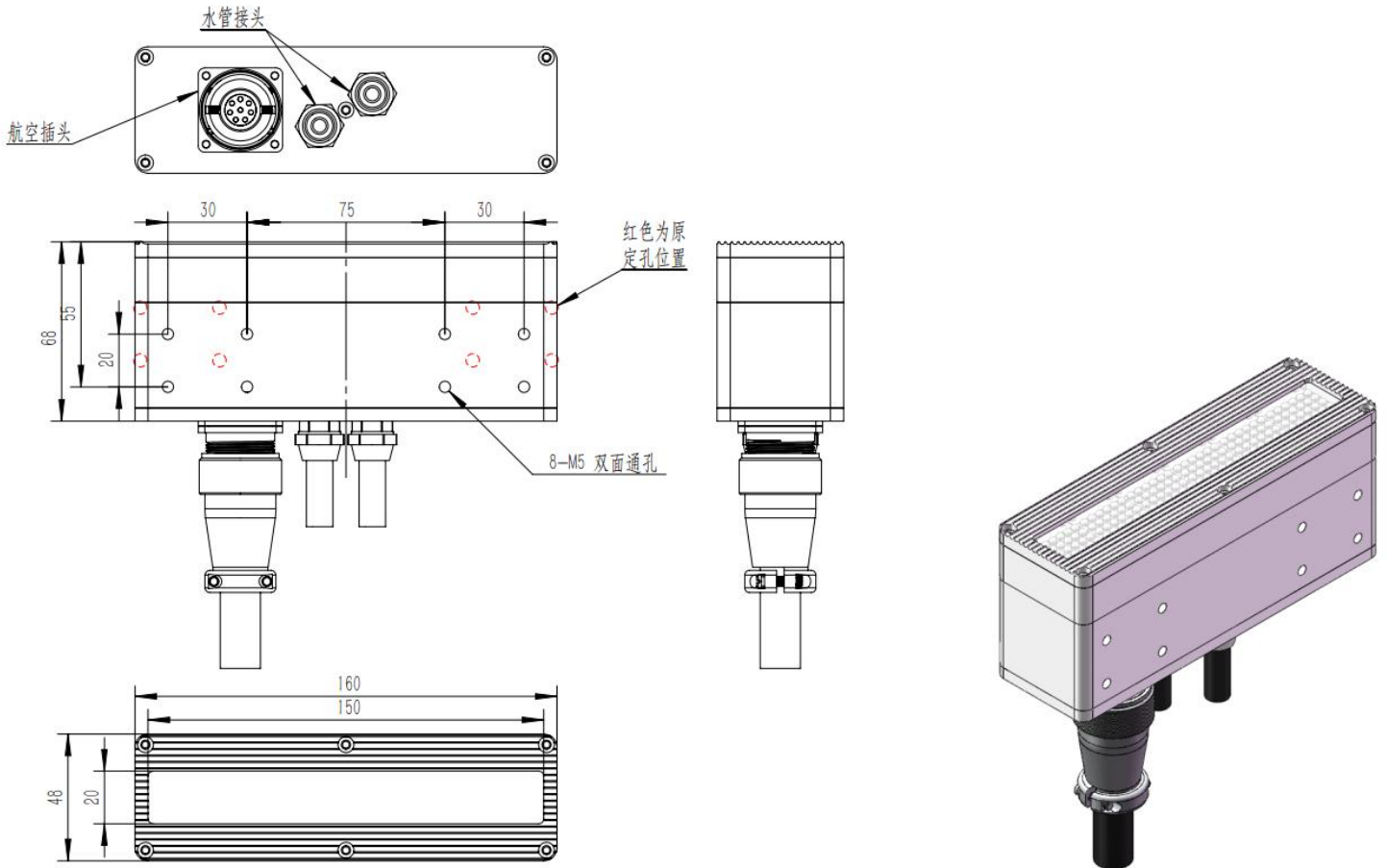



深圳市联佑光电技术有限公司

SHENZHEN LEARNEW OPTOELECTRONICS TECHNOLOGY CO.,LTD.
TEL:0755-29084995 FAX:0755-23224565 WEB:www.learnew-led.com

三、水冷机规格 Chiller specification

- ❖ 工作电压 Voltage 220V
- ❖ 压缩机功率 Compressor power 0.295KW
- ❖ 制冷量 Refrigeration capacity 0.8KW
- ❖ 水泵功率 Pump power 0.03KW
- ❖ 最大扬程 Max lift 25M
- ❖ 最大流量 Max flow 16L/MIN



<p>节流器 Reducer</p>  <p>毛细管 Capillary</p>	<p>温控精度 Precision</p>  <p>±0.3°C</p>	<p>制冷剂 Refrigerant</p> <p>R-22/410a</p> 	<p>水箱容量 Tank capacity</p>  <p>6 L</p>
<p>安全保护 Protection</p>  <p>压缩机过流保护 Overcurrent protection for compressor</p> <p>流量报警 Flow alarm</p> <p>超温报警 Over temperature alarm</p>	<p>重量 Weight</p> <p>净重 N.W. 26Kgs</p> <p>毛重 G.W. 29Kgs</p>	<p>机器尺寸 Product dimension</p> <p>58 X 29 X 47 cm (L X W X H)</p> 	<p>包装尺寸 Package dimension</p> <p>70 X 43 X 58 cm (L X W X H)</p> 



深圳市联佑光电技术有限公司

SHENZHEN LEARNFW OPTOELECTRONICS TECHNOLOGY CO.,LTD.
TEL:0755 20024005 FAX:0755 23274565 WEB:www.learnfw-led.com

四、产品服务 Products & Services

深圳市联佑光电技术有限公司致力于研发、生产、销售、服务为一体的光电科技企业。公司有强大的研发团队，生产及研发光电模块，是全国首屈一指的 UVLED 固化设备生产商。我们的服务宗旨是对于客户反应迅速，对客户是我们服务的唯一标准。

1. UV 设备操作使用说明 UV equipment operation instructions

2. UV 设备的保养及维护 UV equipment maintenance and maintenance

3. 公司对于客户反应迅速，基于对客户是我们服务的唯一标准

quick to respond to customers, based on the customer is the only standard of our service

4. 可以为客户量身定做光头，机器，按客户产品的需求提供及时的回应

customized for the customer head, machine, according to the needs of customer products to provide timely response

5. 光源可以有效的使用>20000h，一年内包换保修（非人为损坏）

Light source can be effectively used >20000h, one year warranty (non-human damage)