

# ALL-IN-ONE Solar Street Light

60W/90W/120W/150W

Our all-in-one solar street light is super bright and ultra-wide, irradiation and the street light covers up to 120°, which can easily illuminate a 400 square foot area. It's built-in large-capacity battery, additional battery can increase energy by 66%, making the life of street lights longer. In the daytime, it can be fully charged in 6-8 hours and provides you with 30-36 hours of night lighting to provide bright lighting to ensure your way safety.



## PRODUCT OVERVIEW

### ► Cope Harsh Weather, IP65 Waterproof

This solar street light has very good waterproof, rainproof and lightning-proof performance, -4° F~120°F temperature resistance, IP65 waterproof, can work in all kinds of bad weather.

### ► High Brightness Solar Light

Our solar street light features 160 lm/w output lumens, which could provide super bright light meet your demand. It uses high quality SMD3030 LED chips to give you the best illumination experience but won't consume too much energy.

### ► Secondary optical design

The secondary optical design makes the light emitted by the LED light source illuminate the illuminated area through the secondary focusing, so that the light can be effectively used.

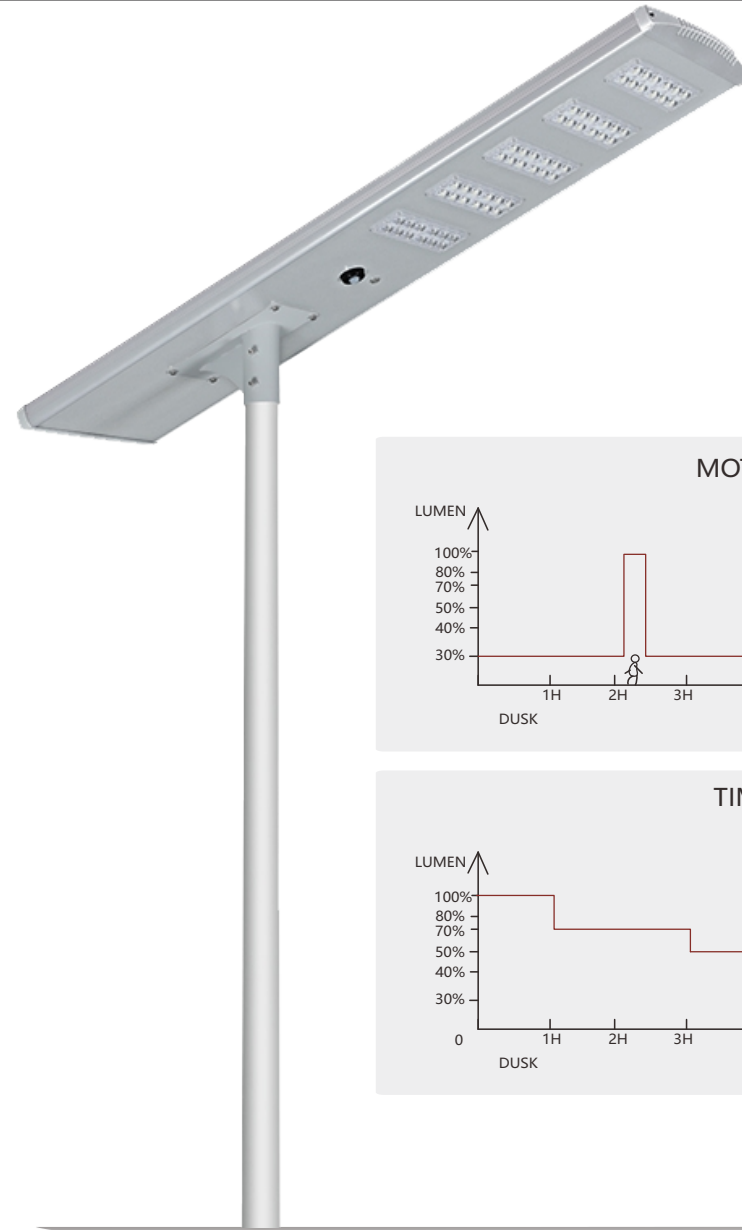

## HOW THE LIGHT WORKS

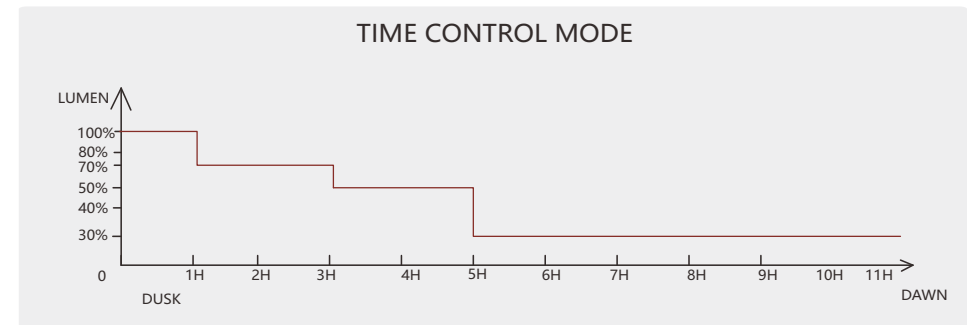
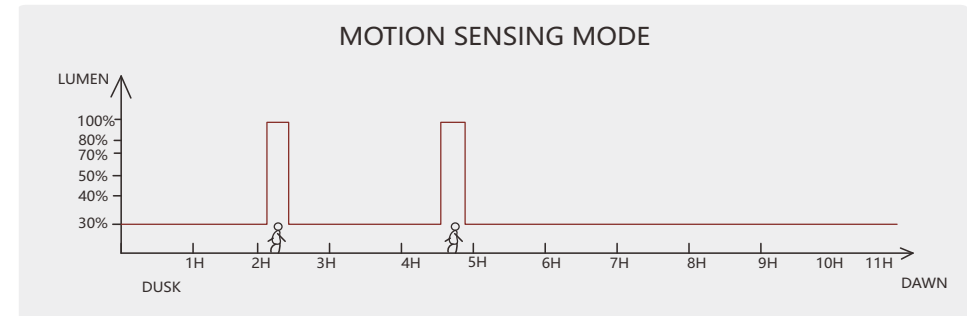

## PRODUCT DETAILS

### Anti-UV Optical lens

The Lens makes the light spot is uniform, there is no astigmatism, no shadow, and the transmittance is very high, which maximizes the utilization of LED light.

### Motion Sensor

The light will work automatically at night. When people come, the light will working at 100% power, after people gone, the light will working at 30% power.

### Aluminum Alloy Lamp Housing

The lamp housing is made of aluminum alloy, anodizing treatment on surface, and no fade. which is strong and stable, waterproof and rust-proof.

### Solar Panel

High quality polycrystalline silicon material, high charging efficiency, long lifespan



Built-in LED chip, enable solar street lights to emit high brightness with low heat even after long time usage.

### LED Chip



### LX-DISTANCE DIAGRAM

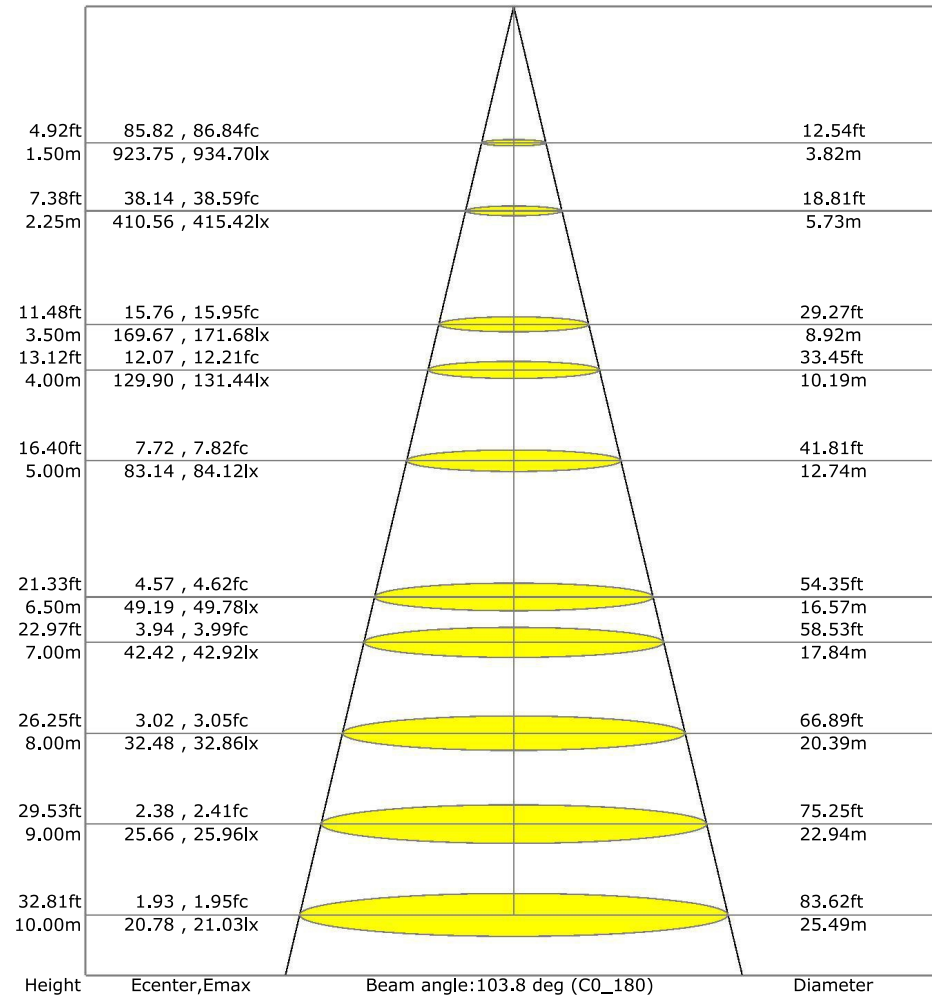

### LUMINAIRE BUDGETARY ESTIMATE DIAGRAM

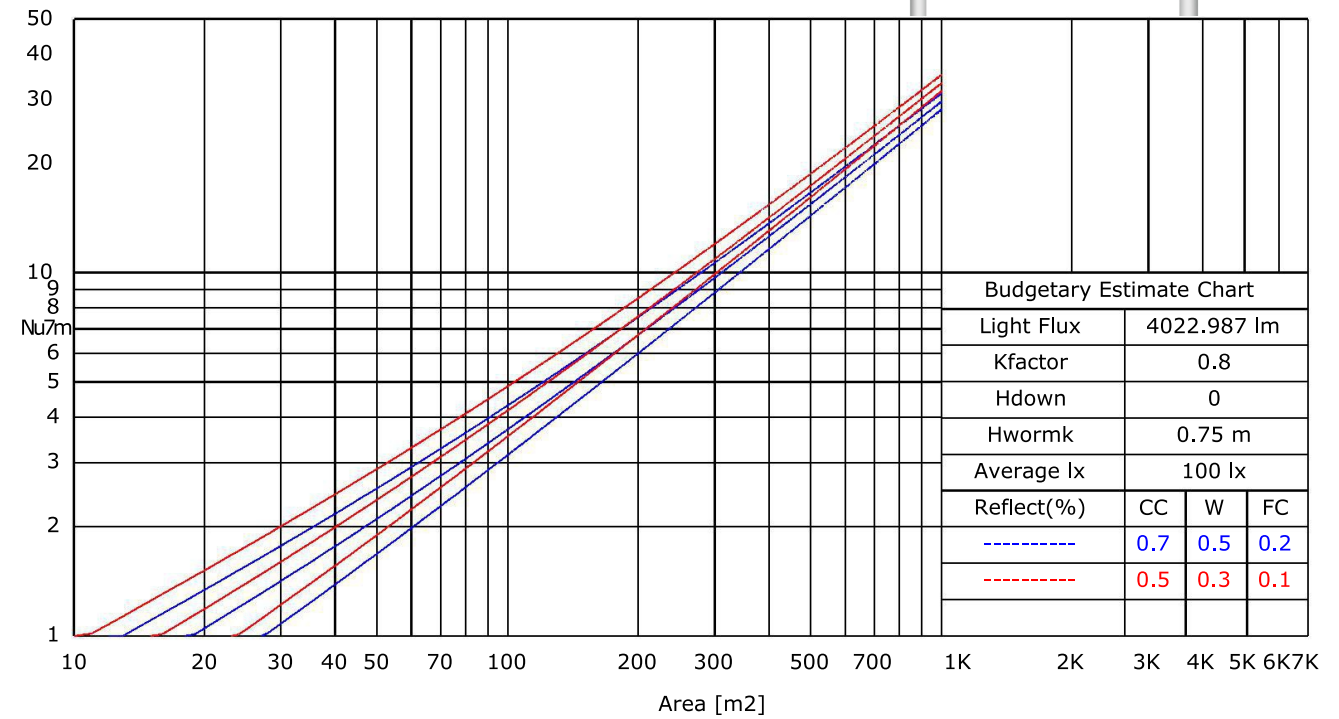

### 150W DIALUX SIMULATION EFFECT

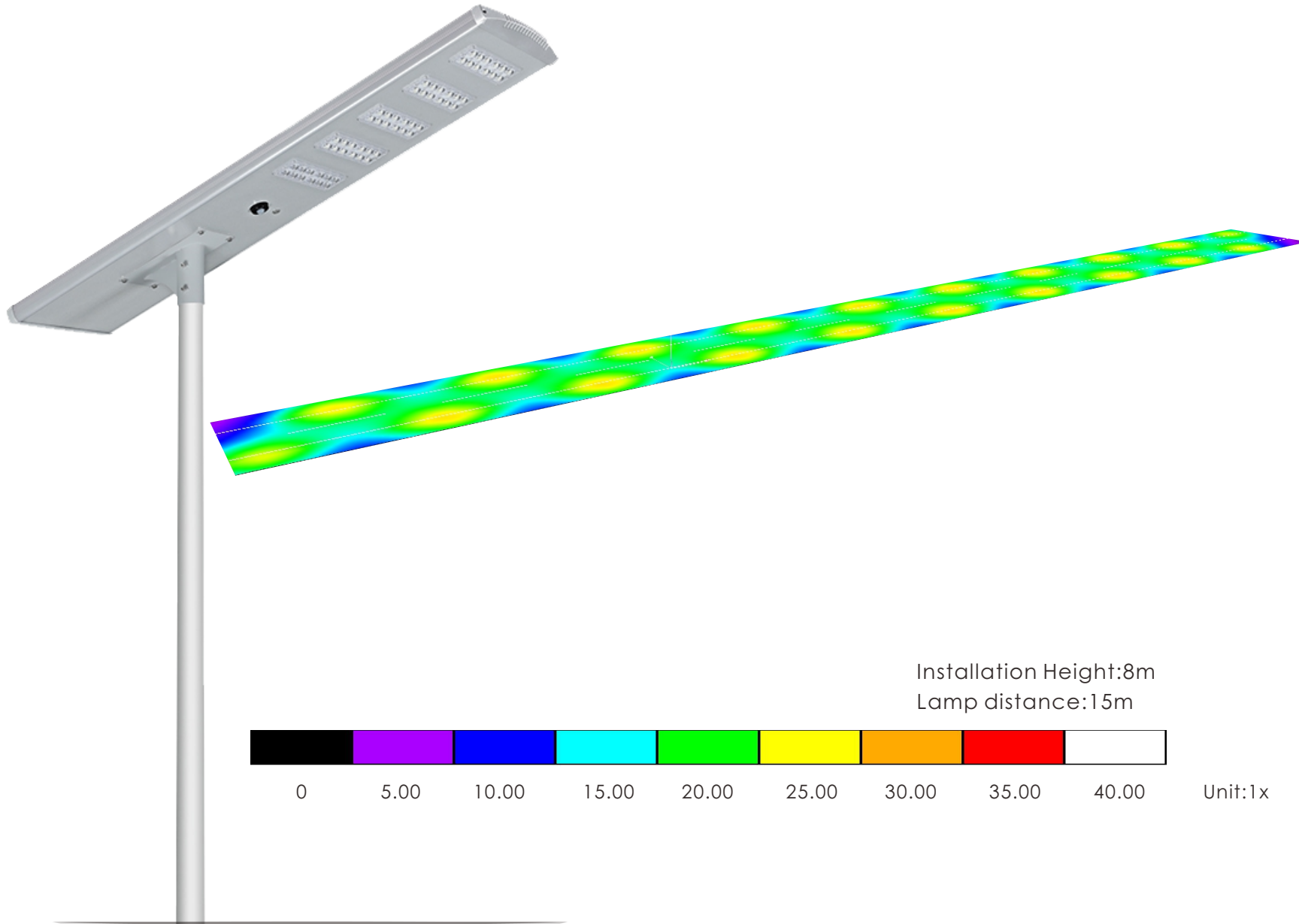

### LUMINOUS INTENSITY DISTRIBUTION CURVE

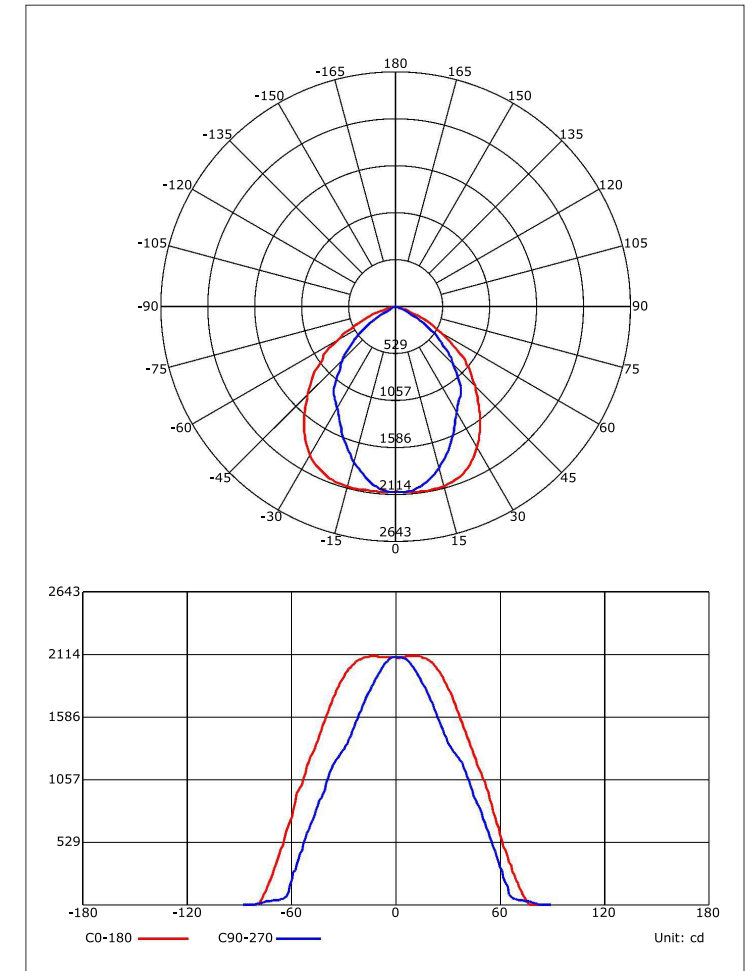

## BATTERY SPECIFICATION

DesignLife	6-8 years			
Nominal Voltage	3.2V			
Nominal Capacity	43AH	86AH	86AH	129AH
Self-Discharge				
3% of capacity declined per month at 20°C(average)				
Operation Temperature Range				
Discharge	-20~60°C			
Charge	-10~60°C			
Storage	-20~60°C			
Max.Discharge Current 77°F(25°C)	50A(5s)			
Short Circuit Current	100A			

## BATTERY GUARANTEE OF QUALITY

### Battery Cells

High-end battery cells keep every cell's voltage, resistance, capacity, discharging always in sync.

### Battery Protector

High precision IC keep performance more stable protect over load, over charge, over discharge, short circuit, over voltage, over current keep battery pack always safe and long life span.



### Precision Welding Machine

Fully automatic precision welding machine can ensure that every battery can be welded firmly to prevent the danger of short circuit or power failure.

### Aging Test Machine

every battery pack need to thorough charging and discharging test by the aging test machine to keep 100% qualified.

## SMD 3030 INTRODUCTION



The SMD 3030 offers exceptional performance in a compact LED package. This high power LED is hot-color targeted which ensures that the LEDs fall within their specified color bin at the typical application conditions of 85°C. With its broad lumen coverage and wide range of CCT and CRI options, the SMD 3030 provides unparalleled design-in flexibility for indoor and outdoor lighting applications. Its high flux capability reduces the number of LEDs and enables industry leading system level lumen per dollar. The SMD 3030 is ideal as a drop in replacement for emitters with an industry standard 3.0mm x 3.0mm footprint.

### Features

- Industry-standard 3030 footprint
- 9 bin color control enables tight color control
- Hot-color targeting ensures that color is within the ANSI bin at the typical application conditions of 85°C
- Enables 3- and 5-step MacAdam ellipse custom binning kits
- RoHS compliant and lead free
- Multiple CCT configurations for a wide range of lighting applications

### Benefits

- Lower operating and manufacturing cost
- Ease of design and rapid go-to-market
- Uniform consistent white light
- Reliable and constant white point
- Environmentally friendly, complies with standards
- Design flexibility



### Typical Color Spectrum

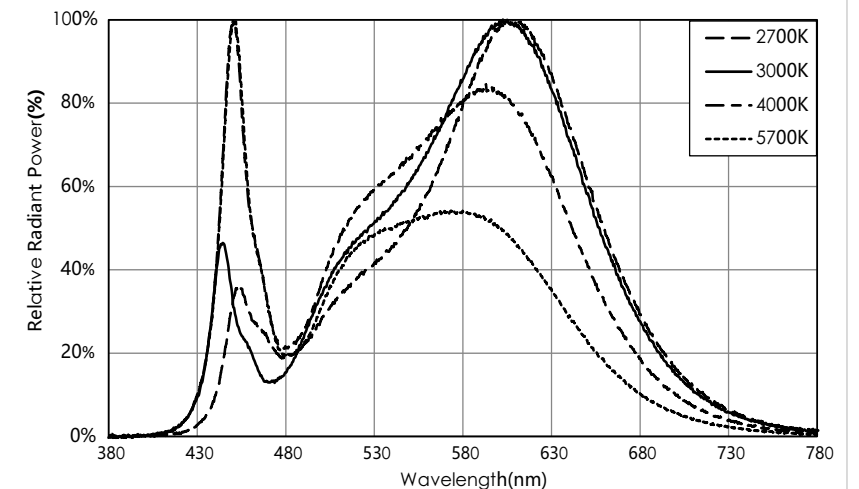

Note: Color spectra measured at nominal current for T<sub>sp</sub> = 25°C

## SOLAR PANEL SPECIFICATION

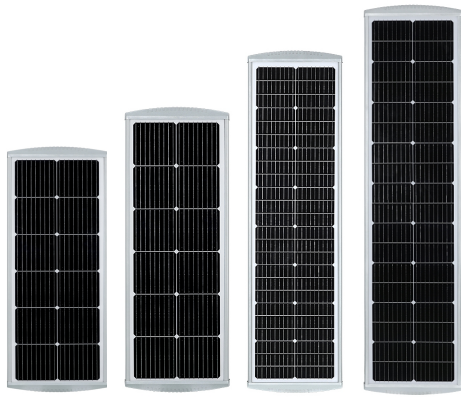

### Specifications

Peak Power(Pmax)	60/80/100/120
Maximum Power Voltage(Vmp)	6/6/6/6
Maximum Power Current(Imp)	10/13.33/16.66/20
Open Circuit Voltage(Voc)	10.1/10.1/10.1/10.1
Short Circuit Current(Isc)	7.1
Cells Efficiency(°C)	18.09
Module Efficiency(°C)	13.93
Power Tolerance	0~+3%
Pmax Temperature Coefficients(W/°C)	-0.400%
Voc Temperature Coefficients(V/°C)	-0.300%
Isc Temperature Coefficients(A/°C)	+0.060%
NOCT Nominal Operating Cell Temperature(°C)	45±2
Operating and Storage Temperature(°C)	-40~+85
Standard Test Condition(STC)	1.000W/m <sup>2</sup> ;AM 1.5;25+/-2°C

### Mechanical characteristics

Dimension	730*373*4.5mm
	1046*373*4.5mm
	1415*373*4.5mm
	1570*373*4.5mm
Front Glass	3.2mm high transmission,low iron,tempered glass
Junction box	IP65 Rated

### Product Standard

Product Performance	IEC61215
Product Safety	IEC61730

### Linear Performance Warranty

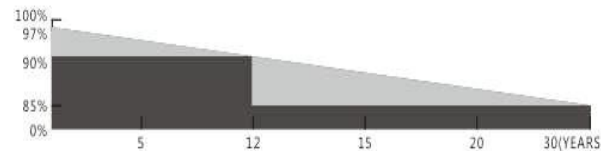

**12**  
YEARS

Guarantee on product material and workmanship

**30**  
YEARS

Linear Power output warranty

### Key Features



#### 5 Busbar Cell:

5 Busbar Solar cell adopts new technology to improve the efficiency of modules, offers a better aesthetic appearance making it perfect for rooftop installation and application



#### High Efficiency

High Module conversion efficiency, through innovative manufacturing technology



#### Low-Light Performance

Advanced glass and solar cell surface texturing allow for excellent performance in low-light environments

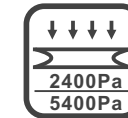

#### Serve Weather Resilience

Certified to withstand wind load(2400Pa) and snow load (5400Pa)



#### Durability against extreme environmental conditions

High salt mist and ammonia resistance certified by TUV



#### 0-+5W Positive Tolerance

Detailed information in Electrical Specifications



### PRODUCT SPECIFICATION

Model	0418A60-03	Product Size
LED Chip	3030LED 48PCS	
Luminous Efficiency	160lm/w	
Color Temperature	6000K	
Solar Panel	6V 60W, Mono-crystalline	
Battery Type	LiFePO4 3.2V 43AH	
Charging Time	6-8 hours	
Discharging Time	30-36 hours	
Control Way	Motion Sensor+Light Control	
Material	Aluminum alloy	
Product Size	811*407*209mm	
Install Height	3-5m	
Warranty	3 Years	

### PACKAGING SPECIFICATION

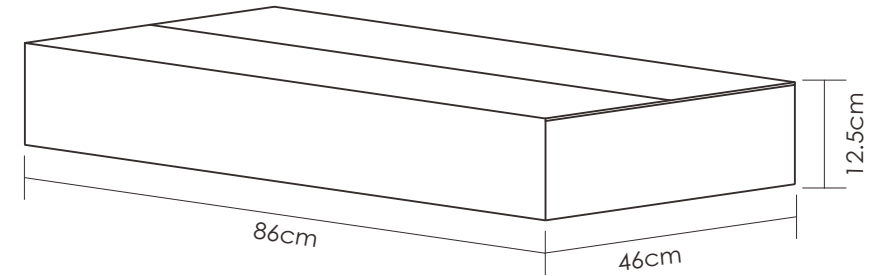

Lamp body

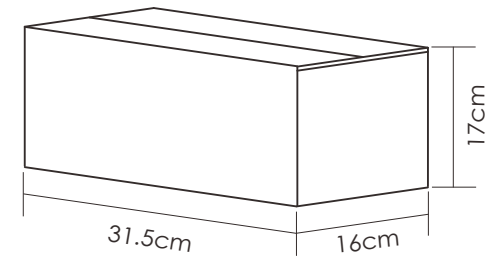

Support frame

P/N	Power	Packing Size(CM)			PCS/CTN	CBM/CTN	G.W/CTN (KGS)	
		L	W	H				
0418A60-03	60W	86.00	46.00	12.50	1	0.0495	11.2	Lamp body
		31.50	16.00	17.00	1	0.0086	1.6	Support frame

### PRODUCT SPECIFICATION

Model	0418B90-03	Product Size
LED Chip	3030LED 72PCS	
Luminous Efficiency	160lm/w	
Color Temperature	6000K	
Solar Panel	6V 80W, Mono-crystalline	
Battery Type	LiFePO4 3.2V 86AH	
Charging Time	6-8 hours	
Discharging Time	30-36 hours	
Control Way	Motion Sensor+Light Control	
Material	Aluminum alloy	
Product Size	1127*407*209mm	
Install Height	4-6m	
Warranty	3 Years	

### PACKAGING SPECIFICATION

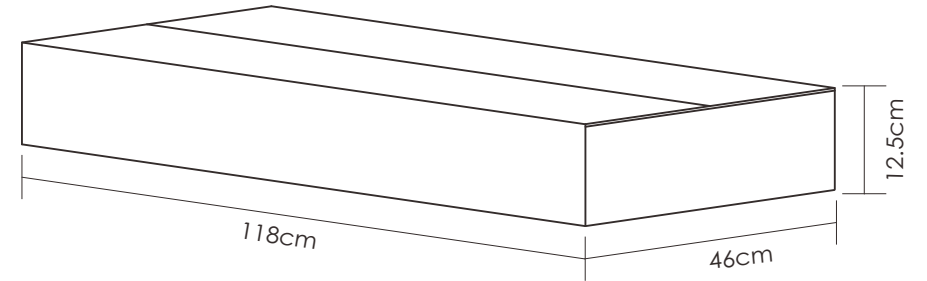

Lamp body

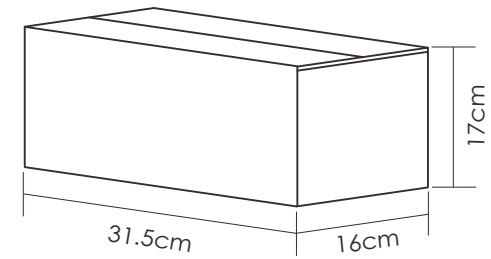

Support frame

P/N	Power	Packing Size(CM)			PCS/CTN	CBM/CTN	G.W/CTN (KGS)	
		L	W	H				
0418B90-03	90W	118.00	46.00	12.50	1	0.0679	13.4	Lamp body
		31.50	16.00	17.00	1	0.0086	1.6	Support frame

### PRODUCT SPECIFICATION

Model	0418C120-03	Product Size
LED Chip	3030LED 96PCS	
Luminous Efficiency	160lm/w	
Color Temperature	6000K	
Solar Panel	6V 100W, Mono-crystalline	
Battery Type	LiFePO4 3.2V 86AH	
Charging Time	6-8 hours	
Discharging Time	30-36 hours	
Control Way	Motion Sensor+Light Control	
Material	Aluminum alloy	
Product Size	1496*407*209mm	
Install Height	6-8m	
Warranty	3 Years	

### PACKAGING SPECIFICATION

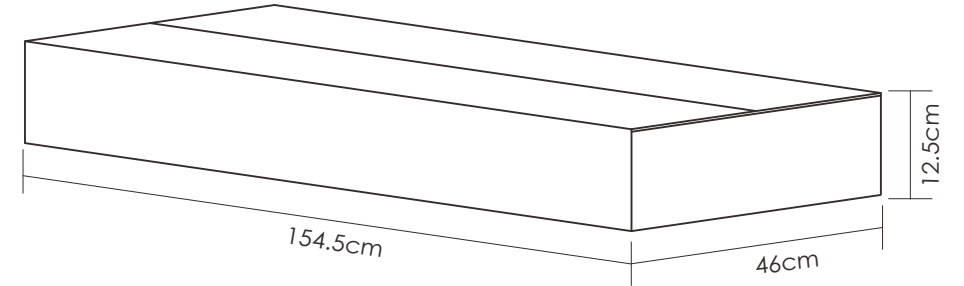

Lamp body

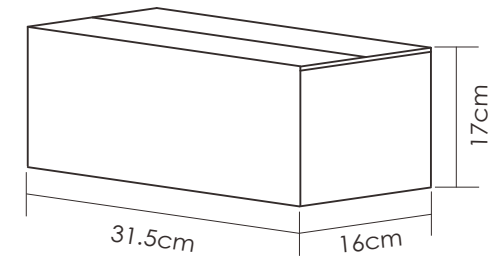

Support frame

P/N	Power	Packing Size (CM)			PCS/CTN	CBM/CTN	G.W/CTN (KGS)	
		L	W	H				
0418C120-03	120W	154.50	46.00	12.50	1	0.0888	15.5	Lamp body
		31.50	16.00	17.00	1	0.0086	1.6	Support frame

### PRODUCT SPECIFICATION

Model	0418D150-03	Product Size
LED Chip	3030LED 120PCS	
Luminous Efficiency	160lm/w	
Color Temperature	6000K	
Solar Panel	6V 120W, Mono-crystalline	
Battery Type	LiFePO4 3.2V 129AH	
Charging Time	6-8 hours	
Discharging Time	30-36 hours	
Control Way	Motion Sensor+Light Control	
Material	Aluminum alloy	
Product Size	1651*407*209mm	
Install Height	8-10m	
Warranty	3 Years	

### PACKAGING SPECIFICATION

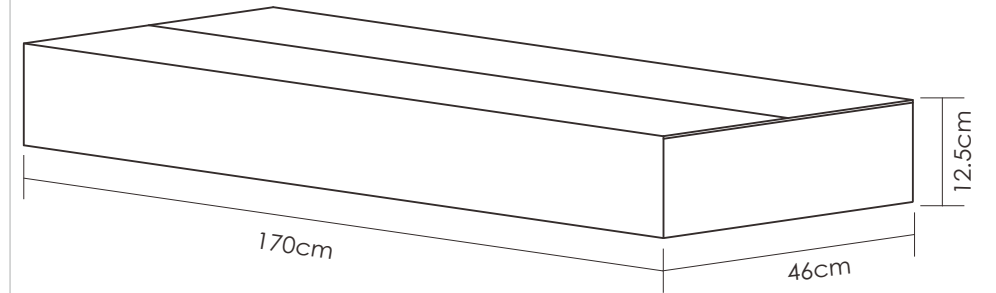

Lamp body

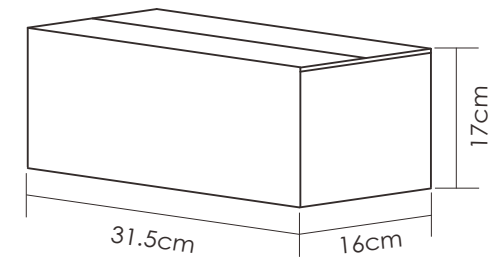

Support frame

P/N	Power	Packing Size(CM)			PCS/CTN	CBM/CTN	G.W/CTN (KGS)	
		L	W	H				
0418D150-03	150W	170.50	46.00	12.50	1	0.0978	17	Lamp body
		31.50	16.00	17.00	1	0.0086	1.6	Support frame

## INSTALLATION GUIDE

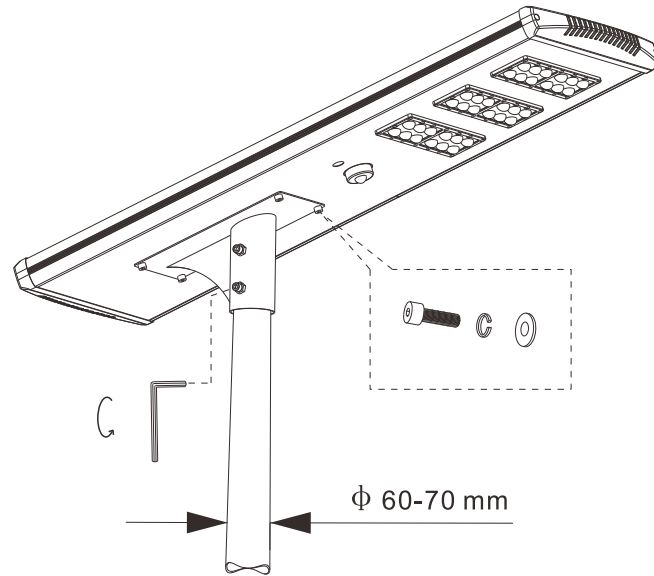

### WARNING

- Please avoid looking directly at the light.
- Dismantling process must be carried out in a safe place.
- Do not short-circuit, disassemble; do not put in the water and near the fire.
- Without the guidance of experts, users are forbidden to repair or dismantle the lights; The supplier shall not be responsible for any consequences owing to incorrect operation or wrong maintained by users.

1. Insert the lamp arm into the lamp body and tighten the screw.
2. Please select the appropriate product according to the installation site's sunlight intensity and required operating time. If you are in the northern hemisphere, face the solar panels towards the south as far as possible when installing the solar light; if you are in the southern hemisphere, face the solar panels towards the north.

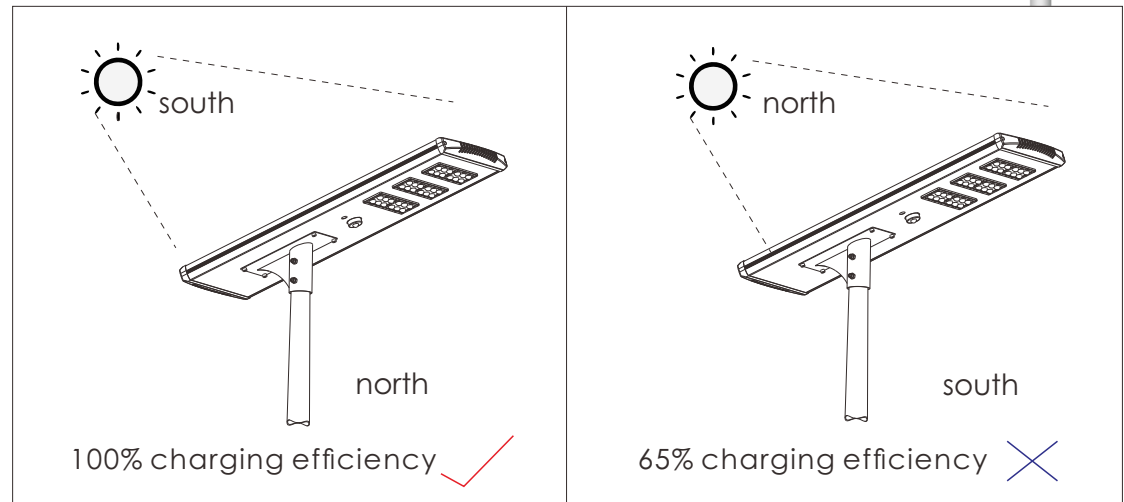

(A diagram for how the orientation impacts on power generation efficiency)

## APPLICATIONS

