

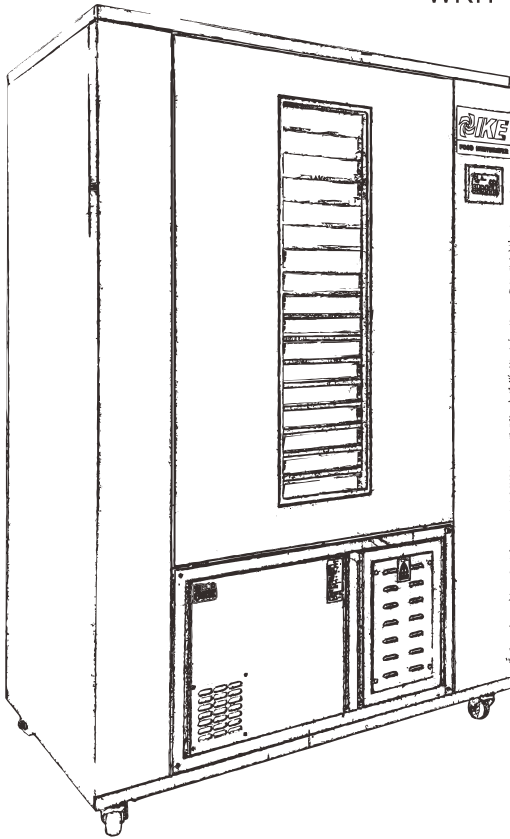

Closed-Loop Heat Pump Dehydration Dryer

WRH-100AN/GN Series



Operation Manual

IKE Group
Guangdong IKE industrial Co. Ltd

Catalog

Chapter 1. Preface	
1.1 Working Theory and Unique Feature -----	1
Chapter 2. Product Structure	
2.1 Main Body of the Dryer -----	3
2.2 System Electrical Wire Connection -----	4
Chapter 3. Operation Instruction	
3.1 Controller (System Control Panel) -----	5
3.2 Turning on and off the System -----	5
3.3 Operation Monitor -----	6
3.3.1 System Menu Operation -----	7
3.3.2 System Setting -----	7
3.3.2.1 Operation Mode -----	7
3.3.2.2 Operation Parameters -----	10
3.3.2.3 Network Setting -----	11
3.3.2.4 System Clock -----	11
3.3.2.5 Change Password -----	12
3.3.2.6 Restore Factory Parameters -----	12
3.3.3 Operation Condition -----	12
3.3.4 Network Status -----	12
3.3.5 Malfunction Diagnosis -----	13
3.3.6 Data Synchronization -----	13
3.3.7 Software Version Information -----	13
3.4 Flow Chart of Basic Operation -----	14
Chapter 4. Appendix	
4.1 Calculation of the Amount of the Material to Be Dried and the Drying Time -----	15
4.2 Tray Dimension, Style and Airflow Pattern -----	17
4.3 Accessory List -----	18
4.4 Main Technical Parameters of the Equipment -----	18
4.5 Articles on Post-sale Service -----	19

1.1 Working Theory and Unique Features

Thank you and congratulation for your wise purchase of the closed-loop heat pump dehydration dryer IKE developed and manufactured for its valued customers!

The IKE patented closed-loop heat pump dehydration dryer makes a breakthrough to the drying theories that have been followed for thousands of years. It replaces the traditional open-loop vaporization drying by the innovative closed-loop dehydration drying, achieving 100% energy recycled. It has been successfully used to dry agricultural produces, fishery products, precious Chinese medical herbs, tobacco, linen and clothes, and wood. It has also been used in other industrial areas such as painting, electrostatic coating. In each case, the drying quality far exceeds our expectation.

With closed-loop dehydration, we place the material to be dried inside a heat-preserved insulated drying house. The circulating hot and dry air first absorbs the moisture inside the material and passes through a cold panel in the dryer. Then the moisture is condensed into water and released from the drying house. Because no hot vapor is lost during the drying process, no energy is wasted. Therefore, the IKE closed-loop heat pump dehydration dryer is highly efficient with low energy consumption. With one kilowatt of electricity, it can remove 3.5 kilograms of water from the material, compared to only 1.2 kilograms of water using the traditional open-loop drying method.

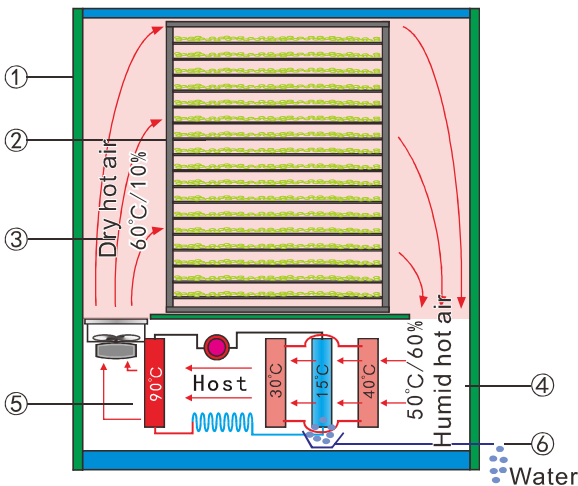

Description of Parts:

1. Drying house
2. Material to be dried
3. Hot and dry air (do not block the space 600mm from the bottom of the drying house)
4. Hot and humid air
5. Core body of the dryer
6. Condensed water (released from the drying house)

As illustrated by the above figure, the compressor inside the heat pump dehydration dryer forms a 15°C cold panel and a 90°C hot panel. Circulated by a fan, the air inside the drying house first passes through the hot panel to become 65°C hot air. The hot air then heats the material to be dried, absorbs its moisture, and becomes 55°C hot and humid air. When it passes through the cold panel, the moisture in the air is condensed into water and released from the house. After dehydration, the air passes through the 90°C hot panel again to become 65°C hot air, and the whole process starts again. As the process repeats, more and more moisture in the material is removed and eventually the material becomes dried.

The IKE closed-loop heat pump dehydration drier eradicates all problems associated with the traditional open-loop drying method. It has the following unique features:

1. Only water is released from the drying house; no energy is wasted (100% energy recycled). High efficiency (several times more efficient than the traditional open-loop drying method).
2. The high efficiency is year-round since it is independent of the surrounding temperature and humidity. Therefore, it can be used in any location with any climate condition.
3. Outside pollutants cannot get into the drying house. This keeps the material extremely clean.
4. The active ingredient in the material will not be lost. This greatly improves the quality and class of the dried material.
5. The dryer can be programmed to perform fast drying in low temperatures, helping maintain the good quality and appearance of the dried material.
6. The material will not deteriorate during the drying process.
7. Strong air circulation leaves no dead spot and guarantees uniform drying.
8. Labor cost can be greatly reduced since no manual flipping is needed.
9. All-in-one design makes installation extremely easy and helps the dryer maintain stable performance.
10. Programmable operation system achieves artificial intelligence control and demands no human on duty
11. Drying temperature, humidity and length can be programmed by stage.
12. Layer-rack drying structure, together with different trays, makes the dryer adaptable and flexible.

The IKE closed-loop heat pump dehydration drier will completely change the traditional drying industry, taking us to a brand new era of energy-saving, environmentally friendly, healthy and safe, high quality and efficient drying!

Drying is a science and art. Different materials have their own drying parameters such as temperature, humidity, length of drying time, etc. Please read this manual carefully before operating the machine in order to maximize the return of your investment.

Chapter 2. Product Structure

2.1 Main Body of the Dryer

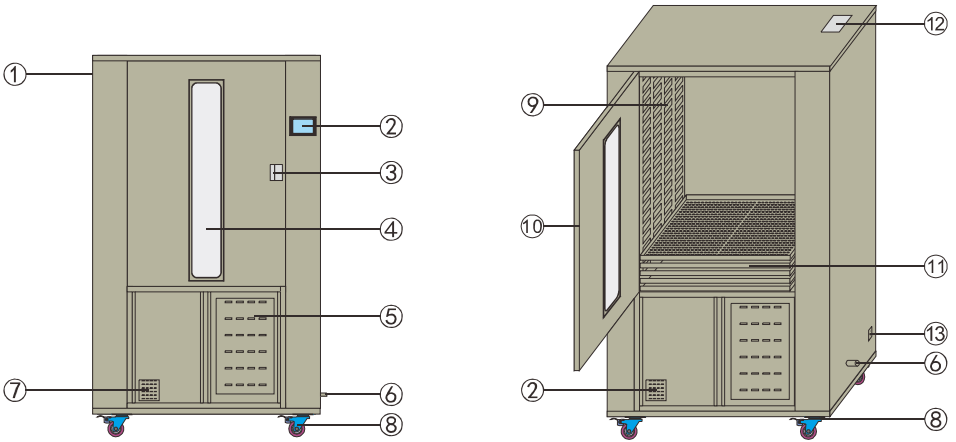

Description of Parts :

1. Drying house
2. Controller
3. Door lock
4. Observation window
5. Electrical Controller Box
6. Water outlet (3/4 inch diameter)
7. Air Pressure Balancing Valve
8. Supporting wheels
9. Outlet for hot and dry air
10. Stainless Steel Insulation Door
11. Drying goods tray
12. Exhaust air inlet for overheating
13. Power jack



Tray Placement

100N series machines can use PP plastic trays with size: 800mmX600mmX60mm. The plastic trays are placed into the machine cabinet in a direct stacking way, no tray racks are needed. Each machine can put 20 pcs, as shown in the right picture.

Stainless steel mesh trays are also available, but require a tray rack. Plastic trays and stainless steel trays can not be used at the same time.

2.2 System Electrical Wire Connection

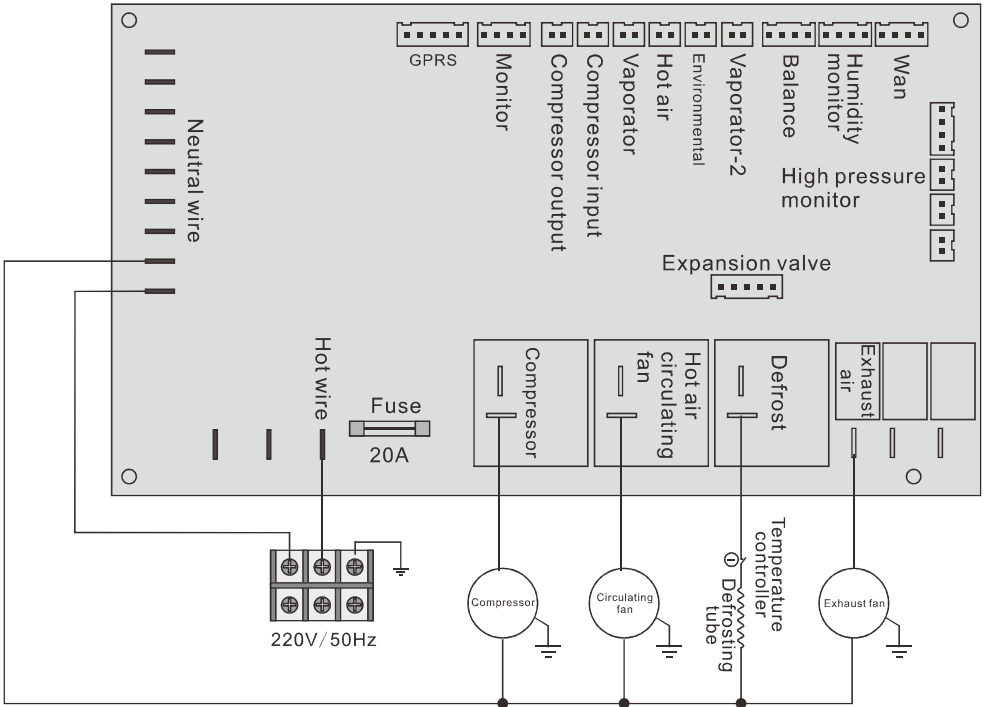

Warning:

1. The power supply wires should be copper wires with the grade higher than IEC57 and the cross sectional area at least 2.5mm². Install a power surge and leakage protector and securely connect the dryer's ground wire to the ground.
2. When the system behaves abnormally, please shut down the power supply immediately. Do not try to disassemble the machine. Ask a professional to diagnose and repair.
3. If you sense something wrong, please turn off the machine first. Then turn on to operate the machine.

Chapter 3. Operation Instruction

3.1 Controller (System Control Panel)

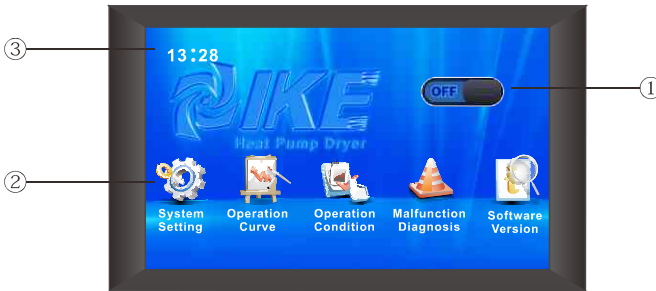

Function of keys:

- ① ON/OFF: Touch ON/OFF and follow the indication to turn on or turn off the system.
- ② Main Menu: Select and touch to execute the corresponding function
The initial password to enter “ System setting” is “111111”.
- ③ Time: The current time of the system.

3.2 Turning on and off the System

Touch “  ” to enter the interface to turn on or turn off the system.

When the system is under non-fixed time drying mode: you will see the interface as the right one, then follow the instruction to turn on or turn off the system.



When the system is under fixed time drying mode, you will see the interface as the right one, then follow the instruction to turn on or turn off the system.

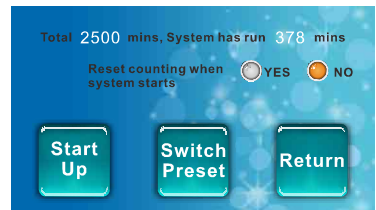

3. 3 Operation Monitor

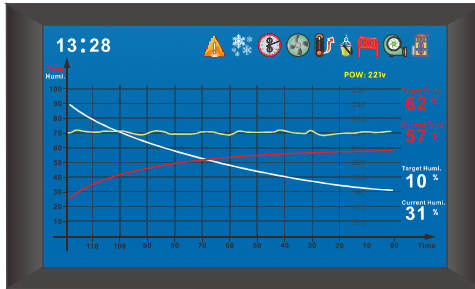

Icons in operation curve interface:

Current Time: Displayed at the upper left corner. It is 13:28 in the figure.











Humidity history: The current humidity show as 31% RH, displayed at the right side.

Temperature history: The current temperature show as 57° C, displayed at the right side.

Current Progress & History Curve: White line for humidity curve, red line for temp curve.

Voltage curve: This curve is the current power supply voltage entering the machine. When the voltage exceeds or falls below the specified range, the system will automatically shut down for protection. Please ensure that the power supply is stable during use.

System symbols: Displayed at the upper right corner with the following meaning:

-  : Condition for the hot air circulating fan, indicated by a cartoon when in operation.
-  : Compressor Working
-  : Defrost Or Fast-Heat Started
-  : System malfunction; Detailed information can be obtained from "malfunction diagnosis" in the menu.
-  : Fixed time drying mode is selected
-  : The system is heating
-  : System NO need heating but for cooling (Ex. Low temperature dryer in cooling status)
-  : The system is dehydrating
-  : System NO need dehydrating
-  : Defrosting

Chapter 3. Operation Instruction

3.3.2 System Setting

Set up password protection the first time in System Setting, the password should be 6 digits long. Initial password is 111111.

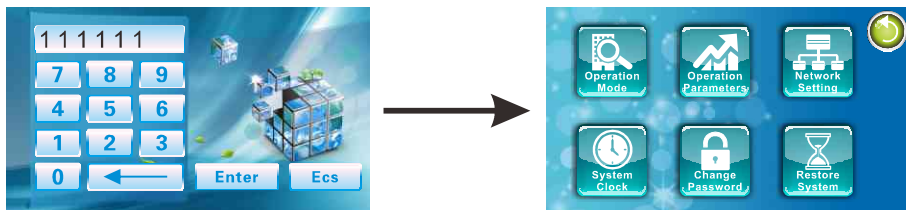

3.3.2.1 Operation Mode

3.3.2.1.1 Constant Temperature & Humidity Mode

In this mode, the system tries to maintain both temperature and humidity in the drying house at the preset values. When the temperature reaches the preset value but the humidity is still too high, the system continues performing dehumidification while maintaining constant temperature. When the humidity reaches the preset value but the temperature is still too low, the system will continue heating while maintaining constant humidity.

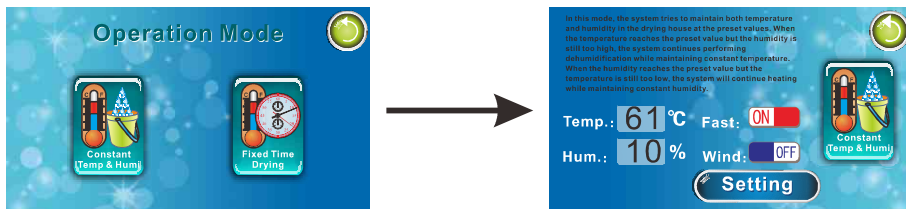

Note(100D and 100T don't have this function):

- **Fast Dehumidification:** Some special materials may not need fast dehumidification in some stage of the drying process. Instead, they may need rising temp and high humidity for some time period. It can be achieved by selecting this feature.
When “Fast Dehumidification” is selected, the system performs ehumidification at its maximum capacity. When this feature is not selected, the system performs dehumidification slowly at a gradual rate. In this case, the ehumidification result depends more on the current temperature and humidity inside the drying house. Thus, it is recommended to inspect the drying periodically the first time.
- **Wind:** When “Wind” is selected, the circulating fan is running continuously during the whole drying process. When “Fan On” is not selected, the fan will stop running once both the temperature and humidity reach the preset values. It will resume running if there is a change in the temperature and/or humidity until the temp and humidity reach their preset values.

3.3.2.1.2 Fixed Time Drying

In Fixed Time Drying Mode, you can specify several stages with different time lengths and different target temperature and humidity values.

For example, if you would like the system to run for 2 hours with 30°C temperature and 70% humidity, then for 5 hours with 40°C temperature and 50% humidity, and finally with 60°C temperature and 20% humidity, you can enter these three sets of parameters to the system, and it will automatically run in order according to the set parameters. Therefore, no human on duty is necessary.

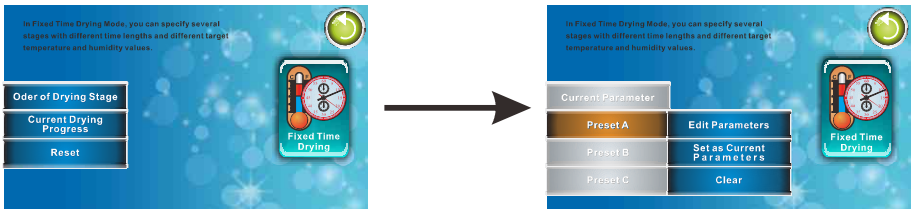

Note :

- **Time stage setting:** set parameter values for fixed time drying mode;
- **Current progress:** Check the amount of time the system has run for the current stage and the whole Fixed Time drying mode.
- **Reset Timing:** The system will repeat the current fixed drying mode, starting from stage 1.

For example, after the first batch of the material has been dried, place the second batch of the (same) material in the drying house, then press "Reset Timing". The system will repeat the current fixed time drying mode, starting from stage 1.

- **Current Parameters:** List of all parameters the system is currently using; enter to check or modify running parameters for a stage.
- **Preset Parameters:** For sake of convenience, the system provides three presets that allows a customer to save up to three different fixed time drying modes for future repeated use.

Each time when a preset is selected, the system will automatically use the preset parameters as the current parameters (the previous "current parameters" will be replaced by the preset parameters).

Therefore, temporary fixed time drying mode needs to be set in "Current Parameters", while fixed time drying modes that will be repeatedly used for a long time need to be saved as "Preset Parameters" to avoid them being accidentally replaced.

- Once the power supply is back after the system is interrupted by a power outage during the drying process, the system will resume running according to the operation parameters before the power outage.

Chapter 3. Operation Instruction

Four operation modes: constant temperature, constant humidity, constant temperature and humidity, and fixed time drying, can be selected. The system will start working once the desired parameters for a selected mode are entered. The following is an illustration for the "fixed time drying" mode with 3 drying stages.

Order of the drying stages

The objective temperature for a drying stage

The objective humidity for a drying stage

Length of the stage in minutes

Choice of fan operation and dehumidification mode

It shows that the target temperature is 40°C and the target humidity is 80% for stage 1 with slow dehumidification; when the target temperature and humidity are achieved, the circulating fan stops running. The time length of stage 1 is 560 minutes. The system will start stage 2 once stage 1 is completed.

It shows that the target temperature is 50°C and the target humidity is 50% for stage 2 with fast dehumidification; when the target temperature and humidity are achieved, the circulating fan stops running. The time length of stage 2 is 390 minutes. The system will start stage 3 once stage 2 is completed.

It shows that the target temperature is 60°C and the target humidity is 20% for stage 3 with fast dehumidification; when the target temperature and humidity are achieved, the circulating fan not stops running. The time length of stage 3 is 160 minutes. The system will stop running once stage 3 is completed.

Note:

- If the humidity parameter is set but the temperature parameter is blank with only two underlines, the stage is in constant humidity mode.
- If the temperature parameter is set but the humidity parameter is blank with only two underlines, the stage is in constant temperature mode.
- If the temperature parameter is set and the humidity parameter is set as 00, the stage is called "Sterilization" (Just the model No. 100B and 100G could use the "Sterilization" function ; 100D and 100T don't have this function.)

In the "Sterilization" stage, the temperature inside the drying house will increase rapidly to a high number and maintain the value for some period of time (the system's sterilization temp is 75°C).

For example, if a material needs to be sterilized at 70°C for 10 minutes before being dried at 60°C, then this can be set as illustrated by the right figure (the time before the sterilization temp is achieved is not counted towards the sterilization time).

NO.	Temp.	Humi.	Time	Fast	Wind	Set
01	70	00	10	ON	ON	Set
02	60	10	990	ON	ON	Set
03						Set
04						Set

Clear Next

3. 3. 2. 2 Operatation Parameters

Fast heating: For some special products that require the temperature in the drying house to rise in a short time, this function can be activated to quickly reach the desired temperature (during fast heating, the total system energy consumption will increase by 1000W) .

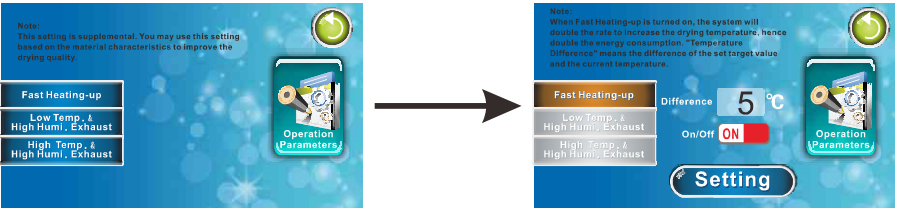

Exhaust fan on at low temperature and high humidity: If this function is activated, the exhaust fan will be automatically turned on when the current temperature is below the set temperature, and the current humidity is above the set humidity (appropriate for goods such as seafood).

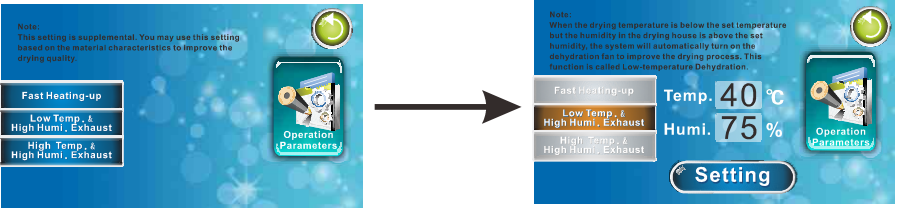

Exhaust fan on at high temperature and high humidity: If this function is activated, the exhaust fan will be automatically turned on when the current temperature is above the set temperature, and the current humidity is also above the set humidity. This function can speed up dehydration and improve efficiency.

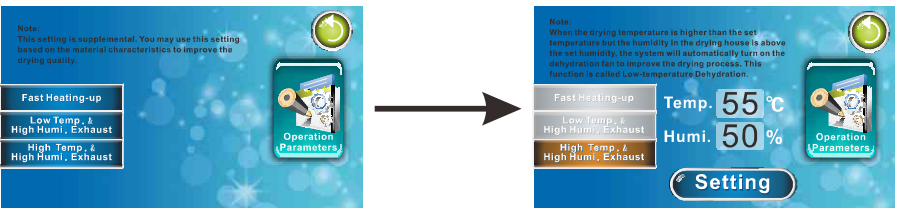

Remark: The model No. WRH-100D / WRH-100DS do not have these two functions: “Exhaust fan on at low temperature and high humidity”, and “Exhaust fan on at high temperature and high humidity”.

Chapter 3. Operation Instruction

3. 3. 2. 3 Network Setting

Optionally, this system can be equipped with a “Cloud Management” module so that the system can be connected to the internet for the purpose of remote monitoring, management and maintenance. This feature is very useful for managing multiple drying machines.

IP address: Set the Local Area Network (LAN) IP address for the drying machine. This address is required for the management software to be available to the machine.

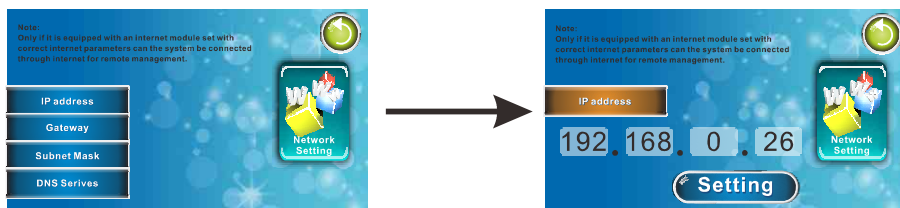

Subnet Mask: Set this network connection parameter based on the LAN parameters.

Gateway: If remote internet management is needed, this Gateway parameter has to be provided to the system.

Note: The current network connection for the machine can be checked in “Network Status” of the basic menu.

Remark: This “Network Setting” function is for user's choice, and base on the matching between this function and the user's local network system.

3. 3. 2. 4 System Clock

The accuracy of the system clock is very important to its operation that requires the function of fixed time drying. The system clock should be correctly set up before operation and should be checked and adjusted if necessary every month.

3. 3. 2. 5 Change Password

Change the password for the system setting.

New password has to be 6 digits long. If you forget your password, please consult with your agent or directly contact IKE.

It does not require a password to check operation parameters. However, it requires the password to set up parameters such as humidity and temperature, to prevent the system from being mistakenly interrupted.

3. 3. 2. 6 Restore Factory Parameters

The system parameter be restored to the default factory parameters.

- Temperature : 60 °C
- Humidity 10%
- Operation mode: constant temperature and constant humidity

3. 3. 3 Operation Condition

The operation monitor displays the current working parameters and condition of the system, such as the current temperature, humidity, and whether a component is working or not. The information is very important to the diagnosis of any potential problem of the system.

3. 3. 4 Network Status

After equipped with a “Cloud Management” module, the network connection status of the system can be checked through this menu.

Current status: shows if the system is in the logged in status.

Connection status: shows if a remote management terminal is connected with the system.

Device ID: Each drying machine has a unique device identification number (Device ID). If remote internet management is needed, provide this ID to IKE as the identification proof. When using customer software, provide this number to the software so that the management terminal can connect to the machine normally.

Chapter 3. Operation Instruction

3. 3. 5 Malfunction Diagnosis

When the system indicates malfunction, "Malfunction Diagnosis" provides detailed information useful for the diagnosis and repair of the problem.

Malfunction	Suggested Solution
Temperature sensing error	Check the sensor connection or replace the temperature sensor
Humidity sensing error	Check the sensor connection or replace the humidity sensor
Returned air temperature sensing error	Check the sensor connection or replace the returned air temperature sensor
Compressor temperature sensing error	Check the sensor connection or replace the compressor temperature sensor
Vaporator temperature sensing error	Check the sensor connection or replace the vaporator temperature sensor
Compressor high pressure protection	Restart the machine
Compressor low pressure protection	Restart the machine
Abnormal system communication	Check to see if panel circuit is too close to high voltage source
Compressor output temperature is too high	Poor circulation; Adjust the density of the material or clean the heat exchanger

3. 3. 6 Data Synchronization

Manual data synchronization is only required after replacing a controller monitor or system control panel. Usually the system performs data synchronization automatically.

3. 3. 7 Software Version Information

Displays version number of the software used in the system and the controller. When the system malfunctions, please obtain the version information through this operation and forward it to a technician in order for him/her to have a more accurate diagnosis of the malfunction.

3. 4 Flow Chart of Basic Operation

Step 1: Set target temperature and humidity parameters in “Operation Mode”

- The initial password is “111111”
- Can adjust different parameters at any time, even if the system is running. The newly set parameters will be effective immediately.

Step 2: Select or un-select “Fast Heating” in “Operation Parameters”

- “Fast Heating” can be selected any time when the system is running.
- The target temperature for “Fast Heating” is usually set at 5° C below the final target temperature.

Step 3: Turn on/off the machine by touch the on-off key in the interface

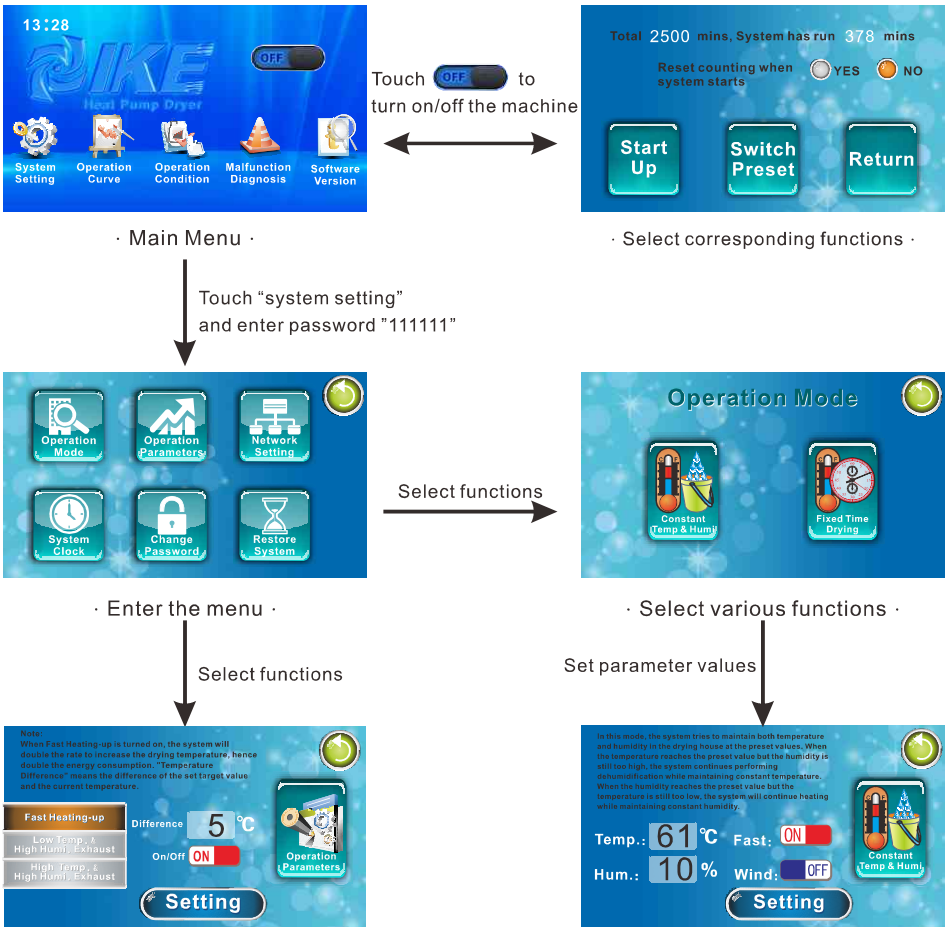

4. 1 Calculation of the Amount of the Material to Be Dried and the Drying Time

The amount of material a dryer can dry each time depends on the characteristics of the material and final drying quality. In general, it can be calculated in the following way:

1. Determination of the characteristics of the material to be dried.

Before launching a large scale drying, we need to conduct a small experiment with small amount of the material (usually about 5 to 10 kilograms) to determine the drying characteristics of the material, including drying temperature, humidity, dehydration ratio and the minimum drying time required to achieve the desired result.

- **Dehydration ratio:** $(\text{weight before drying} - \text{weight after drying}) \div \text{weight before drying}$, usually expressed in percentage.
- **Minimum drying time:** The total drying time from the beginning of drying to the time point where desired drying result is achieved, usually expressed in hours.

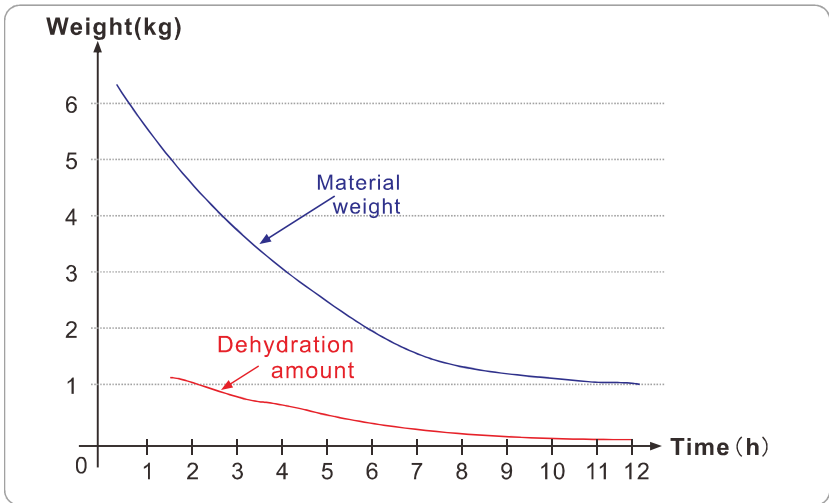

Description: The drying curve for chayote at 60°C drying temperature. It can be seen from the figure that the dehydration ratios in the early and later 6 hours are about 70% and 17% respectively, with the overall dehydration ratio being about 87%. The figure also indicates that the minimum drying time for the chayote is 12 hours.

2. Calculate the drying load of the material (the max dehydration per day)

Drying load: weight of the material to be dried per day \times dehydration ratio

3. Determine the number of dryers (Take WRH-100B for example)

With WRH-100B, the dehydration capacity is 2 kilograms of water per hour, or approximately 50 kilograms of water per day.

· **Number of dryers needed:**

Drying load \div dehydration capacity \times safety coefficient

(In the later drying stage, dehydration becomes more difficult. Therefore, we recommend to consider a safety coefficient between 1.2 and 1.5.

Meanwhile, consider purchasing and installing at least 2 dryers so that a backup machine is ready to handle any emergency.)

4. Calculation of the amount of the material for each drying

Amount: dehydration capacity of the dryer per hour \times expected drying time \div dehydration ratio of the material.

- The expected drying time has to be longer than the minimum drying of the material. For the material that is not easy to deteriorate, the expected drying time can be set much longer than the minimum drying time to reduce number of times to load and unload the goods.
- In the later drying stage, the amount of moisture in the material, as well as its surface and volume have been greatly reduced. In this stage, dehydration becomes more and more difficult. If we keep the early drying pattern for this stage, we can't take full advantage of the efficiency of the machine. Therefore, we should adapt multiple stage (at least 2 stage) drying. That is, when the drying reaches certain degree, we put the goods from several drying houses together to conduct second stage drying.
- To increase the overall surface of the material so to increase the vaporization speed, it is acceptable to place more material (even several times more) in the drying house. Of course, the drying time will also increase.
 From the drying curve for chayote, its minimum drying time is 12 hours, with 70% dehydration ratio in the first 6 hours and 17% dehydration ratio in the second 6 hours respectively. Taking into account workers' schedule, one may double the drying time for chayote so that the dehydration ratio for the first and second 12 hours are 70% and 17% respectively.

Then at the beginning, a drying house can accommodate (12 hour \times 2 kilograms / hour) \div 70% = 34 kilograms of chayote.

Chapter 4. Appendix

For example, you have 100 kilograms of the material to be dried, and its weight is only 30% of the original weight when it is completely dried. Then

Step 1: Calculate the number of dryers

- Dehydration ratio = $(1-0.3) = 0.7$, or 70%
- Drying load per day $100 \times 0.7 = 70$ kilograms
- Number of dryers needed = $70/50 = 1.4$ (50 is machine's dehydration capacity per day)
- Suppose you use 1.2 as the safety coefficient
Final number of dryers actually needed = $1.4 \times 1.2 = 1.7 \approx 2$

Step 2: Calculate the amount of the material to be placed in the dryer each time

- Suppose the minimum drying time is estimated to be 4 hours.
- The amount = $2 \text{ kilograms/hour} \times 4 \text{ hour} \div 0.7 = 11.4 \text{ kilograms}$
That is, you can place 11.4 kilograms of the material each time.
Repeat this for every 4 hours.

4.2 Accessory List

- ① Machine control panel (installed inside the dryer): 1
- ② Power connection cord (2 meters long, 16 A): 1
- ③ Operation manual (including warranty card): 1
- ④ Product qualification certificate: 1
- ⑤ Drying goods tray: 1
- ⑥ Water collection tray (installed inside the dryer): 1

4.3 Main Technical Parameters of the Equipment

Model	WRH-100AN / WRH-100GN
Designed power input	1.1 kw
Maximum power input	2.4 kw
Max temp of the hot air	65°C / 80°C
Best Drying Temp	50°C—63°C / 50°C—75°C
Suitable surrounding temperature	5°C—+40°C
Dehydration efficiency	≥3.0 kg/kwh (@50°C、80%)
Dehydration capacity	≥3.0 kg/h (@50°C、80%)
Noise level	≤55dB(A)
Ground connection requirement	≤0.1 Ω
Drying goods tray (LWH)mm	780×540×30
Drying house dimension(mm)	1280×700×1860
Insulation board	Foam sandwich insulation board

4. 5 Articles on Post-sale Service

1. IKE provides one year warranty for the product. Under the warranty, IKE provides free repair service for system malfunction and product defect. Contact your agent for the detail.

2. The following problems are not covered by the warranty. The customers will be charged appropriately for the subsequent diagnosis and repair performed by IKE.
 - Malfunction caused by disassembling and/or repair by any person(s) or party (parties) that are not authorized by IKE.
 - Malfunction caused by un-authorized (by IKE) modification, addition, augmentation, or other un-authorized operations to the machine.
 - Malfunction caused by unavoidable elements such as flood, fire, earthquake, thunder strike and wind disaster.
 - Malfunction caused by wrong operation and use, poor management of the machine, or any other human mistakes.

3. Under no circumstance will IKE be responsible for the loss of the material to be dried due to the malfunction of the machine.



Sales Center : No.3 ,Keyuan Road , Shishan Science & Technology Park,
Nanhai ,Foshan City,Guangdong Province ,China

Production Base: West Meizhou Road ,Meizhou High-tech Zone,Shejiang,
Meizhou City ,Guangdong Province,China

Tel: (+86) 757 83338767

Fax: (+86) 757 89914218

Web Site: www.ike.cn

E-mail :ike@ike.cn