



Digital Online COD Sensor

Model: Cods-3000-01 Operation Manual



SHANGHAI BOQU INSTRUMENT CO.,LTD

Address:No. 118 Xiuyan Road,Pudong New Area,Shanghai,zip code:201315,China

www.boquinstrument.com | email:michael@shboqu.com | mob:86-15000087545

Catalog

Chapter 1 Product Specifications.....	1
Chapter 2 Product Overview.....	2
2.1 Product Information.....	2
2.2 Safety Information.....	3
Chapter 3 Installation.....	4
3.1 Installation of Sensors.....	4
3.1.1 Handrail-style Installation.....	4
3.1.2 Poolside Installation.....	5
3.2 Connection to Sensor.....	6
Chapter 4 Calibration of Sensor.....	6
4.1 Factor Calibration.....	6
4.2 Zero Calibration.....	7
4.3 Water samples calibration.....	7
4.4 Preparation of standard solution.....	7
Chapter 5 Telecommunication.....	8
Chapter 6 Maintenance.....	11
6.1 Cleaning of Sensor.....	11
6.2 Damage Inspection of Sensor.....	12
Chapter 7 Special Instruction.....	12

Chapter 1 Product Specifications

Specification	Details
Measurement Range	0~2000mg/l COD (2mm Optical Path) 0~1000mg/l COD (5mm Optical Path) 0~90mg/l COD (50mm Optical Path)
Measurement Accuracy	±5%
Measurement Interval	At least 1min
Pressure Range	≤0.4Mpa
Material	Main Body: SUS316L (Ordinary Version), Titanium Alloy (Seawater Version) Upper and Lower Cover: PUR
Compensating Wavelength	540 mm
Power Supply	9-36V
Communication Protocol	MODBUS RS485
Storage Temperature	Between -15 to 65°C
Operating Temperature	Between 0 to 45°C
Dimension	Diameter 69mm * 365mm(Ordinary Version) Diameter 69mm * 368mm(Seawater Version)
Weight	3.2KG
Level of Protection	IP68/NEMA6P
Cable Length	10-meter standard cable which can be extended up to 100 meters.

Table 1 Technical Parameters of Spectral COD Sensor

Note: The specifications of the product are subject to change without prior notice.

Chapter 2 Product Overview

2.1 Product Information

Based on the absorption of ultraviolet light by organic matter, spectroscopic organic material online sensor adopts the 254 nm spectral absorption coefficient SAC254 which is used to reflect the important measurement parameters of the soluble organic matter content in water, and it can be converted into COD value under certain conditions. This method allows for continuous monitoring without the need for any reagents.

It is widely used in the continuous monitoring of organic matter load in the sewage treatment process, on-line real-time monitoring of inlet and outlet water quality of sewage plant; continuous on-line monitoring of surface water, drainage of wastewater from industrial and fishery fields. The dimensions of the sensor are shown in Figure 1.

2mm:

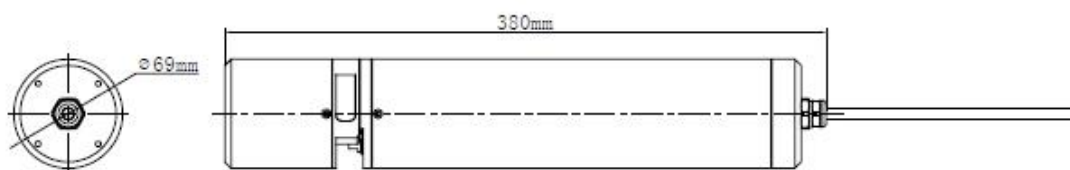

5mm:

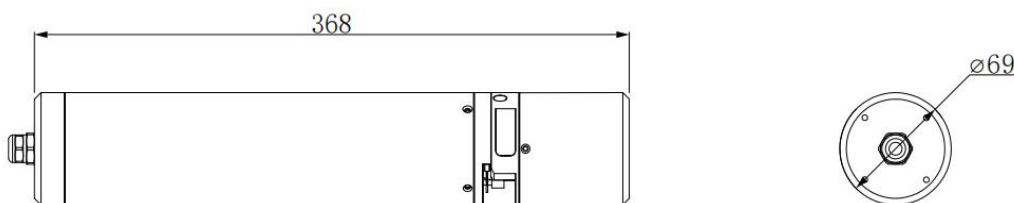

50mm:

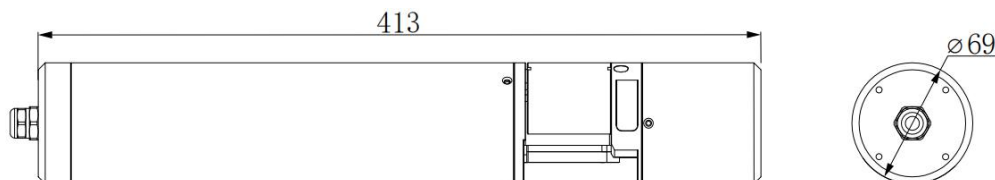

Figure 1 Dimensional Drawing of Sensor

2.2 Safety Information

Please read this manual completely before opening the package, installing or using. Otherwise it may cause personal injury to the operator, or cause damage to equipment.



Warning labels

Please read all labels and signs on the instrument, and comply with the security label instructions, otherwise it may cause personal injury or equipment damage.

When this symbol appears in the instrument, please refer to the operation or safety information in the reference manual.



While this symbol indicates an electric shock or risk of death from electric shock.

Please read this manual completely. Pay particular attention to some notes or warnings, etc. To ensure that the protective measures provided by the equipment are not destroyed.

Chapter 3 Installation

3.1 Installation of Sensors

3.1.1 Handrail-style Installation

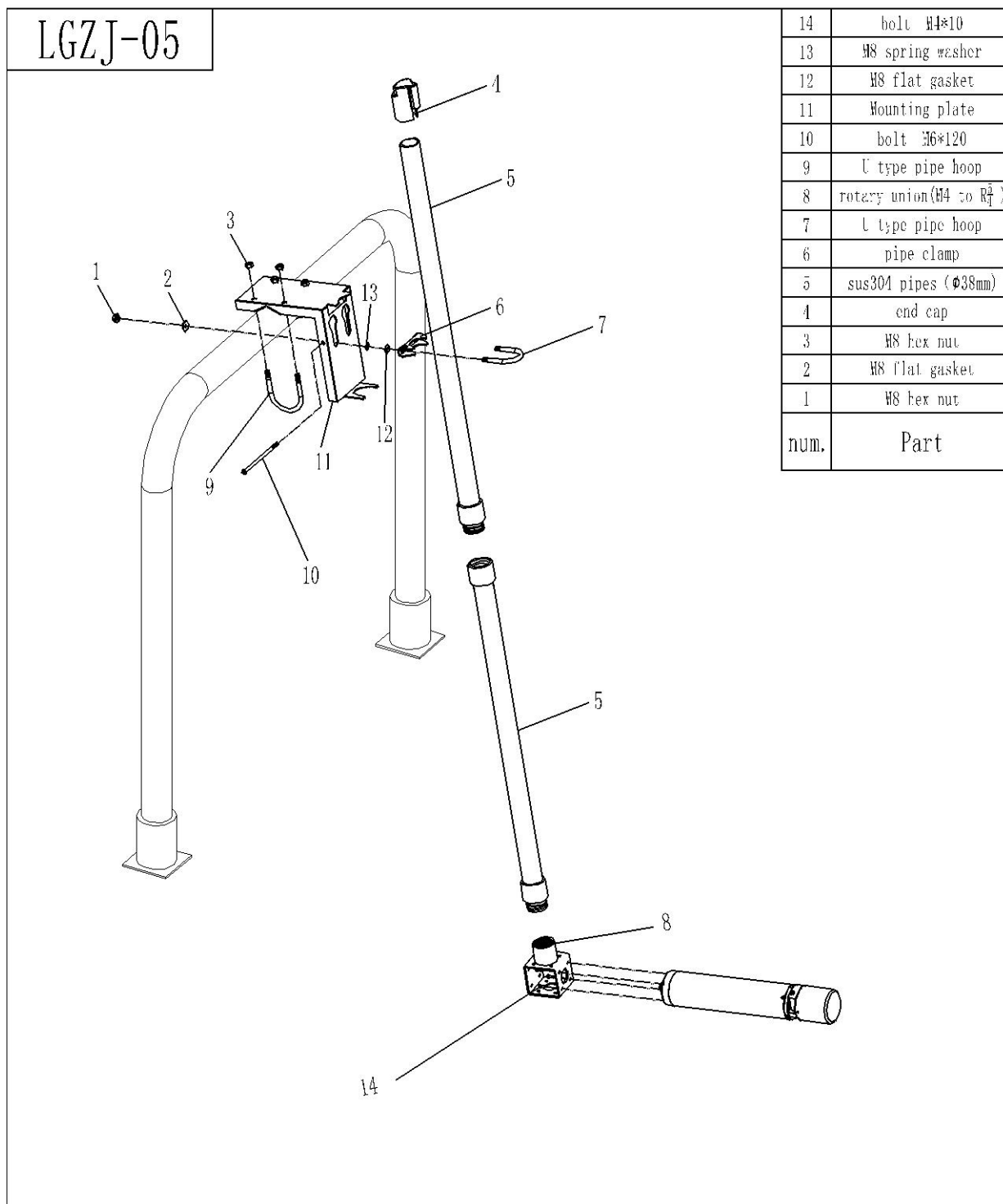

Figure 2 Schematic Diagram of Handrail-style Installation

3.1.2 Poolside Installation

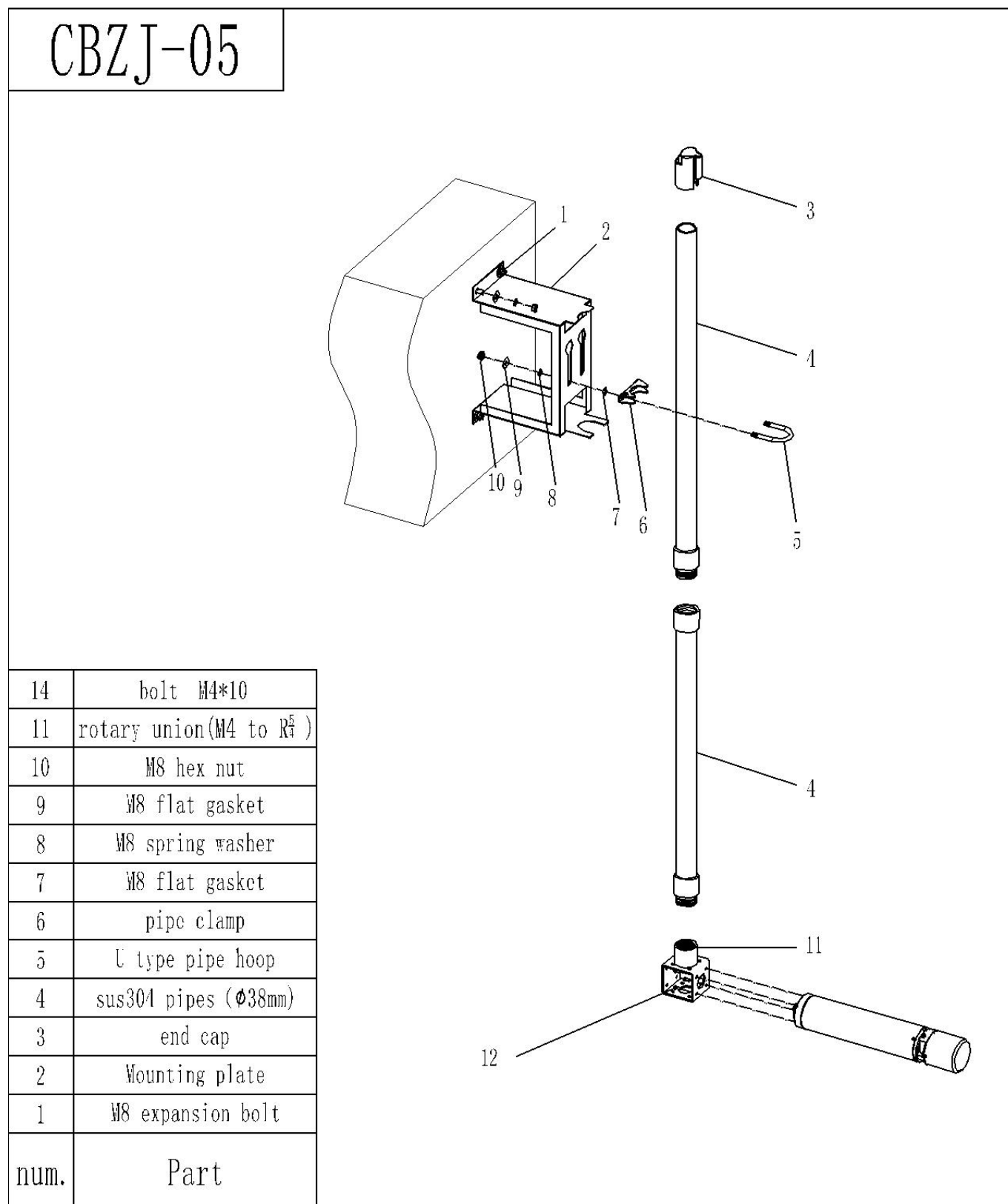

Figure 3 Schematic Diagram of Poolside Installation

3.2 Connection to Sensor

The sensor is correctly connected according to the definition of the following cores:

Serial Number of Cable Core	1	2	3	4	5
Sensor Wire	Brown	Black	Blue	White	Yellow + Green
Signal	+12VDC	AGND	RS485 A	RS485 B	Ground Lead

Chapter 4 Calibration of Sensor

Spectroscopic organic material online sensor has been calibrated at the factory. If there is a need to re-calibrate, please follow the steps below. **(Note: Make sure to clean the glass window before performing the calibration. Depending on the application, any deviation from the factory calibration may be caused by contamination of the optics. If the calibration verification fails, please clean the glass window again and repeat these steps).** The calibration of spectroscopic organic material online sensor includes factor calibration and zero calibration.

4.1 Factor Calibration

If there is a large deviation between the measured value and the standard value, the slope of the calibration curve needs factor calibration.

1. Connect the sensor to the PC;
2. Slowly dip the sensor into the standard solution;
3. Wait till the value is stable and then record the stable value;
4. Complete the calibration by entering the correct extinction value factor (factor range: 0.5-5) in the corresponding register of the factor.

4.2 Zero Calibration

1. Connect the sensor to the PC;
2. Slowly dip the sensor into the distilled water, and make sure the measurement of the light path remain level;
3. After the value stabilizes, carry out zero calibration according to the communication protocol.

4.3 Water samples calibration

If with large deviation between the measured value and the water sample value, then the slope of the calibration curve needs to be factor corrected.

1. Connect the sensor to the PC;
2. Slowly immerse the sensor in the water sample (known concentration);
3. Wait for the value to be stable and calibrate the water sample according to the communication protocol;

4.4 Preparation of standard solution

COD standard stock solution (1000mg/L):

Weigh 0.8502g of potassium hydrogen phthalate (reference reagent) for two hours in a 100mL beaker, add 50mL of distilled water, mix until the reagent is completely dissolved, transfer it to a 1000mL volumetric flask, and dilute to the scale with distilled water. Shake it and store it. (The solution has a COD value of 1000 mg/L)

Preparation of standard solutions:

1. 50mg/L: Measure 50mL of prepared COD stock solution. Transfer to a 1000 mL volumetric flask and dilute to the mark with re-distilled water.
 2. 100mg/L: Measure 100mL of prepared COD stock solution. Transfer to a 1000 mL volumetric flask and dilute to the mark with re-distilled water.
 3. 200mg/L: Measure 200mL of prepared COD stock solution. Transfer to a 1000 mL volumetric flask and dilute to the mark with re-distilled water.
 4. 500mg/L: Measure 500mL of prepared COD stock solution. Transfer to a 1000 mL volumetric flask and dilute to the mark with re-distilled water.
- COD standard stock solution (1000mg/L):

Operation Manual of Digital Online COD Sensor

Weigh 0.8502g of potassium hydrogen phthalate (reference reagent) for two hours in a 100mL beaker, add 50mL of distilled water, mix until the reagent is completely dissolved, transfer it to a 1000mL volumetric flask, and dilute to the scale with distilled water. Shake it and store it. (The solution has a COD value of 1000 mg/L)

Chapter 5 Telecommunication

The sensor embraces MODBUS RS485 communication function which communicates in RTU mode. The specific MODBUS-RTU table is shown in the following table.

MODBUS-RTU	
Baud Rate	19200
Data Bits	8 Bits
Odd-even Check	None
Stop Bit	1 Bit
Function Code	03

Register Name	Address	Date Type	Length	Read/Write	Instruction
03 Function Code					
COD	0	Float		R	COD Value(Unit: mg/L or PPM)
BOD	2	Float		R	BOD Value
TOC	4	Float		R	TOC Value

Operation Manual of Digital Online COD Sensor

UV254	6	Float		R	UV254 Value
Main measuring Value Unit	8	signed		R	0:"mg/L" 2:"PPM"
06 Function Code					
Modify UVCOD Value Unit	8	signed	1	W/R	0:"mg/L" 2:"PPM"
Modify probe parameters	9	signed	1	W/R	Bit 0B1111 is represented from the low position respectively UVCOD No parameters No parameters UV254 Parameters 0: invalid 1: valid
Modify the measurement cycle	10	signed	1	W/R	Measurement Period (Unit: Second) The shortest 15s 15 times (default 30 seconds)
Modify the wiper cleaning cycle	16	signed	1	W/R	4096: Scratch once before measurement (default) Other: wiper cycle (unit: minute) Minimum 1 minute, maximum 720 minutes
Modify the wipe mode	17	signed	1	W/R	0: Dual A-B-A mode 1: double B-A-B mode 2: Single wipe mode

Operation Manual of Digital Online COD Sensor

Modify response time	19	signed	1	W/R	1 2 3 4 : : 12 Max Index: 20
Calibration curve type	188	signed	1	W/R	0:COD Standard curve 1:COD Water sample curve
Modify Baud Rate	61961	signed	1	W/R	0:4800bps 1:9600bps 2:19200bps 3:38400bps 4:57600bps
Modify Slave Address	61967	signed	1	W/R	Slave Address (default 10) Min Address:0 Max Address: 255
Zero Calibration	90	signed	1	W/R	0X3E:62 Zero calibration menu 0X19:25 Preparation 0X12:18 Ready 0X3D:61 Calibration Status 0X55:85 Wipe 0X3D:61 Calibration Status

Operation Manual of Digital Online COD Sensor

					0X13:19 Wait Steady 0X2A:42 End of calibration 0X34:52 Return to main value
16 Function Code					
Factor	184	Float	2	W/R	Range of Factor: 0.0~2.0
Deviation Value	186	Float	2	W/R	Range of Deviation Value: (2mm Optical Path): -1600.0~1600.0 (5mm Optical Path): -800.0~800.0 (50mm Optical Path): -72.0~72.0
Water samples calibration	128	Float	2	W/R	Water samples values

Chapter 6 Maintenance

In order to get the best measurement results, it requires regular maintenance which includes sensor cleaning, checking if the sensor is damaged, and etc. It is also available to check the status of the sensor during maintenance and inspection.

6.1 Cleaning of Sensor

In the measurement path of the sensor, the cleanliness of the two measurement windows is critical to the accuracy of the measurement. The measurement window should be checked if it is contaminated once a week, and the wiper should also be checked once a week to see if is damaged. **The maintenance schedule is shown in the following table:**

Operation Manual of Digital Online COD Sensor

Job Duties	Frequency
Visual Check	Once per week
Checking Calibration	Conduct a comparative measurement once a week (depending on the measurement environment)
Replacement of Wiper Blade	Depend on the actual situation.

Caution: Damage to the sealing structure of the probe will cause water to enter the inside of the probe, which will seriously damage to the equipment, therefore, it should be taken care of during application.

6.2 Damage Inspection of Sensor

Check the appearance of the sensor to see if it is damaged, and if the probe is sealed; if there is any damage, please contact the after-sales service center for replacement to prevent the damage to the sensor from dipping into the water.

Chapter 7 Special Instruction

The self-cleaning wiper is driven by the motor. Do not manually turn it to avoid damage to the internal motor gear. The malfunction/damage caused by turning the wiper manually is not covered by the warranty!