

INKGIANT[®]
Focus on inkjet printing solution

INKGIANT[®]
Focus on inkjet printing solution



DTF PRINTER
BF-60E2-S DTF SOLUTION

🌐 www.inkgiant.com.cn

✉ info@inkgiant.com.cn

☎ 86-0371-5596-0872

Zhengzhou Bigfoot Digital Technology Co., Ltd

BF-60E2-S DTF PRINTER



■ Exquisite design ■ Fashionable appearance ■ Cost-Effective

Model	BF-60E2-S		
Print head	1600A1/3200A1(2pcs)		
Control board	Hoson board		
Resolution	2880DPI		
Speed	Draft mode	1600:7m ² /h	3200:8m ² /h
	Production mode	1600:4.6m ² /h	3200:6m ² /h
	high precision mode	1600:3.6m ² /h	3200:5m ² /h
Color	CMYK+White		
Print width	600mm		
Ink	Pigment		
Ink capacity	1.8L		
Operation Enviroment	The temperature is 15°C-30°C, and the relative humidity is 50%-75%		
Power	50HZ/60HZ/220V, Printer 1500w/10A, Oven 6500w/22A		
Operating system	Windows10 or Above		
Image format	Tiff, Jpeg, Bitmap, Eps, Pdf		
Software	Flexiprint		
Data interface	Gigabit network card		
Machine size	Printer size:1900*760*760mm(L*W*H)		
	Automatic powder shaker size:1880*1000*1190mm(L*W*H)		
Weight	Printer net weight: 145KG		
	Automatic powder shaker net weight: 285KG		

DTF PRINTER



Apply to nylon, chemical fiber, cotton, leather, swimsuit, diving suit.



T-shirt hoodie



Canvas bag



Bolster

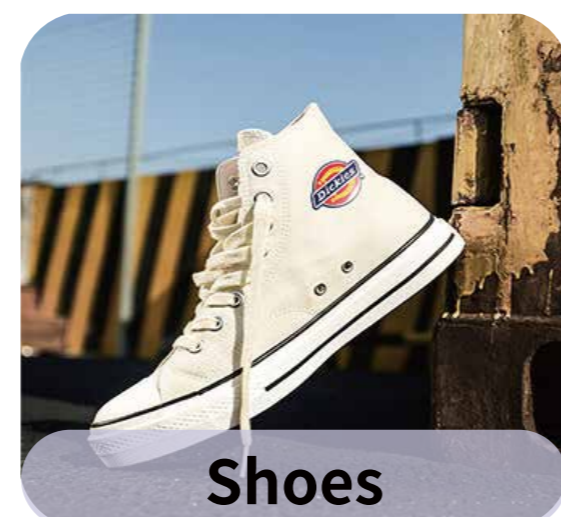

Shoes

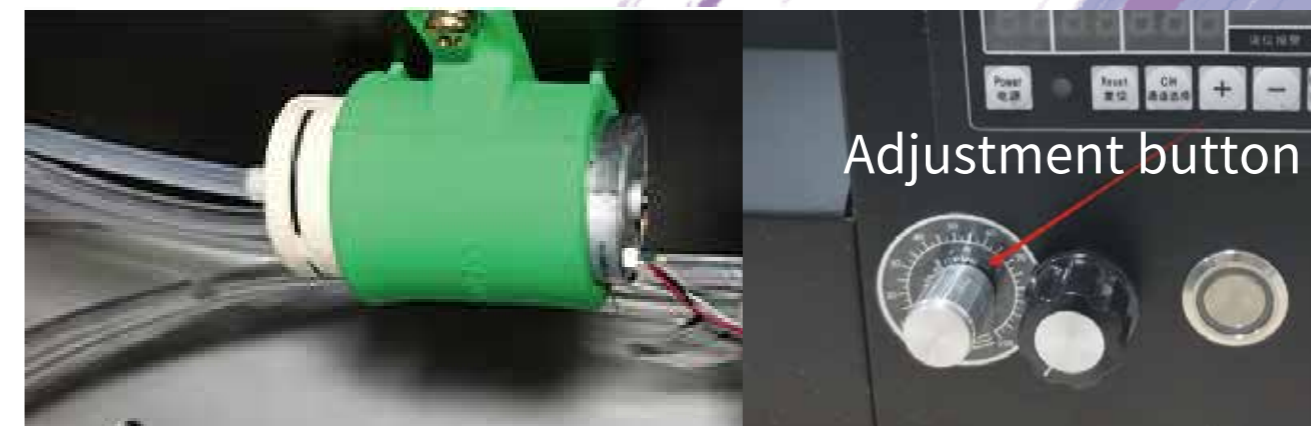

Intelligent ink-circulation system : speed adjustable auto

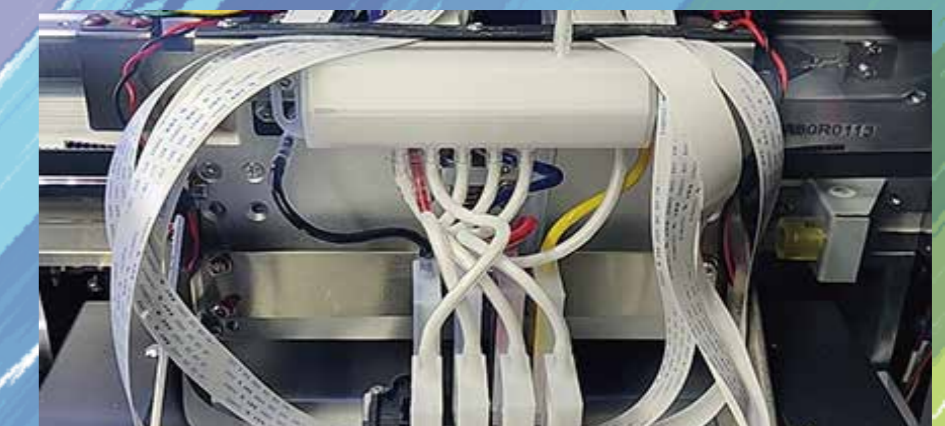

Carriage anti-collision device



White ink stirring and circulation system
Stirrer : avoid of head blocking
Ink tank alarm device



Ink tank alarm device
Monitor the ink lacking in tank.



Ink shunt : avoid of ink bubbles to print smoothly



Independent ink cartridge
stable ink supply

Powder Shaker-S

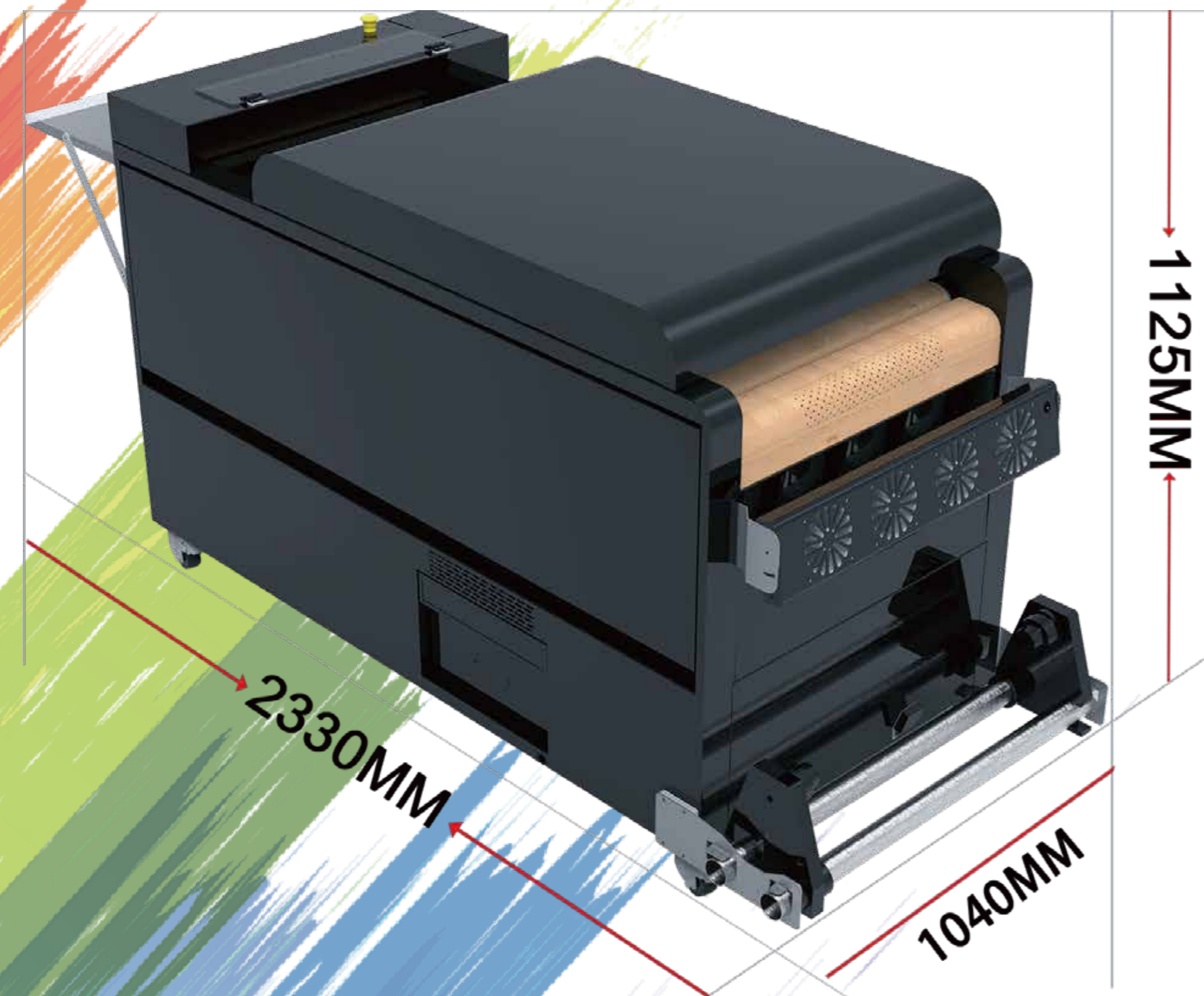

Built-in smoke filter, Oil fume separation

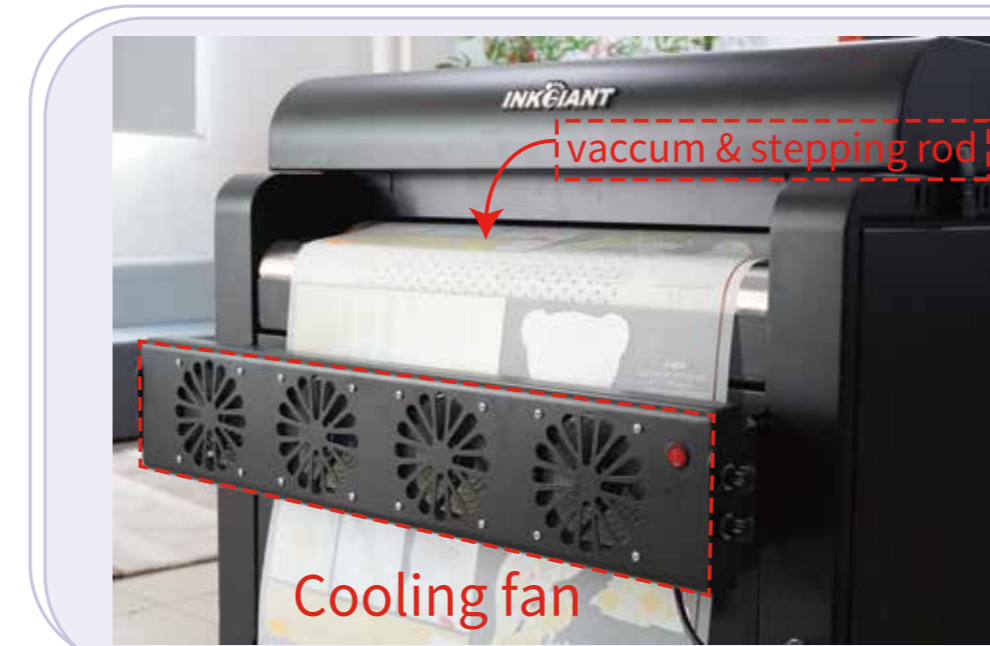

Upgraded suction function, from integration to mesh belt and suction air separation, reducing heat loss.

Lengthened drying tunnel and distributed heating tubes up and down for more even drying.

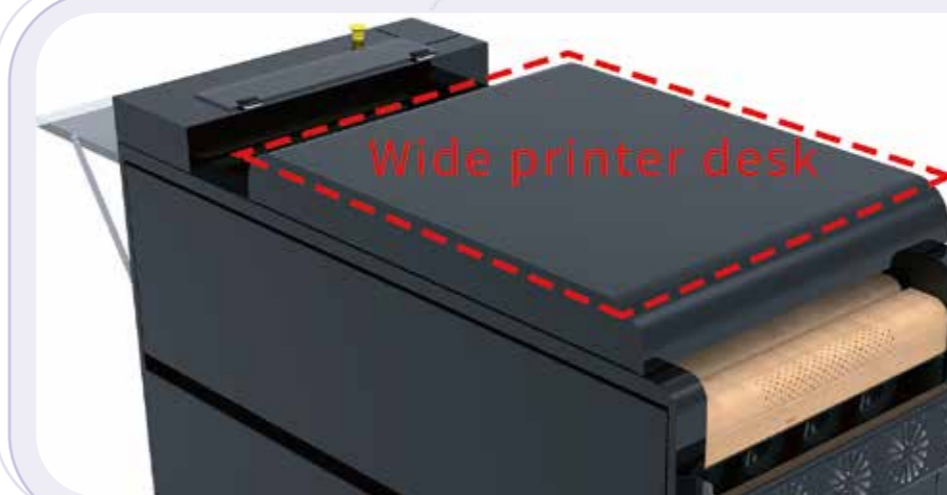
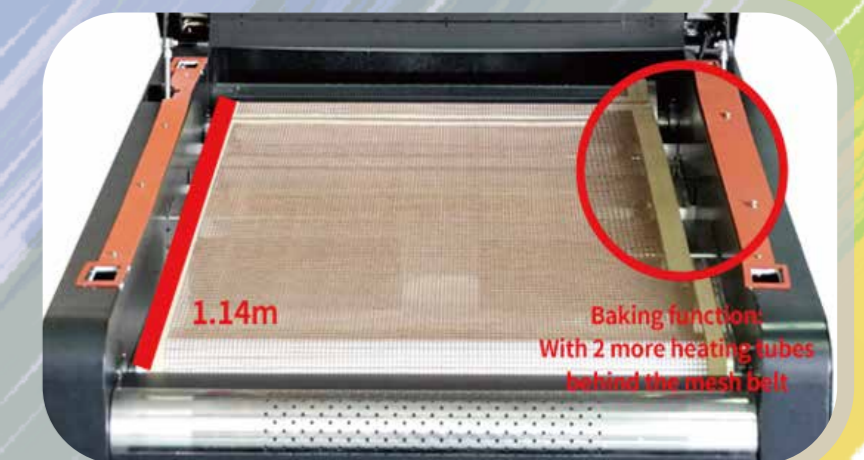

Desktop platform design of shaker, convenient operation

Integrated circuit (touch screen operation), simple circuit, digital functions



INK



Colour:	C、M、Y、K+W Cleaning soluton for DTF printer
Shelf life:	color ink 12months, white ink 9 months
Optional packing:	5Kg/bot,1KG/bot,500ml/bot,100ml/bot etc.
Storage temperature:	5°C-35°C
Recommended temperature(printing):	15°C-25°C
Humidity(printing):	45%-75%
Packing size:	460*370*240mm,1KG/BOT, 20BOT/carton
Gross weight :	23KG
Net weight:	20KG

- High whiteness, strong coverage;
- High color density and color reproduction;
- Excellent ink fluency, continuous printing for a long time without ink breakage;
- Friendly and no damage to the print head;
- Good quick-drying performance, not easy to dry in head surface, no flowing on film;
- Soft hand feeling, perfect tensile property and resilience;
- Dry/wet rubbing, washing and perspiration fastness 4-5 grade;



FILM/POWDER

Instant peel



Product name	INKGIANT DTF film
Product category	Double matte hot peel film
Size	60cm*100m/Roll
Thickness	75um

Packing size: 2rolls/carton Net weight : 14KG Gross weight : 16KG

- Easy to peel off
- Non adherent powder
- Bright color and high color transfer rate
- Excellent ink absorption performance
- No film slipping during printing
- Uniform coating and clear printing

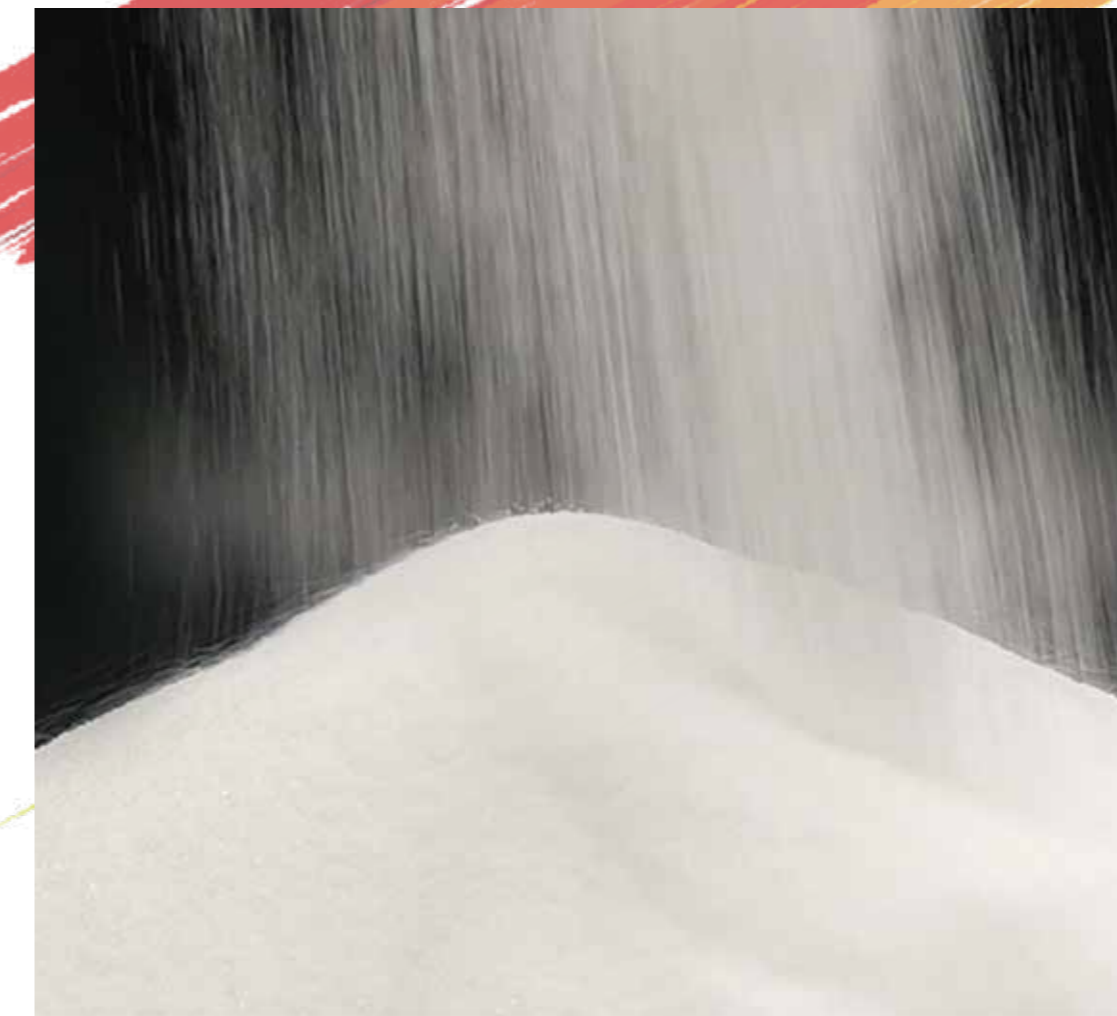

- 100% TPU, stable quality
- Good washing fastness
- Good elasticity, stretch without cracking
- Aluminum foil bag packing,
- moisture proof, safe transportation

Packing size:	1KG/BAG, 20BAG/carton
Net weight :	20KG
Gross weight :	22KG

Type	Model	Melting range	Size	Refer time (s)	Features	Fastness levels (☆ half star)	Hand feeling	Suitable fabric	Washable Washing/dry cleaning
TPU	Middle size	120°-130°	120-250	6-8s	Strong firmness, good toughness, good pulling force	★★★★☆	★★	cotton cloth, non-sublimation, polyester cloth	40°C Excellet /60°C good
	Fine size	110°-130°	80-170	6-8s	Low temperature, soft touch, smooth melting surface	★★★★	★★★★	cotton cloth, non-sublimation, polyester cloth	40°C Excellet /60°C ok
	Ultra soft	130°-140°	120-250	6-8s	Best hand feeling	★★★★	★★★★★	cotton cloth, non-sublimation, polyester cloth	40°C Excellet /60°C ok
	Anti-sub black	130°-150°	120-250	6-8s	Applied to, Sublimation Black, Fabric	★★★★	★☆☆	Sublimable black polyester fabric	40°C Excellet /60°C ok
	Anti-sub white	130°-150°	120-250	6-8s	Applied in, Sublimation fabric	★★★★	★☆☆	Sublimable polvester fabric (unlimited color)	40°C Excellet /60°C ok

Heat press machine

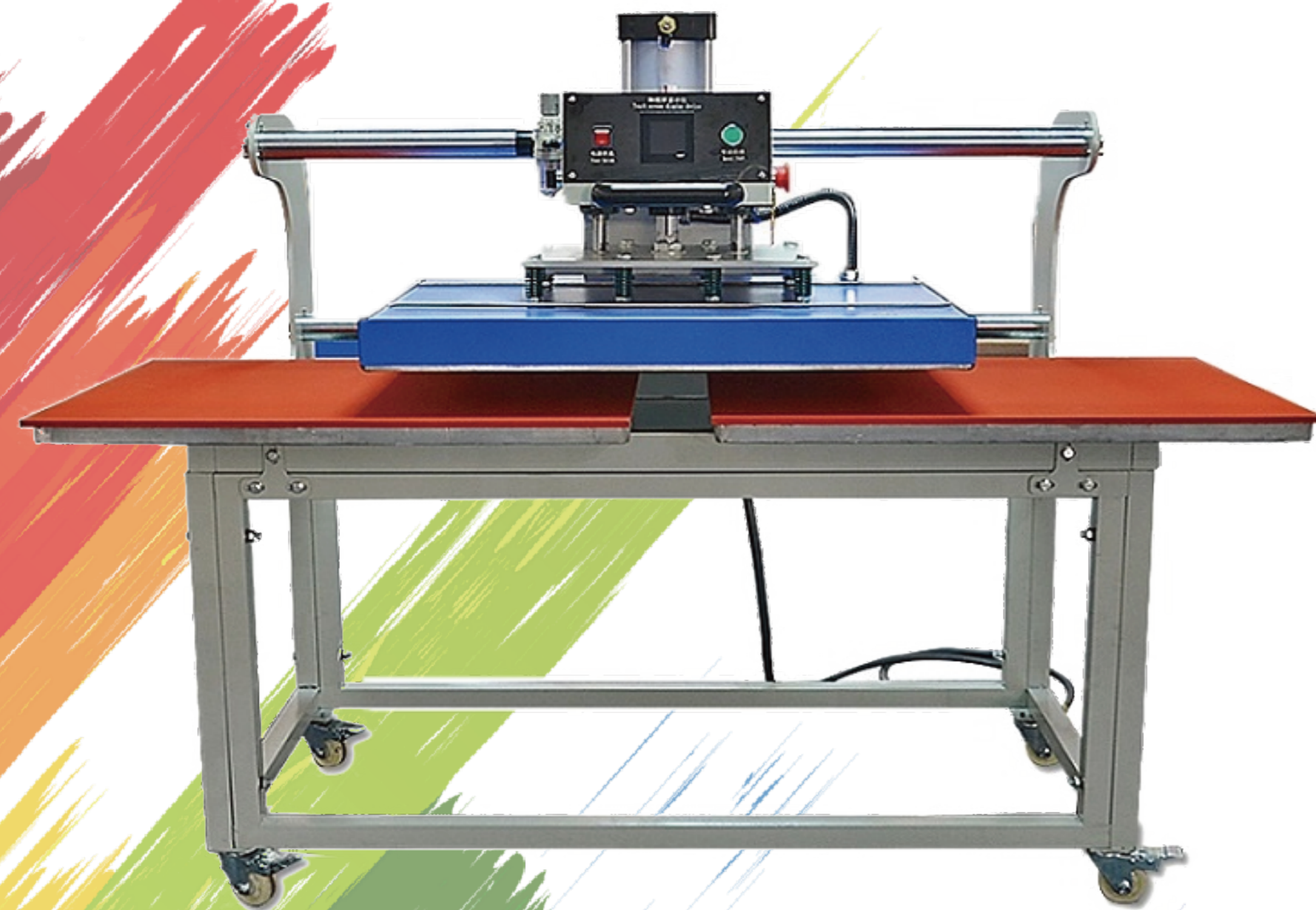

Horizontal plate up slide pneumatic double station heat press machine

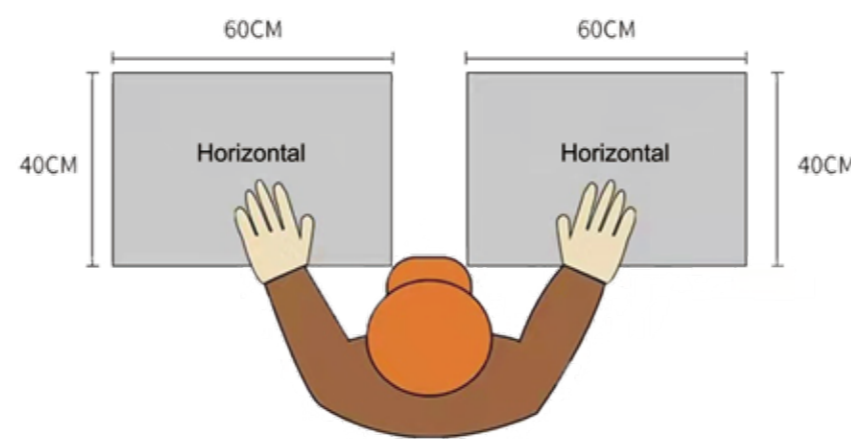

Facades display

Size:	60*40CM
Power:	3.8KW
Package size:	137*80*70
Gross weight:	170kg

size (cm)	Voltage (V)	Power (KW)	Time rang (Sec)	Temperature (°C)	Working pressure (kg/cm2)	Packaging (cm)
38*38	220	2.2	0-999	0-399	0-8	88*75*60
40*50	220	3	0-999	0-399	0-8	116*73*60
40*60	220/380	3.7	0-999	0-399	0-8	137*75*60
50*60	220/380	3.8	0-999	0-399	0-8	136*83*62
50*70	220/380	4	0-999	0-399	0-8	160*90*60
60*80	220/380	6	0-999	0-399	0-8	175*90*62
70*90	220/380	6	0-999	0-399	0-8	175*90*62
80*100	220/380	9	0-999	0-399	0-8	175*90*62



Vertical up slide pneumatic double station heat press machine

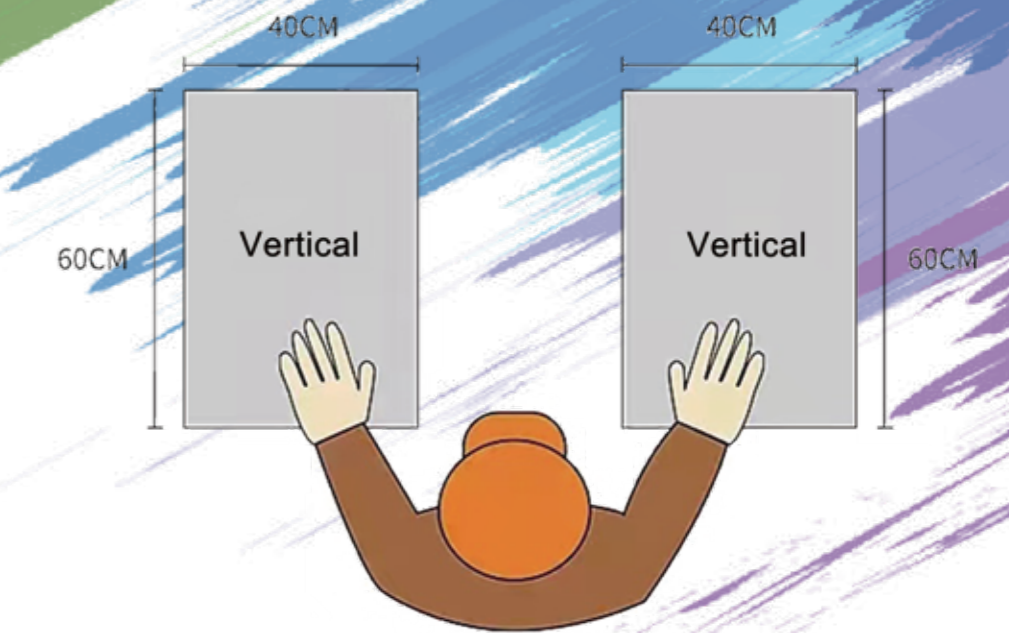

Facades display

Size:	40*60CM
Power:	3.8KW
Package size:	103*90*78
Gross weight:	170kg

- Digital control meter makes data input much easier and control time and temperature precision.
- Built-in counter to record production capacity.
- Adopt brand electronic components: F.R.L, relay, switch, air cylinder etc.
- Air pressure can be adjusted according to material thickness.
- 100x125mm powerful cylinder to generate even and stable pressure.
- 2 stainless rod Dia.50mm and 30mm to make machine running very stable and smooth.
- U shaped Heating elements was casted in aluminum to provide even temperature.
- Equipped with two infrared ray to help position article (optional).

Operation process



01 Import the processed pictures into the computer



02 Print with printer



03

Sprinkle the powder and shake the powder into the drying tunnel to melt it



04

Use Heat press machine pressing

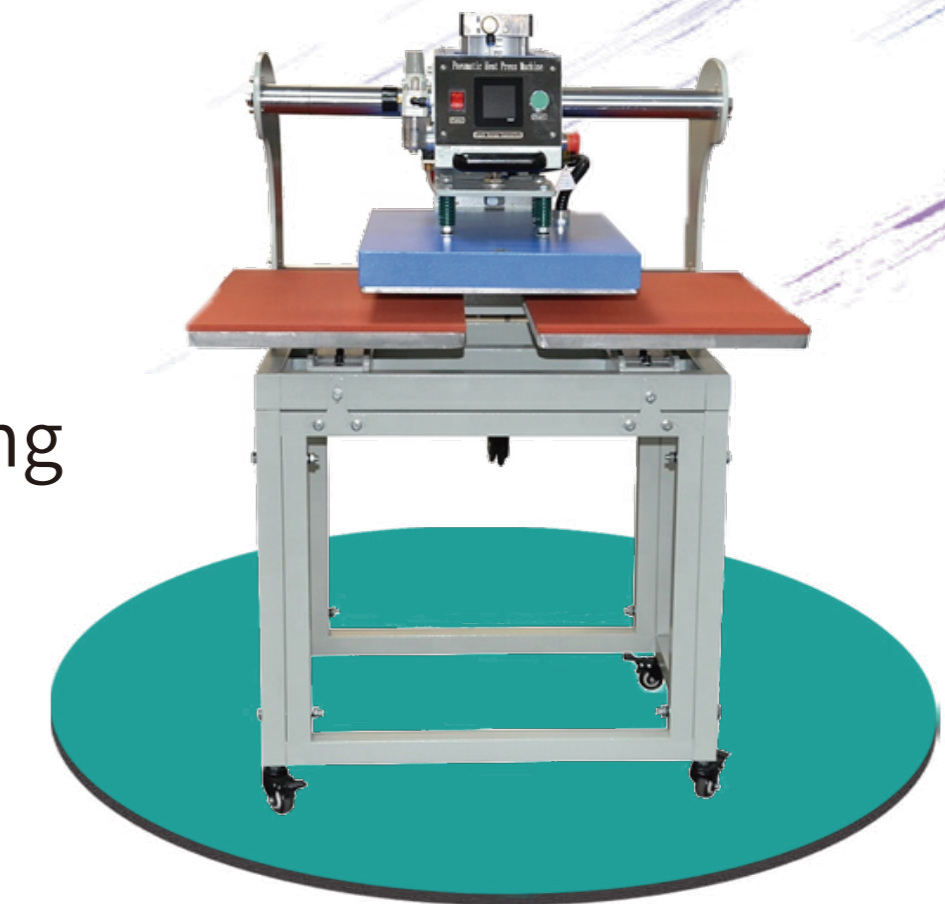

05

No need to wait to tear off the film, OS hot peel



06

Finished product display