



**Ultrasonic Hardness Tester  
SU-300  
Operation Manual**

**Sinowon Innovation Metrology Manufacture Limited**  
**[www.sinowon.com](http://www.sinowon.com)**

# Preface

## ◆Safety and Liability

This manual contains important information on the safety, usage and maintenance of instrument. Read the manual carefully before use the instrument. Keep the manual in a safe place for future reference.

## ◆Safety Instructions

 Danger: This symbol indicates a risk of serious or fatal injury in the event that certain rules of behavior are disregarded.

 Precision instrument, handle with care and avoid any serious shaking to damage internal components.

 Indenter of instrument is diamond, absolute hardness in nature, do not use it to scratch and damage precious objects.

 After a measurement, take off indenter about half second, then make a new measurement. Otherwise it can not make resonance between indenter and specimen in a short time.

 After finished use, please keep instrument in carrying case, avoid any damage by accident.

 Do not disassemble main unit and probe, otherwise no service to the instrument

 Do not use the instrument under inflammable air environment, otherwise will lead to fire or explode.

 About battery:

- Please only use the battery supplied by original manufacturer;
- Do not disassemble battery;
- When install battery, aim correctly socket to avoid wrong connection of battery negative and positive;
- Do not throw battery in fire or heating;
- Do not put battery in water or touch water;
- Do not use battery in case of deformation;
- Turn off instrument before replace battery, do not take off battery during power on status;
- Battery is installed well before leaving factory, do not make modification if no special situation.

 About recharger:

- Keep it in dry status;
- Avoid short circuit, otherwise will damage it;
- Do not touch it by wet hand, otherwise will get an electric shock;

## ◆Statement

● Without the prior written permission of the Company and its subsidiaries for all products related to the contents of this manual may be reproduced in any form spread, or in a retrieval system, or translated into other languages are stored.

● The Company reserves the right to change the specification contained hardware and software specifications without prior notice.

Every effort was made to ensure the accuracy and integrity of information contained in the instructions, if any, flaws and errors, reflected to us, we will revise the next edition, we would appreciate it!

# Content

<b>1 Introduction</b> .....	1	4.2.2 Motorized Probe Measurement Style	12
1.1. Instrument Introduction.....	1	4.2.3 Manual Probe Measurement Style.....	12
1.2. Instrument Features.....	2	4.2.4 Review/print Result.....	13
1.3. Application Range.....	2	4.2.5 Result Reading.....	13
1.4. Working Conditions.....	2	<b>5 Special Attention</b> .....	14
1.5. Packing List.....	3	<b>6 Operation Illustration</b> .....	15
<b>2 Ultrasonic Probe and Operating Principle</b> .....	4	6.1. Power On.....	15
2.1. Main Structure and operating principle .....	4	6.2. Power Off.....	15
2.2. Ultrasonic Probe.....	5	6.3. Interface and Buttons.....	15
2.2.1 Manual Probe Structure.....	5	6.3.1 Interface Illustration.....	15
2.2.2 Manual Probe Technical Data.....	5	6.3.2 Buttons Illustration.....	16
2.2.3 Motorized Probe Structure.....	6	6.4. Menu Structure.....	17
2.2.4 Motorized Probe Technical Data.	6	6.5. Test Setting.....	18
2.2.5 Indenter and Indentation.....	7	6.6. System Setting.....	19
2.3. Test stand.....	7	6.7. Memory Setting.....	20
<b>3 Technical Features</b> .....	8	6.8. Printing Setting.....	22
<b>4 Operation Precautions</b> .....	9	6.9. Calibration Steps.....	22
4.1. Preparation and Inspection.....	9	6.9.1 Calibration Selection.....	22
4.1.1 Specimen Request.....	9	6.9.2 Calibration Setting.....	22
4.1.2 Buttons Illustration.....	10	6.9.3 Optional Setting.....	24
4.1.3 System Settings.....	10	6.10. DIN50159-1-2008 Permitted Error and Repeatability.....	25
4.1.4 Test Settings.....	10	6.11. Battery.....	25
4.1.5 Calibration Selection.....	10	6.12. Data Transmission.....	25
4.2. Measurement.....	11	<b>7 Troubleshooting</b> .....	26
4.2.1 Instrument Preparation.....	11	<b>8 Maintenance</b> .....	27
		<b>9 Warranty Attention</b> .....	28
		<b>10 Storage/Transportation Attention</b> .....	28

# 1、 Introduction

## 1.1 Instrument Introduction:

Thank you for purchasing ultrasonic hardness tester, the present execute standards DIN 50159-1-2008; ASTM-A1038-2005 ; JB/T 9377-2010 and JJG-654-2013. It is a precision hardness-comparison instrument applied with ultrasonic contact impedance principle. To avoid any unnecessary damage and loss, please read this Manual carefully before operation and keep it safety for further reference.

At present, there are kinds of methods for hardness measurement, commonly used like Brinell, Rockwell, Vickers, Leeb, etc. Rockwell and Brinell with heavy loading force and big indentation, lead to serious destructive on sample surface. Vickers apply optical measurement, but only professional technicians can smoothly operate, impossible to measure hardness of heavy work piece, installed machinery and permanently assembled parts.

Ultrasonic hardness tester apply ultrasonic contact impedance method to do comparative hardness measurement for testing pieces, with advantages of high accuracy, efficiency, portable, easy operation and nondestructive measurement . As shown in fig 1-1.

Fig 1-1 Ultrasonic Hardness Tester with Test Stand

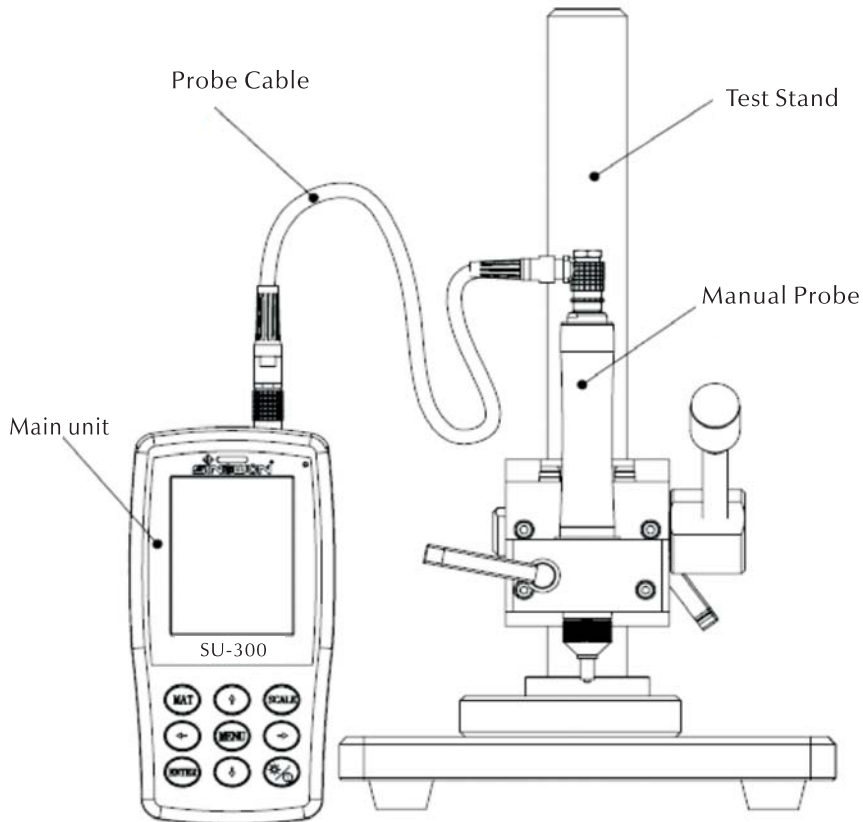

Fig 1-1

## 1.2 Instrument Features:

- Perfect Accuracy:  $\pm 3\%HV$ ,  $\pm 3\%HB$ ,  $\pm 1.5HR$ .
- Microscopic Indentation: Non destructive to specimen, only high-power microscope can observe the indentation.
- Quick Measurement : Result in 2 seconds, 60 times efficiency than bench hardness tester.
- Large LCD Display: Directly display measurement result, times count, maximum, minimal, average and conversion scale.
- Friendly Operation——Operation well after short training.
- High Performance——2 years warranty for main unit, provide long time technical support.
- Mass Storage——Save 1000 group results and 20 calibration data.
- Pre-calibration——To save 20 groups of pre-calibration data for recalling to improve measurement efficiency.
- Data export and printing——By RS232 to transfer data to computer and print.

## 1.3 Application Range:

- Hardness measurement of flange edge and gear root stamping, mold, sheet, surface hardened tooth and gear groove, and taper part;
- Hardness measurement of axis , thin-wall pipe and containert;
- Hardness measurement of wheels and turbine rotor;
- Hardness measurement of bit blade;
- Hardness measurement of welding parts;
- Measurement of certain aperture depth deep dent, convex mark greater radian, irregular plane;
- Hardness measurement of most ferrous metal ,nonferrous metals and other alloys in industrial production .

## 1.4 Working Conditions:

Working temperature:  $-10^{\circ}C \sim 40^{\circ}C$

Storage temperature:  $-20 \sim +60^{\circ}C$

Working Relative Humidity:  $\leq 85\%$

Without vibration, no corrosive medium and serious dust in the surrounding environment

## 1.5 Packing List

A) Standard Delivery of ultrasonic hardness tester SU-300					
Item	Commodity	Model	Code	Quantity	Remark
1	Instrument Panel	SU-300	882-141	1	2-Year Warranty
2	10N Motorized Probe	MP-1000	882-251	1	Consumables, No warranty
3	Probe Cable	882-801	882-801	1	Consumables, No warranty
4	Standard Hardness Block	/	/	1	Consumables, No warranty
5	USB Recharger	882-851	882-851	1	Consumables, No warranty
6	Battery	882-841	882-141	1	Consumables, No warranty
7	Screw driver	882-951	882-951	1	Consumables, No warranty
8	Carry Case	882-901	882-901	1	Consumables, No warranty
9	Warranty Card	SU-300	/	1	---
10	Quality Certificate	SU-300	/	1	---
11	Operation Manual	SU-300	/	1	---
B) Ultrasonic Hardness Tester Optional Accessories					
Item	Commodity	Model	Code	Quantity	Remark
1	Testing Stand	MU-100	882-301	/	Consumables, No warranty
2	Hardness Block	(28~35)HRC	882-611	/	Consumables, No warranty
3	Hardness Block	(38~43)HRC	882-621	/	Consumables, No warranty
4	Hardness Block	(48~53)HRC	882-631	/	Consumables, No warranty
5	Hardness Block	(58~63)HRC	882-641	/	Consumables, No warranty
6	Hardness Block	(180-300)HV5	882-651	/	Consumables, No warranty
7	Hardness Block	(300-500)HV1	882-661	/	Consumables, No warranty
8	Hardness Block	(300-500)HV5	882-671	/	Consumables, No warranty
9	Plan Support Ring	882-511	882-511	/	Consumables, No warranty
10	Small Cylinder Support Ring	882-521	882-521	/	Consumables, No warranty
11	Big Cylinder Support Ring	882-531	882-531	/	Consumables, No warranty
12	Standard Probe Protector	882-711	882-711	/	Consumables, No warranty
13	Deep-Hole Probe Protector	882-721	882-721	/	Consumables, No warranty
14	Mini Printer	882-831	882-831	/	Consumables, No warranty
15	Wireless Printer	890-831	890-831	/	Consumables, No warranty
16	Manual Probes	10N/20/50N/98N See table 2-2-2	/	/	Consumables, No warranty
17	Motorized Probes	3N/5N/8N See table 2-2-4	/	/	Consumables, No warranty
18	Statistic Software	882-381	882-381	/	---
19	Blue tooth	852-710	852-710	/	Consumables, No warranty

## 2、 Structure Illustration and Operating Principle

### 2.1 Main Structure and operating principle

Fig 2-1 Front view and back view of ultrasonic hardness tester SU-300

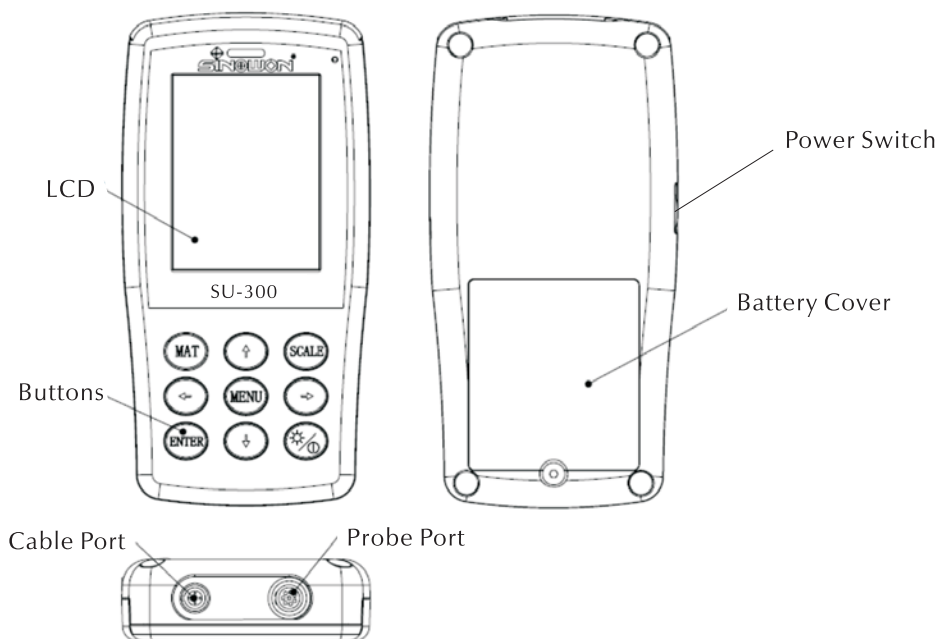

Fig 2-1

- The main unit is connected through an 8-pin data cable and ultrasonic probe, as shown in figure 1-1.
- The principle of ultrasonic hardness tester: ultrasonic contact impedance method and Young's elastic modulus of metal.
- theory equality of ultrasonic hardness testing EQ1:

$$\Delta f = f(E_{\text{eff}}, A); \quad HV = F/A$$

$\Delta f$  = Frequency Shift

$A$  = Indentation area

$E_{\text{eff}}$  = Effective elastic modulus

$HV$  = Vickers hardness value

$F$  = Force applied in the hardness test

EQ1

#### Remark:

As can be seen in Eq 1, the frequency shift not only depends on the size of the contact area but also on the elastic modulus of the materials in contact. To allow for differences in Young's modulus, the instrument has to be calibrated for different groups of materials.

After calibration, the UCI method can be applied to all materials, which have the corresponding Young's modulus.

## 2.2 Ultrasonic Probe

### 2.2.1 Types of Probe

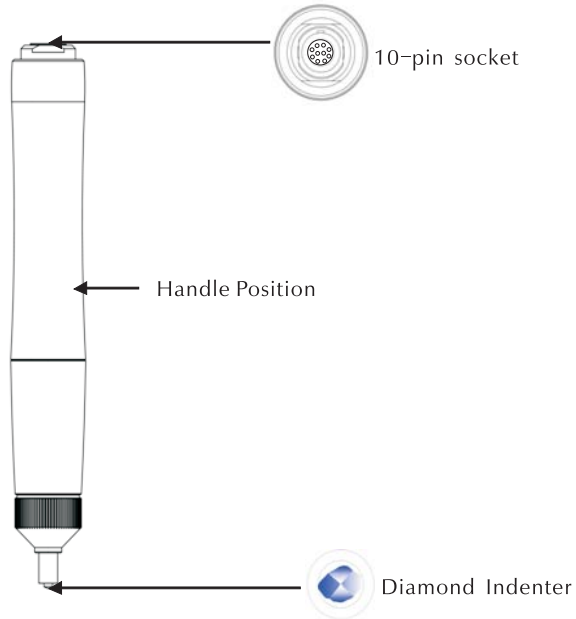

Fig 2-2-1

### 2.2.2 Manual Probe Technical Data

Table 2-2-2

Probe type	HP-1K	HP-2K	HP-5K	HP-10K
Code #	882-311	882-321	882-331	882-341
Selection	Optional	Optional	Optional	Optional
Test force	10N	20N	50N	98N
Diameter	22mm	22mm	22mm	22mm
length	154mm	154mm	154mm	154mm
Oscillating rod diameter	2.4mm	2.4mm	2.4mm	2.4mm
Roughness of specimen surface	Ra 3.2um	Ra 5um	Ra 10um	Ra 15um
Min weight of specimen	0.3kg	0.3kg	0.3kg	0.3kg
Min thickness of specimen	2mm	2mm	2mm	2mm



**2.2.3 Motorized Probe Structure**

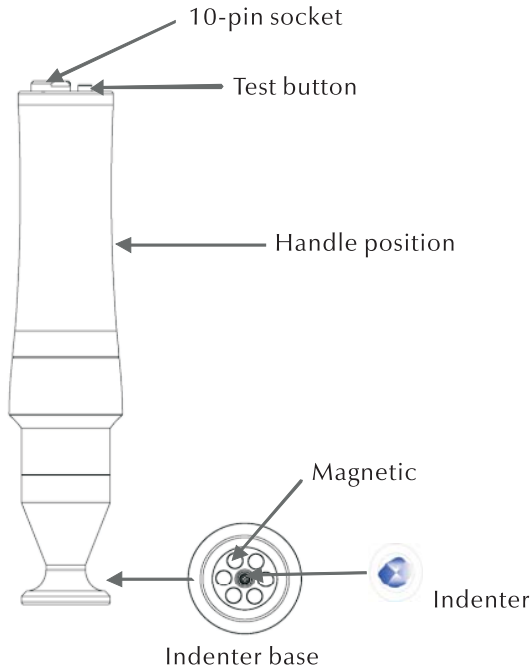

Fig 2-2-3

**▲Note:** Each probe will be photographed before leaving factory, and make sure each probe is in good condition, there is serial number of each photo, printed and send together with instrument.

**2.2.4 Motorized Probe Technical Data**

Table 2-2-4

Probe Type	MP-300	MP-500	MP-800	MP-1000
Code #	882-221	882-231	882-241	882-251
Selection	Optional	Optional	Optional	Standard
Test force	3N	5N	8N	10N
Diameter	46mm	46mm	46mm	46mm
Length	197.5mm	197.5mm	197.5mm	197.5mm
Oscillating rod diameter	3.7mm	3.7mm	3.7mm	3.7mm
Min weight of specimen	0.3kg	0.3kg	0.3kg	0.3kg
Min thickness of specimen	2mm	2mm	2mm	2mm

### 2.2.5 Motorized Probe Structure

Ultrasonic indenter is a 136° diamond indenter, showed a prism indentation on samples; the size of indentation is different based on the specimen materials. The shape of indentation is the same as Vickers and need high power microscope to observe . As shown in figure 2-3-2-1、 2-3-2-2

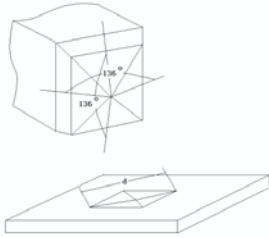

Fig 2-3-2-1

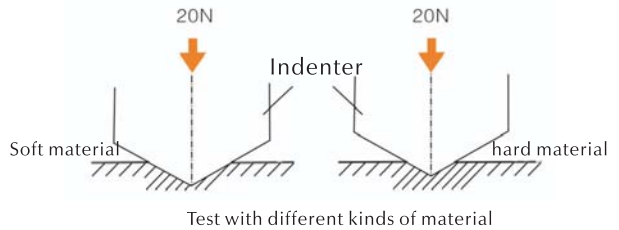

Fig 2-3-2-2

- Indentation depth (h) and dialogue length mean value (d) of ultrasonic hardness tester probes decreases along with hardness value increasing. Table 2-3-3

Table 2-3-3

Specific hardness value by different probes of ultrasonic hardness tester with its indentation depth (h, μm)						
Vickers Hardness	MP300	MP500	HP-1K	HP-2K	HP-5K	HP-10K
800HV	4	5	7	10	15	22
600HV	4	5	8	11	18	25
500HV	5	6	9	12	19	27
300HV	6	8	11	16	25	35
100HV	10	13	19	27	43	61

### 2.3 Testing stand

- In order to maximally eliminate human operation error, install ultrasonic hardness tester in testing stand MU-100, can easily obtain stable testing results.
- Testing stand MU-100 is an auxiliary device can improve calibration accuracy.

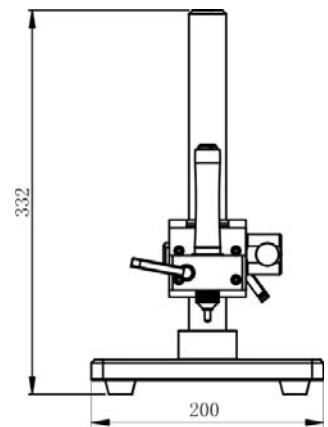

Fig 2-3

# 3、 Technical Features

## 3.1 technical data

- Measurement Ranges:  
 HRC: 20~70      HRB: 41~100      HRA: 61~85.6      HS: 34.2~97.3  
 HV: 80~1599      HB: 85~650      Tensile strength:255~2180N/mm
- LCD: 3.2" Color LCD ;
- Printing: Support blue tooth wireless printer, USB wire printer;
- Auto Sleep: Power on in 30 min without any operation will enter sleep;
- Battery: Voltage4.2V, 4800mAh rechargeable battery ;
- Recharging Time: 8 hours, at least 4 hours;
- Standby time: 12 hours;
- Conform Standard: ASTM E140-2005; DIN 18265; GB/T 1172-1999;
- Language: English, Chinese, German, etc;
- Mass Storage——Save 1000 group results and 20 calibration data;
- Test result: Can calculate average value of the specimen with uneven hardness distribution through gathering multiple-points measurement, convert to others hardness scales;
- Support hardness scales: HRC、HV、HBS、HBW、HK、HRA、HRD、HR15N、HR30N、HR45N、HS、HRF、HR15T、HR30T、HR45T、HRB;
- Support Probe: Manual probe 1N、3N、5N、8N、10N、20N、50N、100N、500N; Motorized probe 1N、3N、5N、8N、10N、20N、50N、100N;
- Measuring Directions: support 360° ( As long as the probe is perpendicular to the specimen then can be measured, and angle can be  $90^{\circ}\pm 5^{\circ}$  between indenter and specimen surface ) ;
- Recharging: INPUT:AC220V/50Hz、110V/60Hz; OUTPUT:DC5V/1A;
- Data export and printing——By RS232 to transfer data to computer and printer。

## 3.2 Weight and dimension

- Main unit dimension and weight: 162×81×31mm; 0.5kg。
- Packing dimension and weight : 350×450×150mm; Weight (Standard delivery): 5kg。

# 4、 Operation Precautions

## 4.1 Preparation and Inspection

### 4.1.1 Specimen Request

#### ●Minimum Thickness

Ultrasonic hardness tester uses Vickers diamond indenter, so the calculation formula of Vickers hardness tester is still applicable in ultrasonic hardness tester. Thin coatings or surface layers on bulk material must have a minimum thickness (t).

1)、 Penetration depth of the Vickers diamond pyramid for a certain hardness (in HV) and test load (in N) is shown in EQ2

$$h=0.062\sqrt{\frac{F}{HV}} \quad (4-1-1)$$

h:mm, Test load F:N

Mini thickness of at least on 10 times of the indentation depth of indenter used

$$t\geq 10h \quad (4-1-2)$$

From (4-1-1) and (4-1-2) , we can get

$$\text{Mini thickness } t\approx 0.62\sqrt{\frac{F}{HV}} \quad (4-1-3)$$

T: mm; F:N

From formula 4-1-3, we can get below table for minimal thickness (Table 4-1-0)

Specific hardness value (HV) with different probes request minimal thickness as follows				
	HP-1K	HP-2K	HP-5K	HP-10K
800HV	69	100	150	220
600HV	79	110	180	250
300HV	112	160	250	350

Fig. 4-7 Specimen thickness, testing force and hardness value

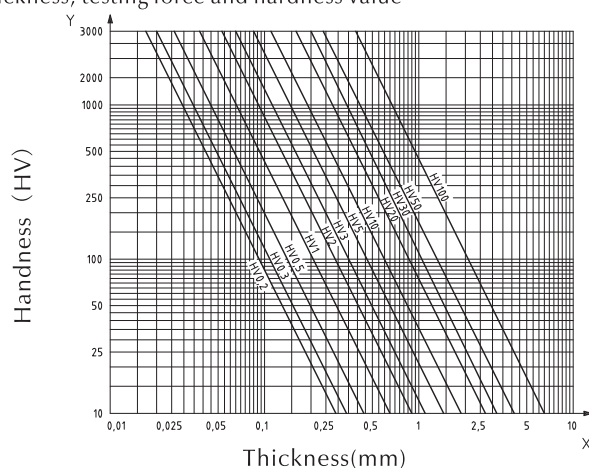

F4.7 Specimen thickness, testing force and hardness value (HV0.2~HV100)

**▲Note:** According to Ultrasonic Contact Impedance Method (UCI Method), probe must contact with test piece then get resonating, and get hardness value, so the mini thickness of Vickers hardness value only apply on big testing pieces or surface.

2) From above analysis, all the probes request coating layer or surface layer less than 1mm, but to small pieces, when thickness less than 15mm, the hardness value will change if resonance.

Most vibration is the elastic oscillation, we can take some actions to restrain. Put the peice on big metal, rubber and oil can restrin elastic wave, but recommend least 2-3mm, size not less than 5×5mm.

**●Surface roughness of test piece**

The applied test force (that is, the selected UCI probe) must not only match the application but also the surface quality and roughness of the material. While smooth, homogeneous surfaces can be tested with low test loads, rougher and coarse-grained surfaces require test loads as high as possible. However, the surface must always be free of any impurities (oil, dust, etc.) and rust.

The surface roughness should not exceed '30 % of the penetration depth (Ra # 0.3 3 h) with:

Probe	HP-1K(10N)	HP-2K(20N)	HP-5K(50N)	HP-10K(98N)
Ra	Ra < 2.5 μ m	Ra < 5 μ m	Ra < 10 μ m	Ra < 15 μ m

Fig 4-1-1

**●Weight of test piece and testing method as fig4-1-2**

Weight	> 300g	100~300g	10~100g
Auxiliary	Directly test	Support rings	Coupling

Fig 4-1-2

- Test pieces with curved surfaces may be tested on either the convex or concave surfaces providing that the radius of curvature of the specimens is matched to the appropriate probe and probe attachment in order to ensure a perpendicular positioning of the probe.
- When the specimen is plate, long rod or curved pieces, even if the weight and thickness are enough, still will cause the specimen's instability deformation, finally lead to measure a wrong data. So must strengthen or support for the back part of the test point. As for deep hole with a certain aperture, it will be measured conveniently as long as groove can change the deep-hole probe protective cap.

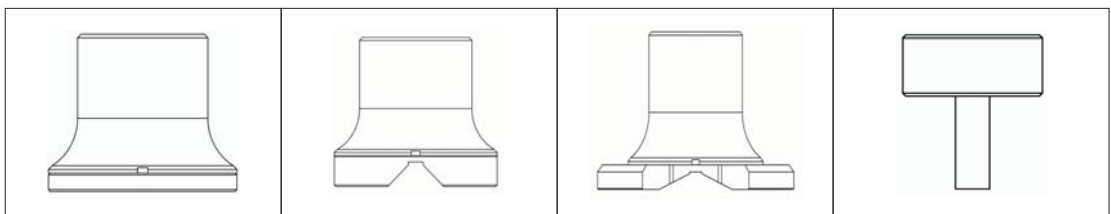

Plan support ring (#882-511)

Small cylinder support ring (#882-521)

Big cylinder support ring (#882-531)

Deep hole probe protector (#882-721)

Fig 4-1-1

**4.1.2 Buttons Illustration**

Details see part 6.2.3

**4.1.3 System Settings**

Details see part 6.6

**4.1.4 Test Settings**

Details see part 6.5

**4.1.5 Calibration Selection**

Details see part 6.9

## 4.2 Measurement

### 4.2.1 Instrument Preparation

Connected the bending end plug of 10-pin data cable with the 10pin socket of probe, aligned with the groove's positions then gently insert . Hearing "click" sound that has been inserted in place as shown in figure 4-2-1-1; At the same time ,connected the other side of 10pin data cable with the 10pin socket of main unit of ultrasonic hardness tester. aligned with the groove's positions and then gently insert .Hearing "click" sound that has been inserted in place as shown in figure 4-2-1-2.

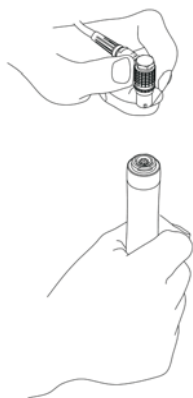

Fig 4-2-1-1



Fig 4-2-1-2

- Power on, then see if “MP:10N” shows in the second row of LCD, if yes, means motorized probe 10N was connected well (Manual probe show HP:20N). While if show Error in red, means probe not connected.
- ◆ There are two possibilities for no connect of probe. 1, not connect probe with main unit, 2, connected wrong probe.
- ◆ Solution: make sure probe connected with main unit, and check if probe setting is right, enter menu–test setting–probe option.
- Then go into the main interface, press [SCALE] button to select measurement scale and then press ETR button, after that we can start measurement.
- Before the formal measurement of specimen, please inspect the instrument matching with the special ultrasonic hardness blocks, just to check the permitted error and repeatability of the measured number. ( in the vertical, pressure to the hardness block 5 times, get the average values compared with the number of hardness block, check whether the error and repeatability have exceed the standard or not . the user could calibrate by themselves if exceeding.
- SU–300 supports manual probe and motorized probe, before measurement, we need setup probe type (see part 6.6)



Fig 4-2-2-2 Single mode



Fig 4-2-2-3 Average Mode

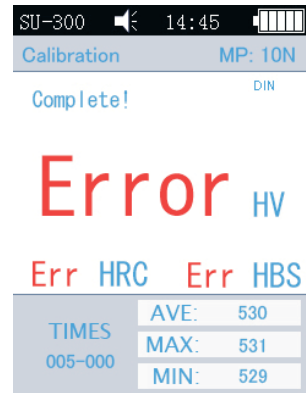

Fig 4-2-2-4 Error Interface

**4.2.2 Motorized Probe Measurement Style**

- Enter **【 System Setting 】** – **【 Test Setting 】** – **【 Probe Select 】** – Click Motorized Probe ( See part 6.6 ).
- After probe connected well, make specimen and probe vertically contact, then press red test button on top of probe, probe will auto test, after 2 seconds, main unit will make a sound “beep”, means loading is finished, on LCD we can see the status changes “loading...”-“testing...”-“unloading...”. Test results will show on LCD after unloading.
- ◆ **Average Test Mode:** After hear “beep”, LCD shows “Ready” means first measurement is finished, then repeat about step 4 time, after the fifth measurement done, main unit will make two sound, left up corner shows “Complete”, means this group total 5 measurements was done. Results show in Fig 4-2-2-3. (005-000 is the average value of group test). Test result was saved in **【 Storage Setting 】** → **【 Review Data 】**, by press **【 ↑ 】** and **【 ↓ 】** to see all the test results.
- ◆ **Single Test Mode:** After hear “beep”, LCD shows “Ready” means first measurement is finished. Test result was saved in **【 Storage Setting 】** → **【 Review Data 】**, by press **【 ↑ 】** and **【 ↓ 】** to see all the test results.
- ▲ **Remark:** For no magnetic specimen, we have to hold the probe to make measurement more accurate.

**4.2.3 Manual Probe Measurement Style**

- Enter **【 System Setting 】** – **【 Test Setting 】** – **【 Probe Select 】** – Click Manual Probe ( See part 6.6 ).
- Hold the middle part of probe, keep the probe and specimen surface in vertical position, then evenly & downward press the probe vertically until the probe protective cap against the specimen, as shown in figure 4-2-2-1, hold this movement around 2 seconds, then you will hear a “beep” sound, indicating that the probe and the measured object coupling end, and the measuring value shows on display.
- ◆ **Average Test Mode:** After hear “beep”, LCD shows “Ready” means first measurement is finished, then repeat about step 4 time, after the fifth measurement done, main unit will make two sound, left up corner shows “Complete”, means this group total 5 measurements was done. Results show in Fig 4-2-2-3. (005-000 is the average value of group test). Test result was saved in **【 Storage Setting 】** → **【 Review Data 】**, by press **【 ↑ 】** and **【 ↓ 】** to see all the test results.

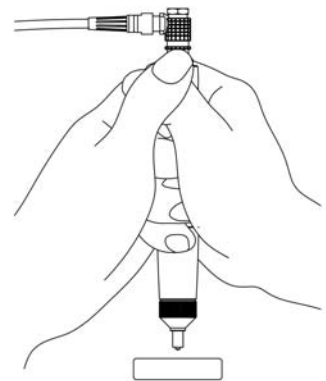

Fig 4-2-2-1

◆Single Test Mode: After hear “beep”, LCD shows “Ready” means first measurement is finished. Test result was saved in 【Storage Setting】 → 【Review Data】 , by press 【 ↑ 】 and 【 ↓ 】 to see all the test results.

▲If wrong operation, it will show Error interface, Fig4-2-2-3.

▲If exceeds measuring range, it will show ↓ or ↑ .

▲Please read part 7 if occur above problem.

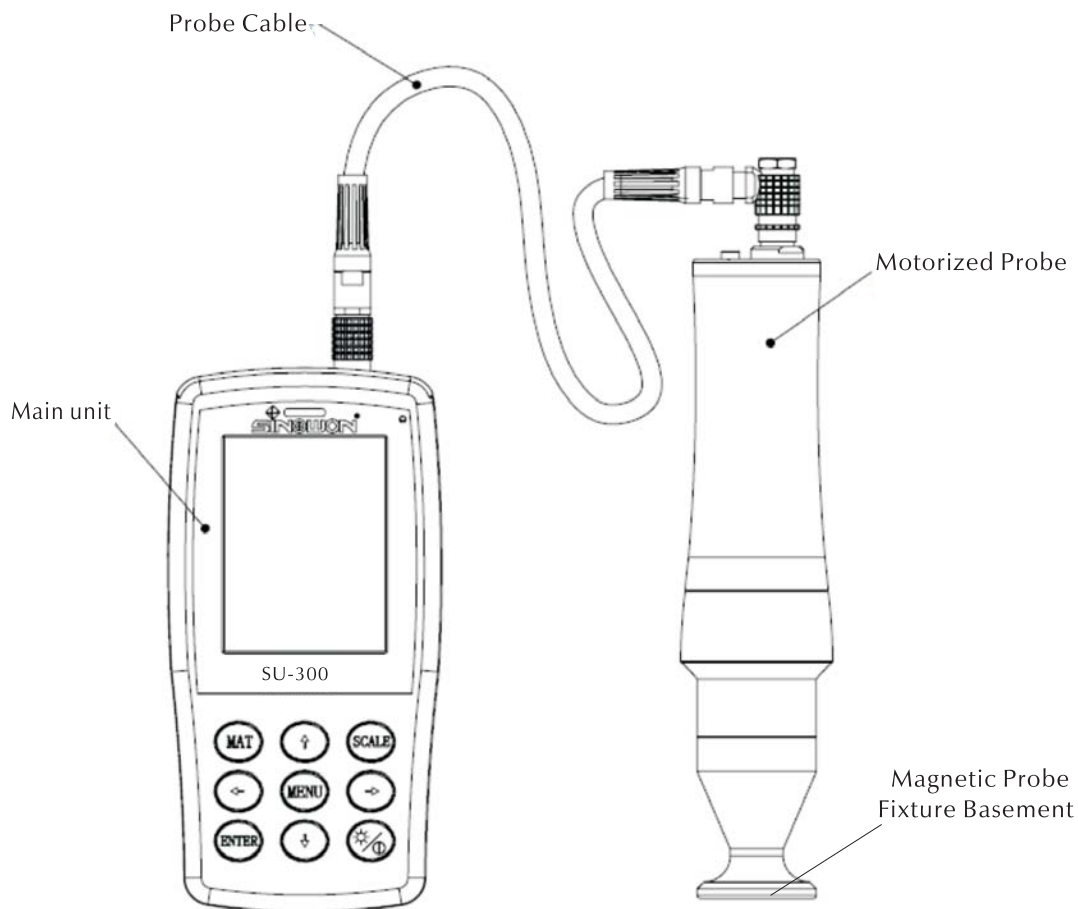

Fig 4-2-3-1

#### 4.2.4 Review/print Result

See part 6.7 and 6.8 for details

#### 4.2.5 Result Reading

SU-300 supports hardness scales HRC、HV、HBS、HBW、HK、HRA、HRD、HR15N、HR30N、HR45N、HS、HRF、HR15T、HR30T、HR45T、HRB、MPA.

The numerical hardness value shall be followed by the symbol for the UCI test, HV(UCI) in the case of a Vickers reading with a suffix number denoting the test force in kgf. Example: 446 HV(UCI) 10 = UCI hardness number of 466 under a force of 10 kgf. If numerical hardness values are presented in other scales by calibration they should analogously be reported as 45 HRC(UCI) or 220 HBW(UCI) etc.



## 5、 Special Attention

- Before the replacement of different probe, please turn off the power of main unit then operate .
- keep probe and specimen Vertically Contacted .
- If long time no use, please recharge before reusing .
- Press MENU button to stop if measurement don't want to be continued. If you would like to restart measurement, you could press ETR button.
- When connected the probe with the data cable or main unit with data cable , must operate according to the previous steps, aligned with the groove's positions and then gently insert, otherwise the internal pin of plug connected with data line may be crooked and damage.
- Five measurement taken in an area of approximately 645mm<sup>2</sup> shall constitute one test. If the material being tested is considered to be inhomogeneous, then measurements or more shall be made to constitute one test.
- Because the ultrasonic hardness probe is precision components, should pay special attention to protection during measurement, do not hit any part of the probe. The operation method is correct or not will directly affect the measuring accuracy. The correct method is, use two hands to fix the probe, pressure is applied to the direction and object vertically, To avoid the change of pressure, please make sure to keep your hand not moving and shaking. In order to avoid scratching the specimen by probe and the probe abrasion by itself, you must lift the probe vertically after one measurement time.
- Temperature—The temperature of the test piece may affect the results of the UCI hardness test. However, if the probe is exposed to elevated temperature for only the time of measurement, measurements are possible at temperatures higher than room temperature, without influencing the performance of the UCI instrument.

# 6、 Operation Illustration

## 6.1 Power On

- Upwards slide power switch, display shows as Fig 6-1, then enter main interface.

## 6.2 Power Off

- Power off : Downwards slide power switch.
- Sleep: When power on, long press button  to enter sleep, press again back to working interface.

## 6.3 Interface and Buttons

### 6.3.1 Interface Illustration

The interface shows status display, model information, the information of material calibration group, test result, hardness conversion shown in figure 6-3



Fig 6-1

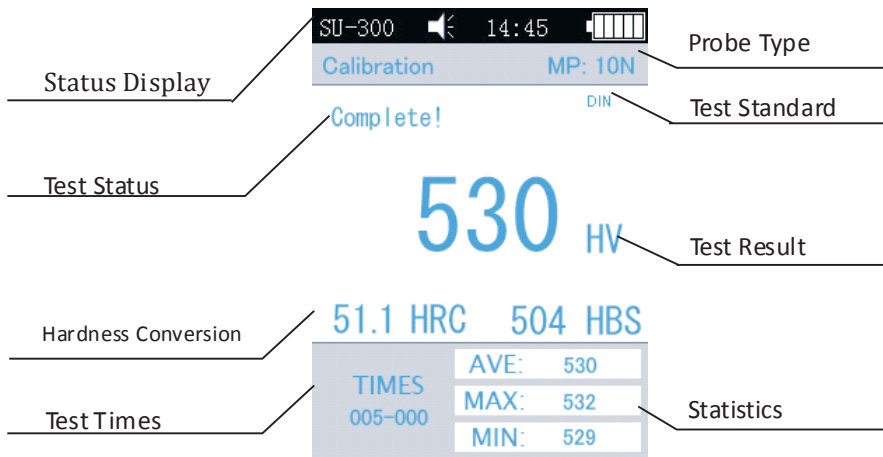



Fig 6-3

- Status Display-- Model, buzzer , system time, battery .
- Probe——Calibration Group Name, MP:10N means motorized probe with test force 10N.
- Test Info——Show test status “Loading...”, “Testing...”, “Unloading...”, “Ready!”, “Complete!”.
- Test Standard——show standard ASTM、DIN 18265、GB/T 1172.
- Test result ——to display hardness value.
- Hardness conversion——display hardness conversion result .
- Test times-- Group test mode display Times : 005-000, means after 5 measurement than calculate average value,(single mode means only test once) .
- Statistic——To show Max value, Min value, Average value.

### 6.3.2 Buttons Illustration

- **【 MAT 】** ——Start calibration in calibration interface; select calibration group in calibration selection interface; Short cut of calibration selection interface in main interface; as selected printing data in printing interface.
- **【 SCALE 】** ——Select hardness scale in main interface; positioning measurement data in displaying interface; in delete interface, delete selected data.
- **【 MENU 】** ——For confirmation in main interface and calibration interface; In others interface, used as back to previous menu and quit.
- **【 ETR 】** ——Start measurement in main interface; used as confirmation in others interface.
- **【 ↑ 】** ——Upward direction and increasing .
- **【 ↓ 】** ——Downward direction and decreasing .
- **【 → 】** ——Move right, adjust contrast of screen-lighter .
- **【 ← 】** ——Move left, adjust contrast of screen-darker .
-  ——Long press to enter sleep .

### 6.4 Menu Structure

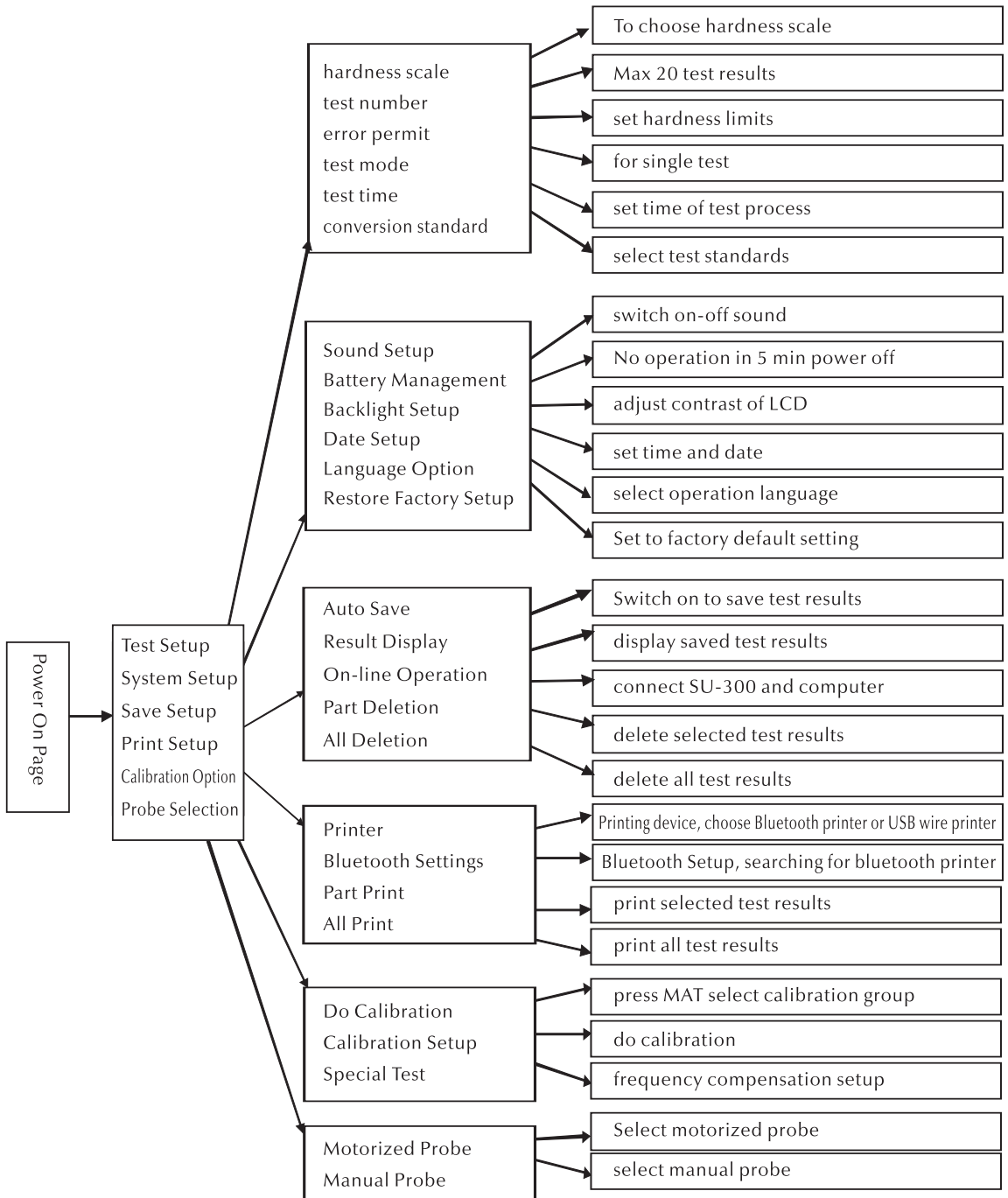

## 6.5 Test Settings



Fig 6-4-1



Fig 6-4-2

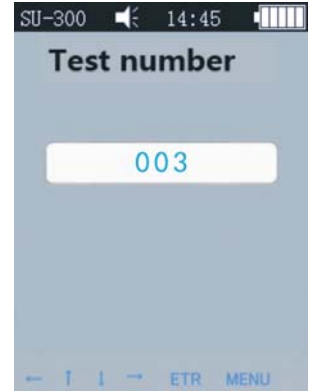

Fig 6-4-3

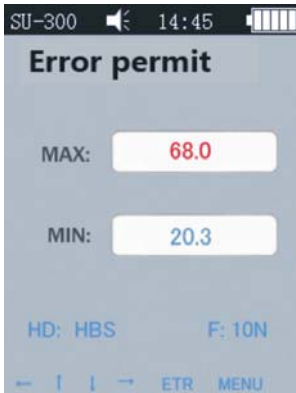

Fig 6-4-4



Fig 6-4-5

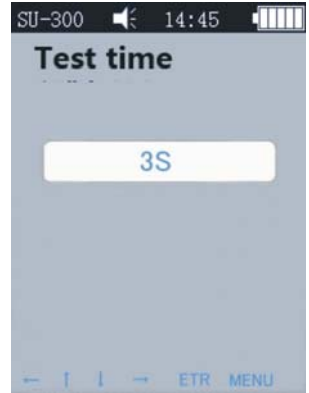

Fig 6-4-6

● Press **[MENU]** enter Test Setup, Select hardness scale, press **[ETR]**.

- a) **Hardness Scale**—In Fig 6-4-4, press **[↑]** **[↓]** choose hardness scales, then press **[ETR]** confirm; also can get correct scales by press button **[SCALE]**.
  - 1) Operators can show commonly used hardness scales or hide some seldom use hardness scales.
  - 2) Set steps: enter "Restore Factory Setup", press **[ETR]** enter edit page (See Fig 6-4-17), enter password "888881", use direction button to choose password, then press **[MAT]** to confirm, press **[Scale]** to delete, press **[ETR]** once finished all password, then back to password interface. At this time, password has been entered, see Fig 6-4-18, press **[MAT]** to confirm, then system will display all scales, users can click and press **[ETR]**.
- b) **Test Number**—Press **[←]** **[↓]** to increase or **[→]** **[↑]** to decrease test time, **[ETR]** to confirm, and **[MENU]** to exit.
- c) **Error Permit**—In Single mode to set permitted error range, press button **[↑]** **[↓]** to select MAX/MIN, then press **[ETR]** enter edit interface to set MAX and MIN value. While if test result exceeds limited range, will show Failed in red, otherwise show pass, this is only for single mode, see Fig4-2-2-2.
- d) **Test Mode**—by press **[↑]** **[↓]** to select single mode or Average mode, press **[ETR]** to confirm. See Fig 4-2-2-2 and Fig 4-2-2-3.

- d) **Test Mode**——by press 【 ↑ 】 【 ↓ 】 to select single mode or Average mode, press [ETR] to confirm. See Fig 4-2-2-2 and Fig 4-2-2-3.
- e) **Test Time** —— Press 【 ← 】 【 ↓ 】 【 → 】 【 ↑ 】 to set test time, then press [ETR] confirm and [MENU] exit. See Fig6-4-6, the value is small, the speed is fast. Generally advise if big test force, set higher value.
- f) **Conversion Standard**——there are 3 standards 1).ASTM E 140-2005; 2.)DIN 18265;3).GB/T1172-1999;

## 6.6 System Setting



Fig 6-4-10



Fig 6-4-11



Fig 6-4-12



Fig 6-4-13

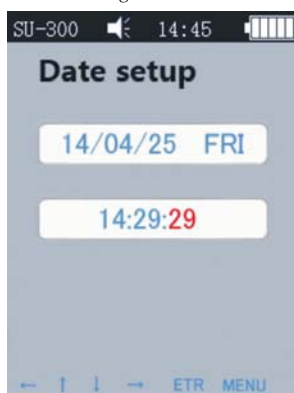

Fig 6-4-14



Fig 6-4-15

- a) **Sound**——By press 【 ↑ 】 【 ↓ 】 to ON/OFF voice, in OFF condition, only off press voice, others operation voice is normal, see Fig 6-4-11
- b) **Battery Manage**——By press 【 ↑ 】 【 ↓ 】 to ON/OFF, in ON condition without any operation in 5min, instrument will auto power off, same circumstance when in recharging, it is normal. If in OFF condition, the instrument will be always in standby time until use off the battery, we have to manually turn off. This mode is used in outer power supply, see Fig 6-4-12
- c) **Backlight Setup**——by press 【 ← 】 【 ↓ 】 【 → 】 【 ↑ 】 to adjust contrast of screen, press [ETR] to confirm setup, or press 【 ETR 】 and 【 MENU 】 quit.  
**▲Remark:** in others interface, by press 【 ← 】 【 → 】 also can adjust backlight.
- d) **Date Setting**——Press 【 ↑ 】 【 ↓ 】 switch, press 【 ← 】 【 → 】 setting, see Fig 6-4-14
- e) **Language option**——By press 【 ↑ 】 【 ↓ 】 to choose language (Chinese, English, or others), see Fig 6-4-15, press [MENU] to quit.

f) Restore Factory Setup——in Fig 6-4-16, press **[ETR]** enter password “888888”, show as Fig 6-4-17, press **[ETR]** to quit, in Fig 6-4-18, press **[MAT]** system restore factory setup.

▲Restore Factory Setup will clean calibration data, test settings, system settings, testing results, without special situation, please do not use this function.



Fig 6-4-16



Fig 6-4-17

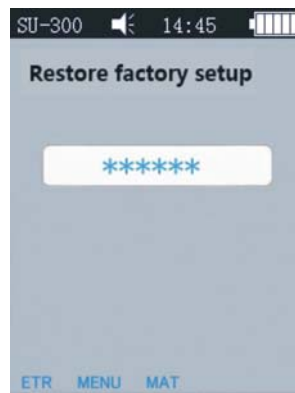

Fig 6-4-18

## 6.7 Memory Setting



Fig 6-7-1



Fig 6-7-2

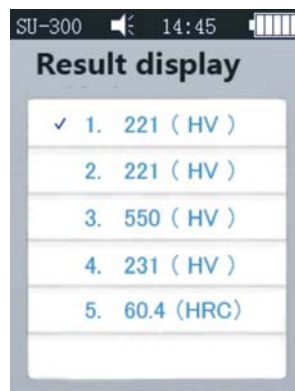

Fig 6-7-3

Press **[↑]** **[↓]** to switch and select, press **[ETR]** enter submenu, Press **[MENU]** quit.

a) **Auto Save**——By press **[↑]** **[↓]** to switch ON/OFF; In ON status, measuring data will be save automatically.

Fig.6-7-2 。

b) **Result Display**——Enter interface ( Fig 6-7-3 ) by following 2 methods:

1.Main interface press **[↑]** **[↓]**;

2.Main interface press **[MANU]** enter system menu-memory setup-result display.

◆In Fig 6-7-3, 3 methods to review:

1.Press **[↑]** **[↓]** view sequentially;

2.Press **[←]** **[→]** turn pages;

3.Press **[MAT]** view positioning: Press **[MAT]** enter edit interface. 1.Press **[↑]** **[→]** **[↓]** **[←]**;

2.Press **[ETR]** to edit groups, then press **[MAT]** positioning to specific group.

◆Press [ETR] to see details of test results, total 3 pages, from left to right is P1 (Fig 6-7-6)/ P2 (Fig 6-7-7); Average mode, 1 page (Fig 6-7-8).

▲Remark: Probe: “MP”= Motorized Probe, “HP”= Manual Probe



Fig 6-7-4

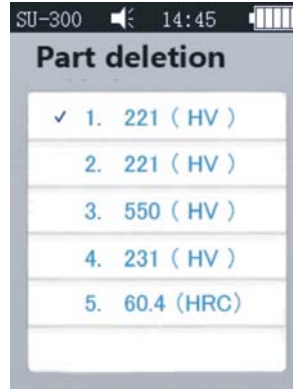

Fig 6-7-5

<b>Material</b>	— Calibration Name
<b>MP</b>	— Probe Info
<b>CNT</b>	— Test Number
<b>HD</b>	— Hardness Scale
<b>AVE</b>	— Average Value
<b>MAX</b>	— Max Value
<b>MIN</b>	— Min Value

Fig 6-7-6

<b>F+</b>	— MAX-AVE
<b>F-</b>	— AVE-MIN
<b>S</b>	— Permitted Error
<b>S/AVE</b>	— Permitted Error/Average
<b>RE</b>	— (MAX-MIN)/AVE
<b>Date</b>	— Test Date
<b>Time</b>	— Test Time

Fig 6-7-7

<b>Material</b>	— Calibration Name
<b>MP</b>	— Probe Info
<b>HD</b>	— Hardness Scale
<b>Value</b>	— Test result
<b>Date</b>	— Test Date
<b>Time</b>	— Test Time

Fig 6-7-8

c)On-line Operation——By press [↑] [↓] switch on-off on-line operation, see Fig6-7-4; The test results were sent to computer through hyper terminal, details of hyper terminal see part 6.12.

d)Partial Deletion——delete test results, Press [ETR] to select data, Press [SCALE] to delete them, Fig 6-7-5.

e>Delete All——Press [ETR] enter printing page, system display dialog box, press [ETR] to delete all the test results.



## 6.8 Printing Setting

- **Printing Device**——Press [ ETR ] enter page, select printing mode: Bluetooth or USB.
- **Bluetooth Setup**——Power on wireless device, press [ETR] to search Bluetooth, then shows Bluetooth device, select confirm, press again to connect.
- **Partial Print**——Press [ ETR ] enter part print interface, then press [ETR] select data, see Fig 6-7-10. press [ SCALE ] to print data.
- **Print All**——Press [ ETR ] enter printing interface, press send to print.
- Printing function to send test results to computer by hyper terminal, see part 6.12 .
  - ▲ **Remark:** SU-300 has two types: with or without Bluetooth .
  - ◆ With Bluetooth: to connect with wireless printer, and USB wire printer.
  - ◆ Without Bluetooth: only can connect with USB cable to print.



Fig 6-7-9

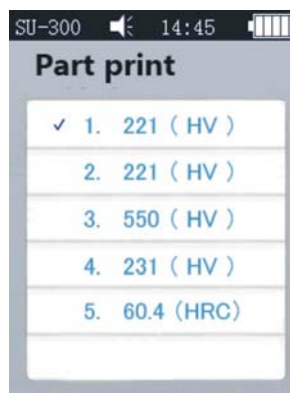

Fig 6-7-10

## 6.9 Calibration

### 6.9.1 Calibration Selection

- In Fig6-9-2 press [ ↑ ] [ ↓ ] select, then press [ MAT ] confirm. ( Make calibration before test ) ; Then press [ ↑ ] [ ↓ ] choose calibration group and press [ SCALE ] delete calibration data.
- ▲ **Remark:** Press [ MAT ] in main interface can enter calibration page.

- **Calibration Reasons:**

- a) If in the process of the hardness tester verification on the reference hardness block the readings are stable but differ from the nominal value of the reference hardness block;
- b) after long period of storage (more than 3 months);
- c) After intensive operation (more than 200.000 measurements for ultrasonic probe);
- d) In case of considerable change in the conditions of operation (ambient temperature, humidity etc).

### 6.9.2 Calibration Setting

- **Calibration Preparation:**

In interface as show in Fig6-9-1, switch into calibration settings by [ ↓ ] or [ ↑ ] , press [ ETR ] enter calibration settings as Fig6-9-3.

- ◆ **Probe Selection:** Before calibration, firstly select probe type. If you select motorized probe, enter into [ System ] – [ Test Setting ] – [ Indenter Type ] – select motorized probe. If you select manual probe, select manual probe as same steps. Be sure to confirm probe has been connected with machine, otherwise calibration cannot make.

- ◆Edit Calibration Name: Fig6-9-3 press 【 ↑ 】 【 ↓ 】 select Material (system default name is Calibration ) , red words means already selected, then press 【 ETR 】 enter edit page and edit calibration name.

Note: Calibration name is advised to edit according to probe type and testing material, which is convenient to identify calibration data, so you can test directly when you meet same material without calibration, significantly saving time.

- ◆Enter Normal Value: In Fig6-9-3 page press 【 SCALE 】 select scales, hen press 【 ↑ 】 【 ↓ 】 select Normal, then input Normal value according to hardness block. This value can be input before or after calibration action.

Note: Please input Normal Value after selecting scales, otherwise the value input will be delete when you select scales.



Fig 6-9-1

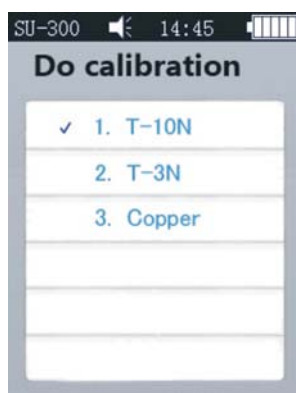

Fig 6-9-2

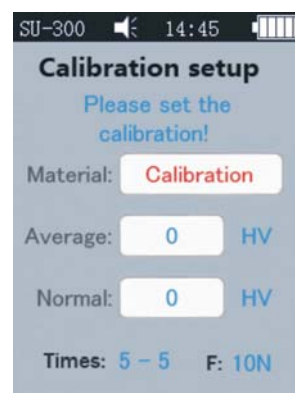

Fig 6-9-3

### 1)Calibration Step

After setup above steps,if probe is connected, press 【 MAT 】 enter testing page ( then it will show Please test 5-time to get a average value... ) , then you can calibrate by hardness block.

Please be sure to make probe vertically contact hardness block, motorized probe press red button/manual probe hold by hand to contact hardness block in constant speed, test 5 times in different position, test result shows in 【 Average 】 . When you finish 5-time tests, system will give beep for two times and interface will show “Calibration Complete”, then goes to save steps.

Note: Don't press 【 Scale 】 before saving calibration data. It's used to switch testing scale in calibration setting, once pressed, unsaved data will be cleared. If you press it accidentally, please select scale and calibrate according to steps mentioned above.

### 2)Save Calibration Data Setup

- ◆Before calibration, Material and Normal value have been filled, it will pop up box "Is it ok about calibration?", then press confirm to save.

- ◆If Normal Value is not input before calibration, after 5 tests, Normal Value will be automatically filled in same with Average value, and pop up box “then input the normal to finish the calibration”. Please press 【 ← 】 or 【 → 】 adjust to hardness block value, or press 【 ETR 】 edit, then press 【 MAT 】 to save, and you finish the calibration. This calibration data will be listed, and the following test will test according the calibration data.

### 3)Cancel Calibration

When end-user make calibration by himself, he should be accompanied with professional staff. Test the value of standard hardness block more than 5 times, test result should be within error range, see 6.10. If test result is out of error significantly, you have to cancel this calibration data and calibrate again.

HOW TO CANCEL: press [MAT], system will pop up box “Exit Correction?”, first confirm it then press [ETR], then canceled, and establish new calibration.

### ● Calibration on specific material

When you know the hardness value of the material, the calibration steps are the same when you calibrate by standard hardness block. The different is here we use a kind of material which given hardness value by others bench hardness tester while not standard block. If you use the calibration data by hardness block, when you test aluminum, the value will have significant error. In order to test accurately, you have to calibrate the Ultrasonic Hardness Tester by the given hardness value of the material, which guarantee accuracy and stability. Special material will have significant deviation during testing, please set according to 6.9.3.(calibration upon special material is same as common action).

### ● Calibration Notice

- ▲ When in calibration interface, first press [MAT], then vertically contact probe with standard block, if no reaction, take up probe and press [MAT] again, get 5 measurements.(please press red button again when using motorized probe).
- ▲ If shows ↑, it means hardness value exceeds max value of this hardness scale; shows ↓, means hardness value lower than tested hardness scale. If you meet problems mentioned above, please see the 7th part in the manual to solve them.

### 6.9.3 Optional Setting

In practical testing, Elastic Modulus differs among different materials, test result will exceed its original value by Ultrasonic Hardness Tester, please see example below to solve it flexibly.

#### Operation method:

- 1) In Fig 6-9-4, press orientation button to adjust HZ value (default value is OHZ), or press [ETR] to edit.  
Note that you need to add “-” or “+” in front of your value number, otherwise you cannot enter the value, the system will indicate you “Error”
- 2) After enter the value, press 【MAT】 to save it,. The system goes back to [Calibration Option]- [Calibration Setup], create new calibration group, see part 6.9.2, then we can test the hardness value.

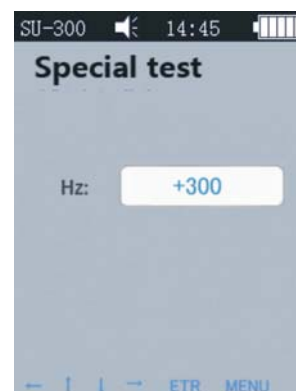

Fig 6-9-4

Take aluminum of 200HV for example, the test result may be around 910HV without calibration. End-user can calibrate directly, however it will make test not stable, so you can consider special calibration. It's known to us, that the frequency value is smaller when it has high hardness value; The opposite is the same; So when test result is bigger than the original value, input +HV value, and if smaller, input -HV value. According the test above, test result is obviously larger than original value, so you can input +HV value to make the value display normal. 910HV is more than 700 HV larger than 200HV, normally we consider 2HV as 1 to adjust the HZ value to +350. Enter into calibration setting again, please calibrate according to 6.9.2, and then the Average value should display about 230HV, it's much similar. Test 5 times, adjust the Normal Value to 200HV, save it, and you have finished special calibration. When meeting other special material, do it flexibly mentioned above to solve it.



- Note:**
- 1) Do not make special calibration unless the material is really special, in case of unnecessary error.
  - 2) If you need to calibrate another special material, please take the default calibration value to test the hardness value, input HZ value according to proportion  $HV:HZ = 2:1$ , make another calibration.
  - 3) Ultrasonic Hardness Tester has memory function, eternally save the last input HZ value, if you have to delete it, please restart the Ultrasonic Hardness Tester, or input HZ value as 0, then press [MAT] to save the setting.

## 6.10 DIN50159-1-2008 Permitted Error and Repeatability

Table 6-10

DIN50159 Permitted Error and Repeatability (%)				
Hardness Scale	250HV	250 500HV	500 800HV	800HV
HV0.1	6	7	8	9
HV0.3	6	7	8	9
HV0.8	5	5	6	7
HV1	5	5	6	7
HV5	5	5	5	5
HV10	5	5	5	5

## 6.11 Battery

There is rechargeable battery (4.2V, 4800mAh) installed in main unit. When the battery runs out, the upper right corner of the main interface will display  to remind you battery charging in time. Insert one end of charger into the left socket of instrument, plug in the 220V electricity and charging. Fully recharging time is 8 hours, while not less than 4 hours for one charging. When the charging is completed, the upper right corner of the main interface will display , please unplug the charger.

## 6.12 Data Transmission

Please download CH340 Driver (USB driver) to your computer, Connect instrument and computer by data transmission cable, four pins socket connect with instrument and the other side connect with computer host.

In Win XP system, click start -> program -> accessory -> communication -> hyper terminal, set up new hyper terminal, then name it. Select COM port, Baud rate is 9600, the others information no needs to be modified.

When everything is ready, then we can send data to computer.

In win7 system, there is no hyper terminal, we have to install one, note the Baud rate is 9600, others no need to change.

A) Enter Printing setup - Print partial/ Print all, then we can send data to computer

B) when on-line operation is switch on, and connect hyper terminal, then each test result will be sent to computer timely.

## 7、 Troubleshooting

Failure phenomenon	Analysis	Settlement
Power on Failure	Battery use out or damaged	Recharging or replace new battery
No measuring value	<ol style="list-style-type: none"> <li>no press ETR button.</li> <li>Probe or socket pin of main unit is crooked.</li> </ol>	<ol style="list-style-type: none"> <li>Hand the probe up and then press ETR button again .</li> <li>Check if the data line connected with the probe and main unit is problem, if the socket pin and pinhole is damaged.</li> </ol>
<ol style="list-style-type: none"> <li>no value after measurement but display ↑ ↓ ,</li> <li>no response or response after a long time</li> </ol>	<ol style="list-style-type: none"> <li>The hardness value of the tested sample is higher or lower than the scale range when using.</li> <li>First use the probe to put the specimen and then press ETR button , sometimes this problem will be happened ,the power is too strong pressed on the probe.</li> </ol>	<ol style="list-style-type: none"> <li>Change the hardness scale and then measuring again .If still have problem , please measure on the desktop hardness testers to check the result.</li> <li>First press ETR button ,probe gently touch the specimen in vertical direction, no need a strong power to press .</li> </ol>
1. Measured value is not correct.	1. The probe is damaged or the sample is too rough.	<ol style="list-style-type: none"> <li>Please check the probe head is damaged; if the tested value of the specimen's standard hardness block is stable ; calibrate again ; use the measured material to calibrate .</li> </ol>
1.Deviation measurement	1.As the structure positions are changed when disassembly instrument , leads to the inaccuracy data of calibration groups, or the big difference between the calibrated material and tested material, (such as the original calibration in instrument is steel material but now you change aluminum material to measure.	<ol style="list-style-type: none"> <li>Please try again with the tested samples made of the same material specimen for calibration, and then measure.</li> </ol>

## 8、 Maintenance

- 8.1 Before and after measurements, please use the non-woven fabric with a little alcohol to wipe the probe head gently and clean the dirty mark. After measurements, use clean cloth to clean the main unit and the surface stains of the probe .
- 8.2 Recharging before long time no operation.
- 8.3 Please put the probe cap on the probe when no using, because the diamond indenter on probe is hard and brittle, easy to be fell off when meeting violent impact . Please put the main unit and accessories into the assorted toolbox .

## 9、 Warranty Attention

- 1、 Two years warranty for main unit only for quality problem, the others accessories are not under warranty.  
Refer packing list of ultrasonic hardness tester.
- 2、 Please show invoice and warranty card in case need repair.
- 3、 We ask for charges for accessories not under warranty.

## 10 、 Storage/Transportation Attention

Storage should be far away from the vibration, corrosion, moisture, dust, also should be stored at a normal temperature and humidity. Please put in the original packing box before transportation to avoid any damage.

**▲Note:** Operation manual will be updated without further notice, latest edition will be sent to customers by email timely.



ISO 9001:2015 Certified Company



**Sinowon Innovation Metrology Manufacture Limited**

Address:A1, KaiSong Park, 2# Baima Xianfeng Road, South District, DongGuan, China (523080)

Tel:0086-769-23184144 Fax:0086-769-22854144

Web:www.sinowon.com E-mail:sinowon@188.com

**Hotline:0086-137-2828-8444**

Authorized Distributors: