



SHANGHAI CHZ LIGHTING CO.,LTD

No.518, Xiangjiang Road, Shanghai, China

T/W +34 615 743 994

T/W +86 133 9137 5176

T/W +86 159 2122 3752

M sales@chz-lighting.com

WWW.CHZ-LIGHTING.COM



**FERNANDO NAVARRETE
GONZALO DE ANDRÉS**



OFFICIAL PARTNER



CHZ-LIGHTING

OFFICE LIGHTING

(2024-2025)

Creative Lighting, Healthy Living

Profile

SHANGHAI CHZ LIGHTING CO.,LTD., established in 2013, is one of the leading manufacturers of LED lighting products in China. Our headquarter is located at Jiading of Shanghai, we have three production bases in Shanghai, Hangzhou and Ningbo city, with a total of 12,000m² plant area and 1.0M sets of LED lights' production per year.

We adhere to the idea of "technology first", and cooperate with Fudan University to continuously develop new products. Our products have covered office lighting, industrial lighting, flood lighting, stadium lighting, road lighting, and solar lighting. We offer, not only qualified lights, but also complete intelligent lighting solutions.

By continuous high investment on management and R&D, we has passed ISO9001, ISO14001, ISO45001 and ISO50001 system certifications. Meanwhile, we have got ENEC, ENEC++, CE, CB and ETL quality certifications proved by famous labs, such as TUV. Moreover, we have been rewarded lots of honors by the government, such as "National High-tech Enterprise", "Shanghai Technological Enterprise" and etc.

Our products have been exported to over 80 countries around the world and used for thousands of public projects. By high quality and excellent service, "CHZ LIGHTING" has won very good reputation in those markets. We will continue to work hard and tirelessly strive to build "CHZ LIGHTING" as one globally renowned brand.

Awards



Qualification



ISO9001



ISO14001



ISO45001



ISO50001

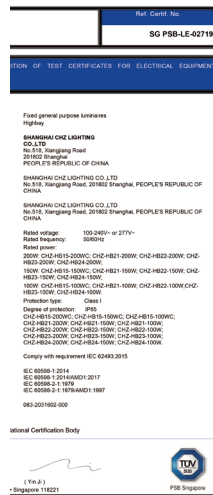
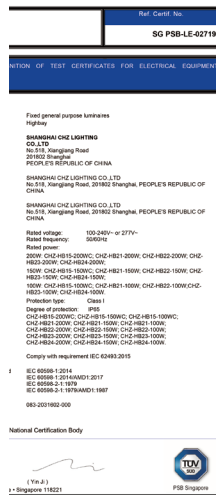
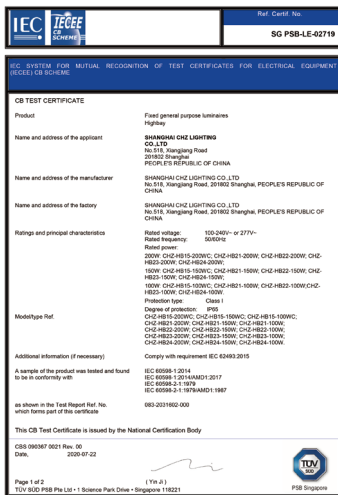

CB Certification

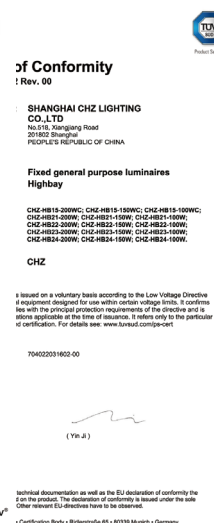
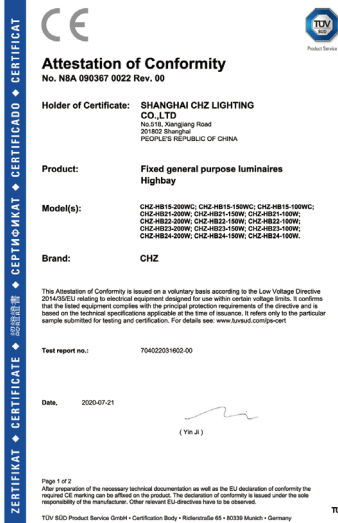

CE Certification

Company Image



Shanghai Headquator



Europe Company



Spain Warehouse



Marketing Department



R&D Department



Training Meeting



Assembling line



Testing Line

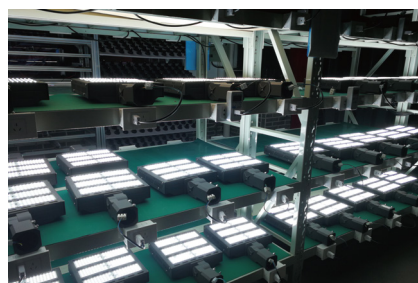

Old Aging



Outdoor Development



Argentina team



Team action



Spain Team



Spain Team



Shareholder Dinner

OFFICE LIGHTING



CHz[®]

Office Lighting

SUPERIORITY

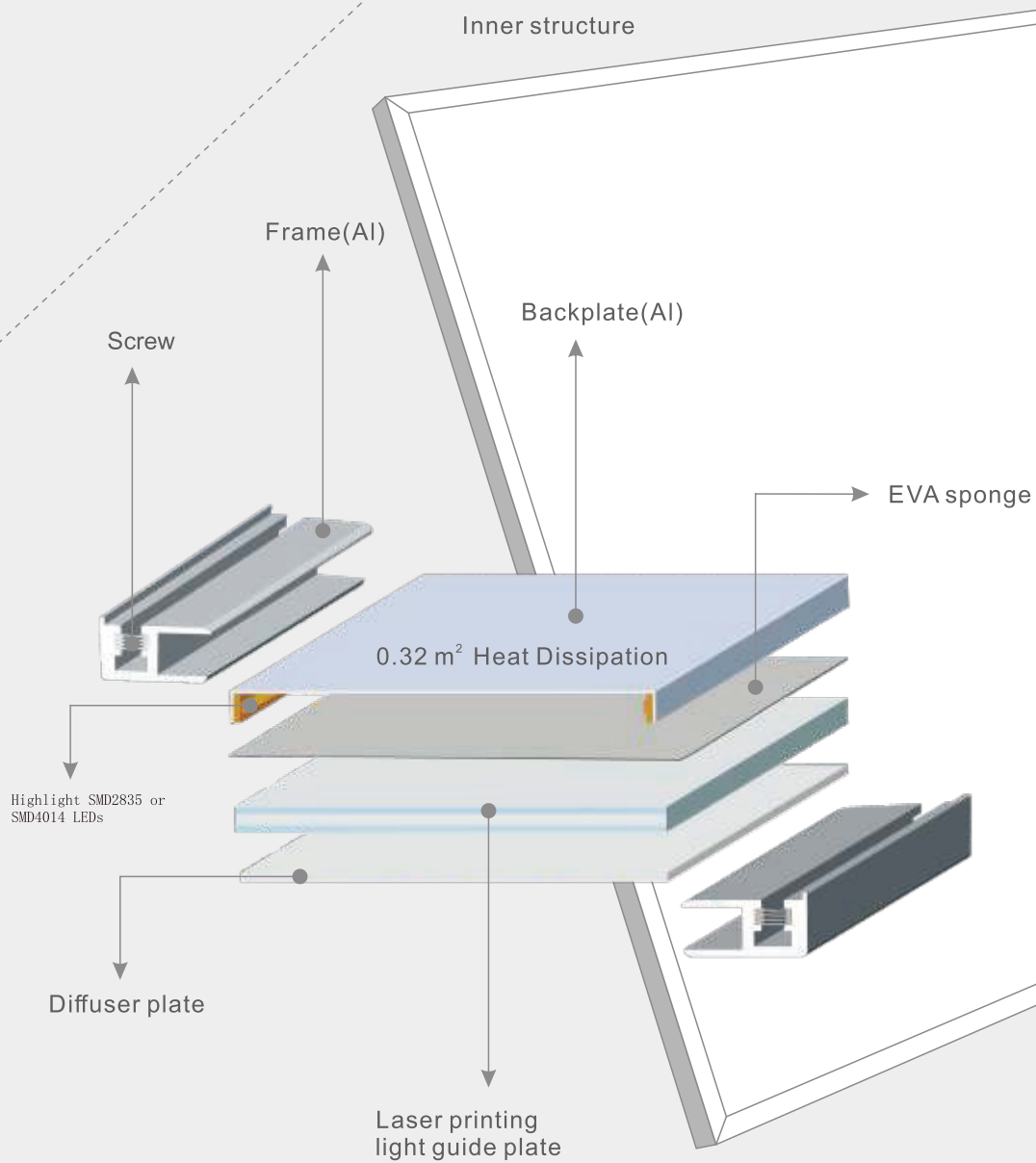

■ CCT: 2700K 3000K 4000K 5000K 5700K 6500K

Available:

80/100
/120
lm/w

UGR<19

Heat Dissipation Feature:



Al backplate dissipation feature prolongs the lifespan of LEDs, 25°C temperature rising, 0.32m² (600x600mm) dissipation area.

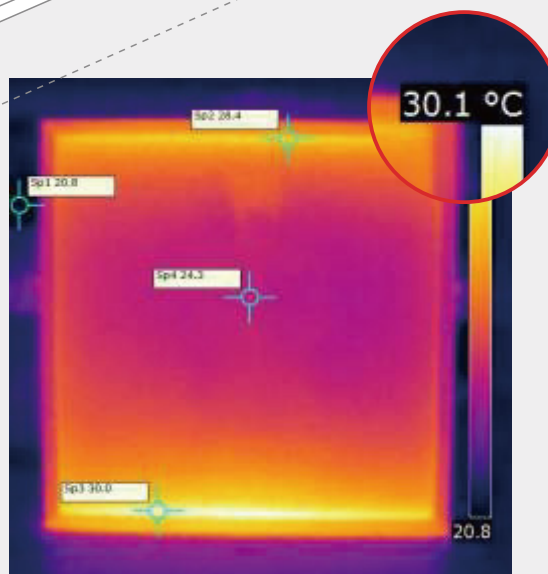

CHz[®]**Office Lighting**

CE C B ROHS

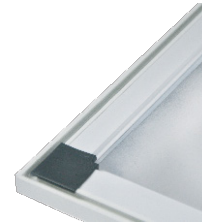
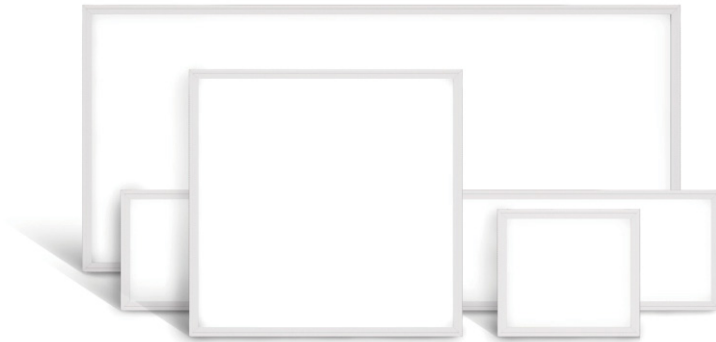

❖ Panel - ENEC TUV Series

Product Feature:

- A. Solid-state LED light source, instant start, long lifespan, free from maintenance.
- B. Well designed solid aluminum frame and galvanized steel sheet, with quick heat ventilation.
- C. Multi-installation solutions, with aluminum backplate cooling Model Number Definition.
- D. Multi control ways optional, such as 0-10V, PMW, DALI, according to the applications.
- E. PMMA Light guide panel, Chimei PS diffuser, Samsung SMD4014 with 5 Years' Warranty.
- F. IP degree can be IP20, IP54 or IP66 for options, default IP20 degree if not special required.

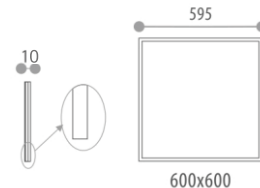

Application:

Widely used in hotel, meeting room, factory, office, school, hospital, residence, infrastructure and etc.

Technical Parameters:

Model No.	Power (W)	Input volt (V)	LED TYPE	LED's (pcs)	Lumen (LM/W)	PF	CCT (K)	CRI	Guide	Diffuser	Product Size(mm)		
											L	W	H
CP6060-EN352	35.2	200-240	SMD2835	192	>100	>0.9	3000-6500	>80	PMMA	PS	595	595	10
CP6060-EN370	37.0	200-240	SMD2835	192	>100	>0.9	3000-6500	>80	PMMA	PS	595	595	10
CP6060-EN422	42.2	200-240	SMD2835	192	>100	>0.9	3000-6500	>80	PMMA	PS	595	595	10
CP6060-EN475	47.5	200-240	SMD2835	192	>100	>0.9	3000-6500	>80	PMMA	PS	595	595	10
CP1230-EN352	35.2	200-240	SMD2835	192	>100	>0.9	3000-6500	>80	PMMA	PS	1195	295	10
CP1230-EN370	37.0	200-240	SMD2835	192	>100	>0.9	3000-6500	>80	PMMA	PS	1195	295	10
CP1230-EN422	42.2	200-240	SMD2835	192	>100	>0.9	3000-6500	>80	PMMA	PS	1195	295	10
CP1230-EN475	47.5	200-240	SMD2835	192	>100	>0.9	3000-6500	>80	PMMA	PS	1195	295	10
CP1230-EN704	70.4	200-240	SMD2835	384	>100	>0.9	3000-6500	>80	PMMA	PS	1195	295	10

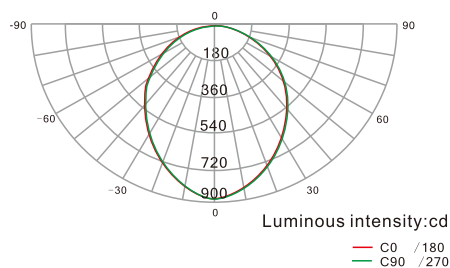

ROHS CE

CHz[®]

Office Lighting

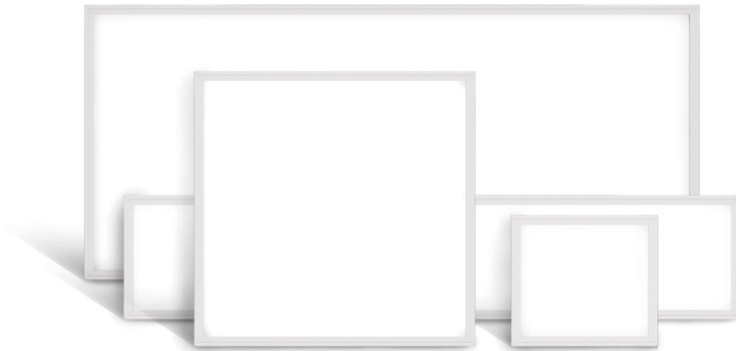

❖ Panel - DL Series

Product Feature:

- A. Overall use of direct light-emitting structure, compared with side light structure, higher light efficiency, less heat, less light attenuation;
- B. Using aluminum alloy frame, oxidation or baking process, the appearance is simple and generous; due to the principle of direct light emission, compared with side light, no light guide plate is required, which effectively reduces the material cost;
- C. Adopt high-quality SMD2835 chip (single 1W), good consistency, high light efficiency, color temperature 3000K-6500K; at the same time using intelligent constant current drive, no strobe, high conversion efficiency, stable performance and long life.

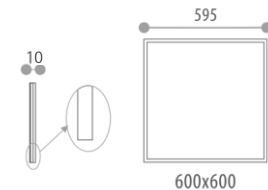

Application:

Widely used in hotel, meeting room, factory, office, school, hospital, residence, infrastructure and etc.

Technical Parameters:

Model No.	Power (W)	Input volt (V)	LED TYPE	LED's (pcs)	Lumen (LM/W)	PF	CCT (K)	CRI	Guide	Diffuser	Product Size(mm)		
											L	W	H
CP6060-40W	40	200-240	SMD2835	48	>100	>0.9	3000-6500	>80	NO	PS	595	595	30
CP1230-40W	40	200-240	SMD2835	48	>100	>0.9	3000-6500	>80	NO	PS	1195	295	30
CP1230-80W	80	200-240	SMD2835	96	>100	>0.9	3000-6500	>80	NO	PS	1195	595	30

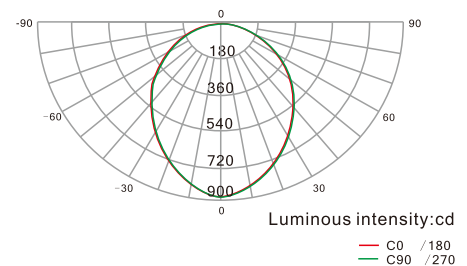

Installation mode

▶ 1.Surface Mounted



Model:CHZ-CP6060
For 600x600mm LED Panel

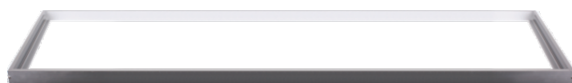

Model:CHZ-CP1230
For 300x1200mm LED Panel



Model:CHZ-CP1260
For 600x1200mm LED Panel



▶ 2.Suspending Kits

Model 1:CPS-MBDJ-01



Model 2:CPS-MBDJ-02



▶ 3.Recessed

Model : CPS-THDXZJ-01

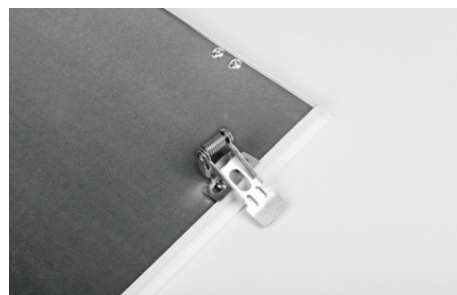

INSTALLATION DIAGRAM

■ Non-dimmable installation Diagram

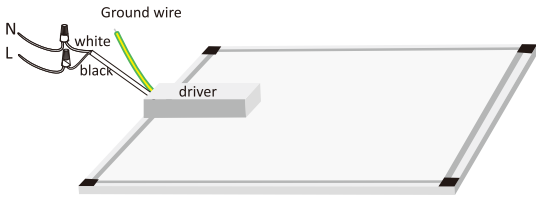

■ 0-10V dimmable installation Diagram

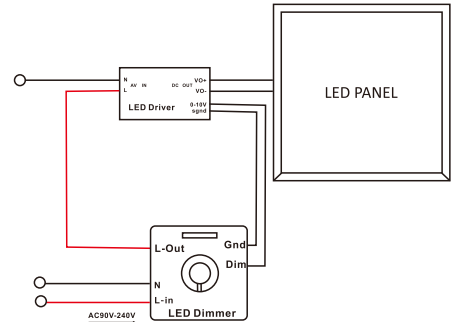

■ Emergency pack installation diagram

▶ 1. Emergency (for 20~100W Led lamp)



• Output:3W/5W/8W •



Charging time: • 14h

Use of time: 3h

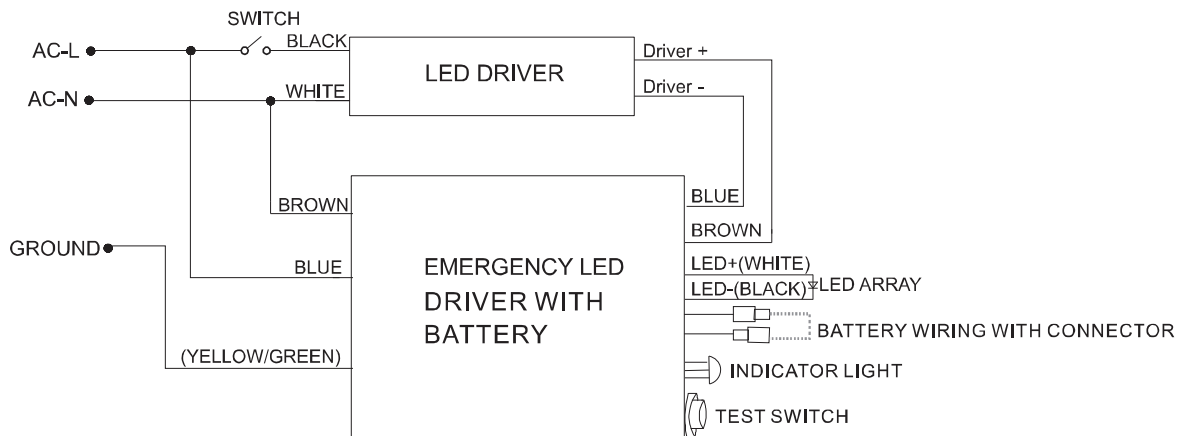

▶ 3. 2.4G Intelligent Control LED Panel Light



CCT Changeable



Dimmable



Night Lamp



30m Distance

2 modes option

① Wall switch control



② Remote control

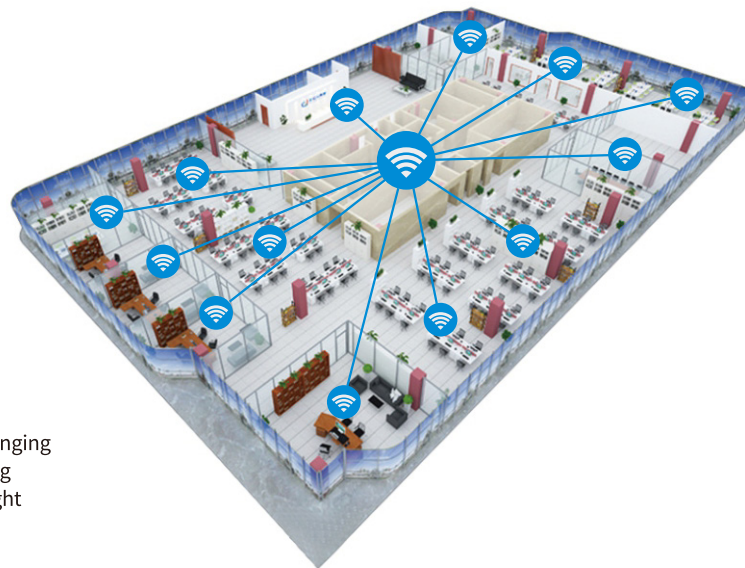

- 1. CCT changing
- 2. Dimming
- 3. Night light



Morning 6:30

5000K
Day White



Noon 12:30

4000K
Natural White



Night 19:30

3000K
Warm White

Dimming function

■ PUSH dimming

Turn on the driver or turn it into standby mode by pressing the switch for 0.1-1s(Short press).

Change the brightness level by pressing the switch for 1-5s(Long press).

If the PUSH function to open the AC power supply, the initial state for the standby, the need to short press PUSH switch boot.

If the drivers in push dimming state need to synchronize multiple dimming, rst,turn on the AC power to confirm each driver are stand by, then long press PUSH switch to boot.

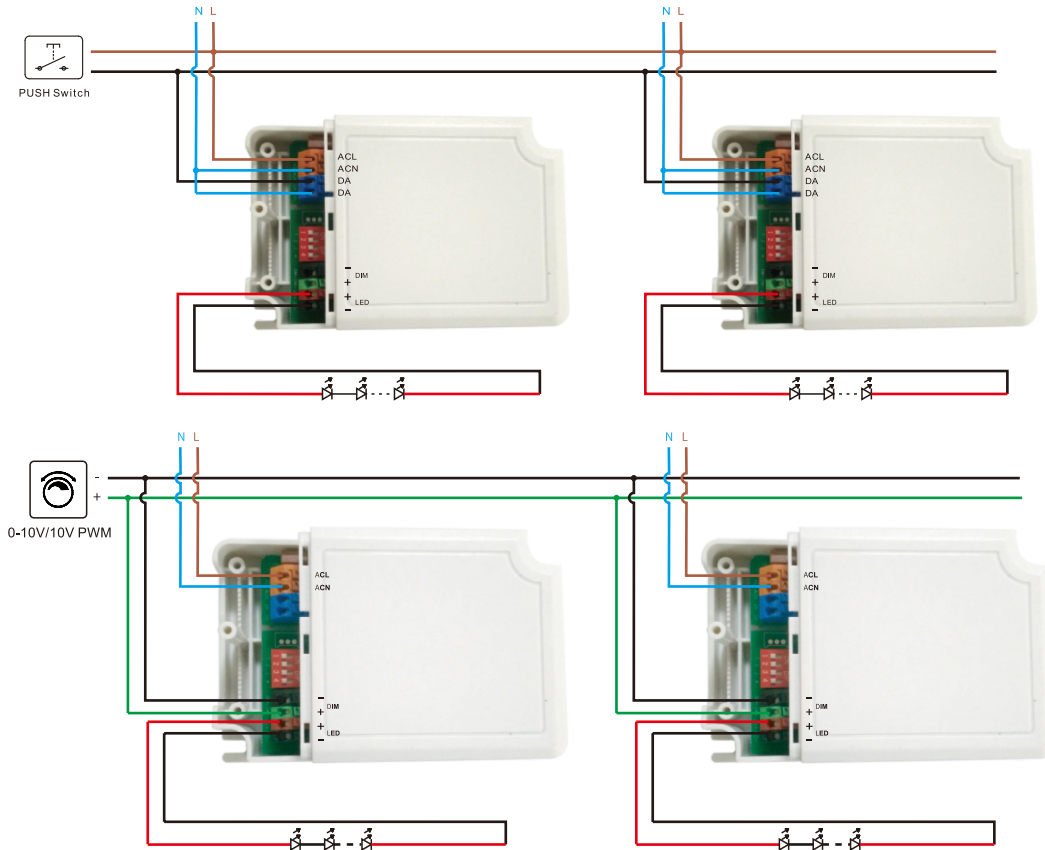

■ Multi machine parallel synchronous dimming

Synchronization up to 16 drivers.

Maximum cable length between each units : 20 meters.

■ DALI dimming

DALI protocol comprises 16 groups and 64 addresses.

DALI INPUT	MIN	TYP	MAX
high level	9.5V	16V	22.5V
low level	-6.5V	0V	6.5V

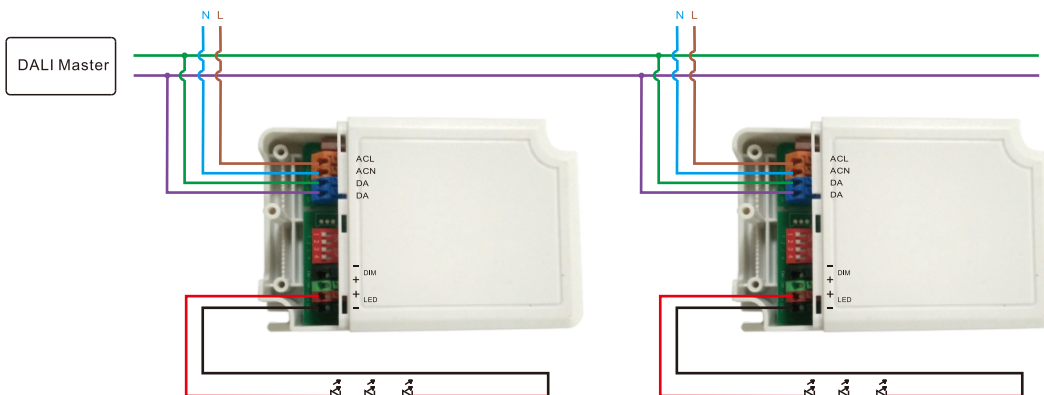



CHZ LIGHTING (SPAIN)

Pol. Ind. Trobika. Martintxone Bidea,
1.Mungia, Bilbao

Contact: Mr. Igor
Tel: (0034) 615 743 994
Mail: lgarcia@chzspain.com

CHZ LIGHTING (ARGENTINA)

Calle N°38 N°559, Código Postal (6600),
Mercedes, Provincia de Buenos Aires.

Contact: Mr. Fernando
Tel: (0054) 9 2324 435127
Mail: fernando@chz-lighting.com

CHZ LIGHTING (NIGERIA)

Abuja Office: Mr. Jide
Tel: (00234) 802 705 7715
Mail: jide@chz-lighting.com

Uyo Office: Mr. Francis
Tel: (00234) 808 936 7161
Mail: francis@chz-lighting.com

CHZ LIGHTING (USA)

Fu Rowland Heights Road, Los Angeles

Contact: Ms. Hidy
Tel: (001) 626 629 2217
Mail: hidy@chz-lighting.com

CHZ LIGHTING S.R.L (Romania)

Add: Fundac Sf. Teodor nr.1, Iasi, Romania

Contact: Mr. Nicolae Dragos
Tel: +40 722 39 66 77
Mail: chz.romania@chz-lighting.com

CHZ LIGHTING BURKINA SARL

Add: 08 BP, 11147 Ouaga 08, Burkina Faso

Contact: Mr. Abdoul
Tel: + 226 6610 2186
Mail: martin@chz-lighting.com