

# ABRASIVES



深圳市永昌源科技开发有限公司

ShenzhenYongchangyuan Technology Development Co., Ltd

Dental Burs 牙科车针、磨头

Vol. 8 : 2024

# About Us

Yongchangyuan Technology Development Co., Ltd Abrasives Company Limited are specialized in Rotary things of dental, Jewelry, Beauty or Hobbies & DIY ( Do it Yourself ) .

Our products include Diamond Burs and discs, Tungsten Carbide Burs or cutters, Flexible Rubber Burs, Wheels or Points, Polishing Brushes, Mounted Stones, CAD/CAM Milling Burs or any Diamond Stones or Polishers.

Our Rotatory Instruments are widely applied to Cut, Grind, Finish, Polish any materials of Zirconia, Lithium Disilicates, Porcelain (Ceramics) , Alloy or Metal, Acrylic ( Resin ) , PEEK, Composites etc . They can match any Handpiece of FG (Friction Grip) , RA/CA(Right Angle), HP conveniently and precisely .

We have obtained the certificates of ISO 13485 and CE since the year of 2015 . We provide innovative and professional products and service.

Whoever you are dentist or technician, we always make you relaxing, safe and efficient. We are your best friend in dentistry, Jewellery or Hobbies.

Our Product Has the Ability to fulfill Your Standard and Sensational Satisfaction. We are anticipating to have you as one of our important clients with Best Wishes.



ISO 13485



CE 0197



Established in 2007



Clinic Part  
临床类

Page 3 - 28 第3至28页



**Diamond burs** 金刚石车针

Page 4 - 12 第4至12页

**Diamond Ortho-strips**  
金刚石锯弓

Page 13 第13页

**Diamond Finishing Strips**  
金刚石抛光条

Page 14 第14页

**Tungsten Carbide burs**  
钨钢车针

Page 15 - 18 第15至18页

**White Stones** 白车石  
**Green Stones** 绿车石

Page 19 第19页

**Diamond Stones, Polishers**  
陶瓷（橡胶）金刚车石磨头

Page 20 第20页

**Finishing or Polishing Burs  
after Debonding**  
(脱胶后) 洁牙磨头

Page 21 第21页

**Twin-Color Silicon Polishers**  
硅胶抛光磨头

Page 22 第22页

**Silicon Polishers**  
硅胶抛光磨头

Page 23 第23页

**Polishing Brushes** 抛光刷

Page 24 第24页

**Mandrels, Sterile Blocks**  
夹针、消毒盒

Page 25 第25页

**Kit** 套装

Page 26 - 31 第26至31页

**Samples Collection**  
样品册

Page 32 第32页

# Diamond Bur

金刚砂车针



## Advantages

1. Strictly comply with ISO Standard ;
2. Sharper and More Efficient ;
3. Durable and Valuable ;
4. Full Range of shapes and grits.
5. Fastly develop new items.
6. Individual Design and OEM Service



0.8 — Head Size  
19.0 — Total Length  
001 — ISO No.  
(801) — Ref.

001-008M — Item No.  
BR-49 — Ref.

## Grit

- S : Black / Super Coarse
- C : Green / Coarse
- M : Blue / Medium
- F : Red / Fine
- EF : Yellow / Extra Fine

FG 314 Shank	0.8 19.0 001 (801)	1.0 19.0 001 (801)	1.2 19.0 001 (801)	1.4 19.0 001 (801)	1.6 19.0 001 (801)	1.8 19.0 001 (801)	2.1 19.0 001 (801)	2.3 19.0 001 (801)	2.5 19.0 001 (801)	2.9 19.0 001 (801)
<b>M</b>	001-008M BR-49	001-010M BR-45	001-012M BR-46	001-014M BR-41	001-016M BR-40	001-018M BR-31	001-021M BR-28	001-023M BR-26	001-025M BR-25	001-029M BR-23
<b>S</b>				001-014S BR-41S	001-016S BR-40S	001-018S BR-31S	001-021S BR-28S	001-023S BR-26S	001-025S BR-25S	001-029S BR-23S
<b>C</b>			001-012C BR-46C	001-014C BR-41C	001-016C BR-40C	001-018C BR-31C	001-021C BR-28C	001-023C BR-26C	001-025C BR-25C	001-029C BR-23C
<b>F</b>			001-012F BR-46F	001-014F BR-41F	001-016F BR-40F	001-018F BR-31F	001-021F BR-28F	001-023F BR-26F		
<b>EF</b>			001-012EF BR-46EF	001-014EF BR-41EF	001-016EF BR-40EF	001-018EF BR-31EF	001-021EF BR-28EF	001-023EF BR-26EF		

Ball , Round /BR

FG 314 Shank	1.2 22.0 697 (801L)	1.4 22.0 697 (801L)	1.6 22.0 697 (801L)	1.8 22.0 697 (801L)	1.2/2.3 19.0 002 (802)	1.4/2.3 19.0 002 (802)	1.6/3.5 19.0 002 (802)	1.8/2.3 19.0 002 (802)
<b>M</b>	697-012M BR-L46	697-014M BR-L41	697-016M BR-L40	697-018M BR-L31	002-012M BC-43	002-014M BC-42	002-016M BC-32	002-018M BC-31
<b>S</b>			697-016S BR-L40S	697-018S BR-L31S				
<b>C</b>	697-012C BR-L46C	697-014C BR-L41C	697-016C BR-L40C	697-018C BR-L31C				

Round with Long Neck /BR

Round with Collor /BC

FG 314 Shank	1.0(0.8)/1.0 19.0 010 (805)	1.2(0.9)/1.2 19.0 010 (805)	1.4(1.0)/1.6 19.0 010 (805)	1.6(1.1)/1.8 19.0 010 (805)	1.4(1.1)/4.0 19.0 225 (807)	1.6(1.2)/4.0 19.0 225 (807)	1.8(1.3)/5.0 19.0 225 (807)
<b>M</b>	010-010M SI-45	010-012M SI-46	010-014M SI-47	010-016M SI-48	225-014M SI-50	225-016M —	225-018M SI-51
<b>S</b>				010-016S SI-48S			
<b>C</b>		010-012C SI-46C	010-014C SI-47C				

Inverted Conical / SI



FG 314 Shank							
	<b>M</b>	019-010M DI-41	019-014M DI-42	038-032M EX-11	039-035M EX-12	044-045M WR-44	067-042M WR-11
<b>S</b>			038-032S EX-11S	039-035S EX-12S			
<b>C</b>			038-032C EX-11C	039-035C EX-12C			068-042C WR-13C

Double Conical











Wheel









FG 314 Shank										
	<b>M</b>	109-010M SF-41	109-012M SF-31	109-014M SF-42	109-016M —	110-012M SF-20	110-014M SF-21	110-016M SF-15	111-012M SF-11	111-014M SF-12
<b>S</b>		109-012S SF-31S	109-014S SF-42S		110-014S SF-21S	110-016S SF-15S	111-012S SF-11S	111-014S SF-12S	111-016S SF-13S	
<b>C</b>		109-012C SF-31C	109-014C SF-42C	109-016C —	110-012C SF-20C	110-014C SF-21C	110-016C SF-15C	111-012C SF-11C	111-014C SF-12C	111-016C SF-13C
<b>F</b>	109-010F SF-41F	109-012F SF-31F			110-012F SF-20F	110-014F SF-21F	110-016F SF-15F	111-012F SF-11F	111-014F SF-12F	111-016F SF-13F
<b>EF</b>					110-014EF SF-21EF			111-012EF SF-11EF	111-014EF SF-12EF	111-016EF SF-13EF

Flat End Cylinder











FG 314 Shank						
	<b>M</b>	130-012M CP-11	130-014M CP-12	130-016M CP-13	131-012M —	131-014M —
<b>C</b>	130-012C CP-11C	130-014C CP-12C	130-016C CP-13C	131-012C —	131-014C —	131-016C —

Cylinder, end cone, pointed

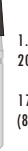







FG 314 Shank	 1.0/4.0 19.0 139 (838)	 1.2/4.0 19.0 139 (838)	 1.4/4.0 19.0 139 (838)	 1.4/6.0 21.0 140 (880)	 1.2/8.0 22.0 141 (881)	 1.4/8.0 22.0 141 (881)	 1.6/8.0 22.0 141 (881)	 1.4/10.0 23.0 142 (882)	 1.6/8.0 23.0 142 (882)	 1.2/0.2 21.0 150 (839)	
<b>M</b>	139-010M SR-41	139-012M SR-31	139-014M SR-42	140-014M SR-21	141-012M SR-11	141-014M SR-12	141-016M SR-13	150-012M EX-18			
<b>S</b>					141-012S SR-11S	141-014S SR-12S	141-016S SR-13S				
<b>C</b>				140-014C SR-21C	141-012C SR-11C	141-014C SR-12C	141-016C SR-13C	142-014C —	142-016C —		
<b>F</b>	139-010F SR-41F	139-012F SR-31F	139-014F SR-42F	140-014F SR-21F	141-012F SR-11F	141-014F SR-12F	141-016F SR-13F	150-012F EX-18F			
<b>EF</b>	139-012EF SR-31EF		140-014EF SR-21EF		141-012EF SR-11EF	141-014EF SR-12EF	141-016EF SR-13EF				
	Round End Cylinder							End Cut			

FG 314 Shank	 1.2/6.0 21.0 164 (852)	 1.2/8.0 22.0 165 (858)	 1.4/8.0 22.0 165 (858)	 1.0/10.0 22.0 166 (859)	 1.2/10.0 22.0 166 (859)	 1.4/10.0 22.0 166 (859)	 1.6/10.0 22.0 166 (859)	 1.8/10.0 22.0 166 (859)	
<b>M</b>	164-012M TC-26	165-014M TC-21	166-010M TC-27	166-012M TC-28	166-014M TC-10	166-016M TC-11	166-018M TC-16		
<b>S</b>	165-014S TC-21S		166-014S TC-10S			166-016S TC-11S	166-018S TC-16S		
<b>C</b>	165-014C TC-21C		166-014C TC-10C			166-016C TC-11C	166-018C TC-16C		
<b>F</b>	164-012F TC-26F	165-012F —	165-014F TC-21F	166-010F TC-27F	166-012F TC-28F	166-014F TC-10F	166-016F TC-11F	166-018F TC-16F	
<b>EF</b>	164-012EF TC-26EF	165-012EF —	165-014EF TC-21EF	166-010EF TC-27EF	166-012EF TC-28EF	166-014EF TC-10EF	166-016EF TC-11EF	166-018EF TC-16EF	
	Needle/TC								











FG 314 Shank	 1.4/11.5 24.0 167 (859L)	 1.6/11.5 24.0 167 (859L)	 1.8/11.5 24.0 167 (859L)
<b>C</b>	167-014C —	167-016C —	167-018C —
	Needle/TC		

FG 314 Shank										
	1.0(0.6)/3.0 19.0	1.2(0.7)/4.0 19.0	1.4(0.8)/4.0 19.0	1.6(0.9)/4.0 19.0	1.8(1.0)/5.0 20.0	2.1(1.5)/5.0 20.0	1.4(0.7)/6.5 21.0	1.6(0.8)/6.5 21.0	1.0(0.6)/8.0 22.0	1.2(0.7)/8.0 22.0
<b>M</b>	169-010M TF-41	170-012M TF-42	170-014M TF-43	170-016M TF-31	170-018M TF-23	170-021M TF-22	171-014M TF-20	171-016M TF-21	172-010M TF-07	172-012M TF-08
<b>S</b>									171-016S TF-21S	
<b>C</b>	170-014C TF-43C						171-014C TF-20C			
<b>F</b>	170-014F TF-43F						171-014F TF-20F	171-016F TF-21F	172-012F TF-08F	
<b>EF</b>									171-016EF TF-21EF	

Flat End Cone

FG 314 Shank									
	1.4(0.7)/8.0 22.0	1.6(0.8)/8.0 22.0	1.8(0.9)/8.0 22.0	2.3(1.3)/9.0 22.0	1.4(0.7)/10.0 24.0	1.6(0.8)/10.0 22.0	1.8(0.9)/10.0 22.0		
<b>M</b>	172-014M TF-09	172-016M TF-10	172-018M TF-56	172-023M TF-14	173-014M TF-11	173-016M TF-12	173-018M TF-13		
<b>S</b>	172-014S TF-09S	172-016S TF-10S			173-014S TF-11S	173-016S TF-12S	173-018S TF-13S		
<b>C</b>	172-014C TF-09C	172-016C TF-10C	172-018C TF-56C	172-023C TF-14C	173-014C TF-11C	173-016C TF-12C	173-018C TF-13C		
<b>F</b>	172-014F TF-09F	172-016F TF-10F	172-018F TF-56F		173-014F TF-11F	173-016F TF-12F	173-018F TF-13F		
<b>EF</b>		172-016EF TF-10EF			173-014EF TF-11EF	173-016EF TF-12EF	173-018EF TF-13EF		

Flat End Cone

FG 314 Shank										
	1.0(0.6)/4.0 19.0	1.2(0.7)/4.0 19.0	1.4(0.8)/4.0 19.0	1.6(0.9)/4.0 19.0	2.0(1.0)/5.0 19.0	1.2(0.7)/6.5 21.0	1.4(0.7)/6.5 21.0	1.6(0.8)/6.5 21.0	1.8(1.0)/6.5 21.0	2.0(1.1)/6.5 21.0
<b>M</b>	196-010M CR-41	196-012M CR-31	196-014M CR-42	196-016M CR-12	196-020M CR-11	197-012M —	197-014M TR-20	197-016M TR-21	197-018M TR-62	197-020M TR-63
<b>S</b>									197-016S TR-21S	
<b>C</b>							197-014C TR-20C	197-016C TR-21C	197-018C TR-62C	
<b>F</b>		196-012F CR-31F		196-016F CR-12F	196-020F CR-11F	197-012F —	197-014F TR-20F	197-016F TR-21F	197-018F TR-62F	
<b>EF</b>				196-016EF CR-12EF	196-020EF CR-11EF	197-012EF —	197-014EF TR-20EF	197-016EF TR-21EF	197-018EF TR-62EF	

Round End Cone

FG 314 Shank	1.2(0.7)/8.0 22.0 198 (856)	1.4(0.8)/8.0 22.0 198 (856)	1.6(0.9)/8.0 22.0 198 (856)	1.8(1.0)/8.0 22.0 198 (856)	1.2(0.6)/10.0 22.0 199 (850)	1.4(0.7)/10.0 22.0 199 (850)	1.6(0.8)/10.0 22.0 199 (850)	1.8(0.9)/9.0 22.0 199 (850)	2.2(1.3)/9.0 22.0 199 (850)	2.2(1.3)/11.0 24.0 200 (850L)
	<b>M</b>	198-012M —	198-014M TR-25	198-016M TR-24	198-018M TR-23	199-012M —	199-014M TR-11	199-016M TR-12	199-018M TR-13	199-022M TR-14
<b>S</b>		198-014S TR-25S	198-016S TR-24S			199-014S TR-11S	199-016S TR-12S	199-018S TR-13S		
<b>C</b>		198-014C TR-25C	198-016C TR-24C	198-018C TR-23C		199-014C TR-11C	199-016C TR-12C	199-018C TR-13C	199-022C TR-14C	
<b>F</b>	198-012F —	198-014F TR-25F	198-016F TR-24F	198-018F TR-23F	199-012F —	199-014F TR-11F	199-016F TR-12F	199-018F TR-13F	199-022F TR-14F	
<b>EF</b>	198-012EF —	198-014EF TR-25EF	198-016EF TR-24EF	198-018EF TR-23EF	199-012EF —	199-014EF TR-11EF	199-016EF TR-12EF	199-018EF TR-13EF		









Round End Cone

FG 314 Shank	2.4(1.4)/11.0 24.0 200 (850L)	1.0(0.8)/2.8 19.0 233 (808)	1.4(1.1)/4.0 19.0 234 (808L)	1.8(1.3)/5.0 19.0 237 (808R)	2.1(1.6)/5.0 19.0 237 (808R)	3.2(1.8)/5.0 19.0 237 (808R)
	<b>M</b>	200-024M TR-19	233-010M EX-41	234-014M EX-31	237-018M EX-20	237-021M EX-21
<b>S</b>				237-018S EX-20S	237-021S EX-21S	
<b>F</b>			234-014F EX-31F	237-018F EX-20F	237-021F EX-21F	
<b>EF</b>			234-014EF EX-31EF	237-018EF EX-20EF	237-021EF EX-21EF	







Pear

FG 314 Shank	1.0/4.3 23.5 540 (889)	1.2/6.0 21.0 248 (861)	1.4/6.0 21.0 248 (861)	1.4/8.0 22.0 249 (862)	1.6/8.0 22.0 249 (862)	1.2/10.0 24.0 250 (863)	1.4/10.0 24.0 250 (863)	1.6/10.0 24.0 250 (863)	1.8/9.5 21.0 190 (---)
	<b>M</b>	248-012M FO-41	248-014M FO-20	249-014M FO-21	249-016M FO-22	250-012M FO-11	250-014M FO-12	250-016M FO-13	
<b>S</b>	248-012S FO-41S	248-014S FO-20S	249-014S FO-21S	249-016S FO-22S	250-012S FO-11S	250-014S FO-12S	250-016S FO-13S		
<b>C</b>			249-014C FO-21C	249-016C FO-22C	250-012C FO-11C	250-014C FO-12C	250-016C FO-13C	190-018C FO-54C	
<b>F</b>		248-012F FO-41F	248-014F FO-20F	249-014F FO-21F	249-016F FO-22F	250-012F FO-11F	250-014F FO-12F	250-016F FO-13F	
<b>EF</b>	540-010EF FO-40EF	248-012EF FO-41EF	248-014EF FO-20EF	249-014EF FO-21EF	249-016EF FO-22EF	250-012EF FO-11EF	250-014EF FO-12EF	250-016EF FO-13EF	

Flame







	 1.6/3.5 19.0 257 (368,830)	 1.8/3.6 19.0 257 (368,830)	 2.1/5.0 19.0 257 (368,830)	 2.3/5.0 19.0 257 (368,830)	 2.5/5.0 19.0 257 (368,830)	 2.8/5.0 19.0 257 (368,830)	 3.0/5.0 19.0 257 (368,830)	 3.2/5.0 19.0 257 (368,830)
FG 314 Shank								
<b>M</b>	257-016M FO-30	257-018M FO-32	257-021M —	257-023M FO-34	257-025M FO-24	257-028M FO-25	257-030M FO-26	257-032M FO-27
<b>S</b>		257-018S FO-32S	257-021S —	257-023S FO-34S	257-025S FO-24S	257-028S FO-25S	257-030S FO-26S	257-032S FO-27S
<b>C</b>		257-018C FO-32C	257-021C —	257-023C FO-34C	257-025C FO-24C	257-028C FO-25C		
<b>F</b>	257-016F FO-30F	257-018F FO-32F	257-021F —	257-023F FO-34F	257-025F FO-24F	257-028F FO-25F	257-030F FO-26F	257-032F FO-27F
<b>EF</b>	257-016EF FO-30EF	257-018EF FO-32EF	257-021EF —	257-023EF FO-34EF	257-025EF FO-24EF	257-028EF FO-25EF	257-030EF FO-26EF	257-032EF FO-27EF

Bud

	 1.6/3.2 19.0 277 (379,833)	 1.8/3.5 19.0 277 (379,833)	 2.0/3.9 19.0 277 (379,833)	 2.3/4.5 19.0 277 (379,833)	 3.0/5.0 19.0 277 (379,833)	 1.6/5.0 19.0 465 (820)	 3.1/3.5 19.0 465 (820)
FG 314 Shank							
<b>M</b>	277-016M —	277-018M —	277-020M TR-22	277-023M —	277-030M TR-28	465-016M —	
<b>S</b>			277-020S TR-22S		277-030S TR-28S		
<b>F</b>	277-016F —	277-018F —	277-020F TR-22F	277-023F —	277-030F TR-28F	465-016F —	465-031F —
<b>EF</b>	277-016EF —	277-018EF —	277-020EF TR-22EF	277-023EF —	277-030EF TR-28EF	465-016EF —	

Egg

Interdental

	 1.2/6.0 21.0 288 (867,877)	 1.2/8.0 22.0 289 (868,878)	 1.4/8.0 22.0 289 (868,878)	 1.6/8.0 22.0 289 (868,878)	 1.2/10.0 24.0 290 (869,879)	 1.4/10.0 24.0 290 (869,879)	 1.6/10.0 24.0 290 (869,879)
FG 314 Shank							
<b>M</b>	288-012M SO-20	289-012M —	289-014M SO-21	289-016M —	290-012M —	290-014M —	290-016M —
<b>S</b>			289-014S SO-21S				
<b>C</b>		289-012C —	289-014C SO-21C	289-016C —	290-012C —	290-014C —	290-016C —
<b>F</b>	288-012F SO-20F	289-012F —	289-014F SO-21F	289-016F —			
<b>EF</b>	288-012EF SO-20EF		289-014EF SO-21EF				

Torpedo

FG 314 Shank						
	298 (878K)	298 (878K)	299 (879K)	299 (879K)	115 (842SP)	178 (848SP)
<b>M</b>	298-016M —	298-018M —	299-016M —	299-018M —	115-014M BC-11	178-016M BC-12
<b>S</b>	298-016S —		299-016S —			
<b>C</b>	298-016C —	298-018C —	299-016C —	299-018C —		

Torpedo, Conical

FG 314 Shank								
	552 (834)	552 (834)	552 (834)	544 (845KR)	545 (846KR)	546 (847KR)	553 (848KR)	553 (848KR)
<b>M</b>	552-016M VP-20	552-018M VP-21	552-021M VP-22	544-018M RS-31/EX-38	545-018M RS-21/EX-29	546-016M —	553-018M —	553-019M RS-11/EX-17

Depth Marking

Taper, Round Edge

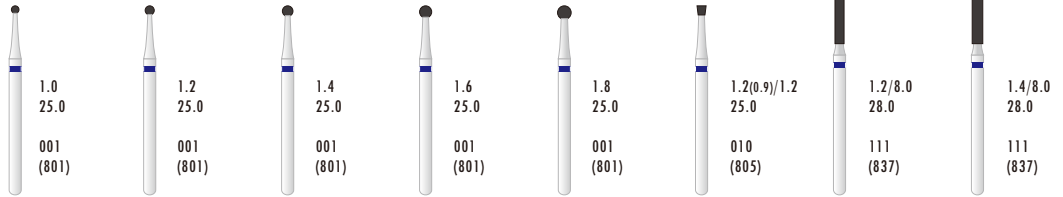
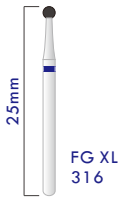

FG Surgical

**001-X010M** BR-X45    **001-X012M** BR-X46    **001-X014M** BR-X41    **001-X016M** BR-X40    **001-X018M** BR-X31    **010-X012M** SI-X46    **111-X012M** SF-X11    **111-X014M** SF-X12

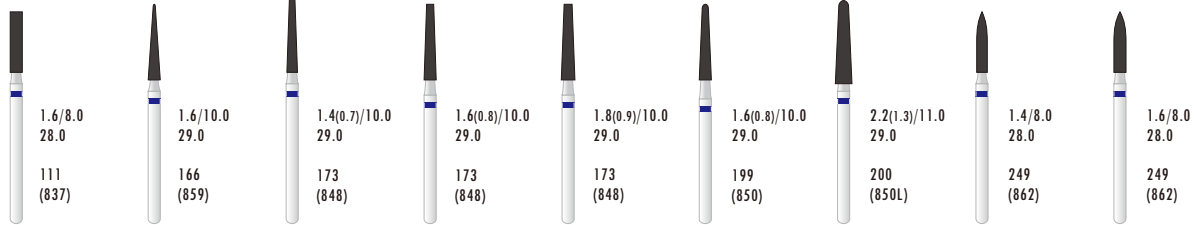

**111-X016M** SF-X13    **166-X016M** TC-X11    **173-X014M** TF-X11    **173-X016M** TF-X12    **173-X018M** TF-X13    **199-X016M** TR-X12    **200-X022M** TR-X15    **249-X014M** FO-X21    **249-X016M** FO-X22

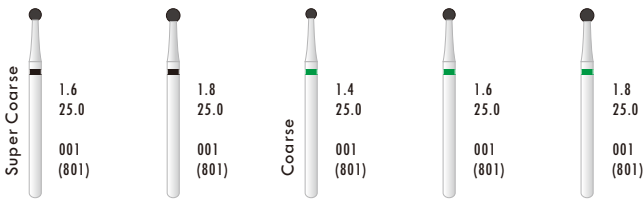

**001-X016S** BR-X40S    **001-X018S** BR-X31S    **001-X014C** BR-X41C    **001-X016C** BR-X40C    **001-X018C** BR-X31C

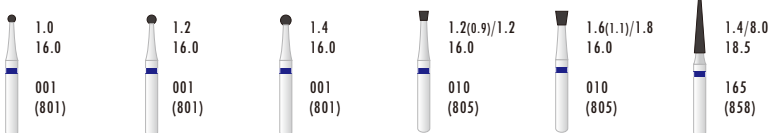
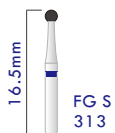

FG Short

**001-S010M** BR-S45    **001-S012M** BR-S46    **001-S014M** BR-S41    **010-S012M** SI-S46    **010-S016M** SI-S48    **165-S014M** TC-S21

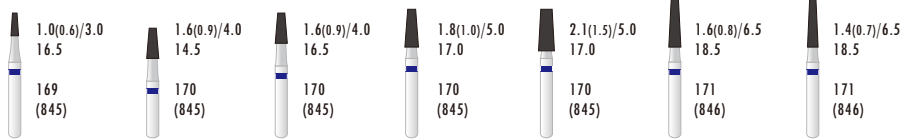

**169-S010M** TF-S41    **170-SS016M** TF-SS31    **170-S016M** TF-S31    **170-S018M** TF-S23    **170-S021M** TF-S22    **171-S016M** TF-S21    **171-S014M** TF-S20

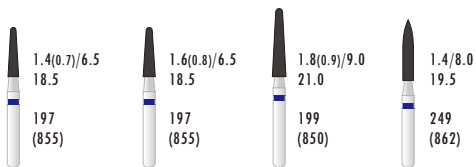

**197-S014M** TR-S20    **197-S016M** TR-S21    **199-S018M** TR-S13    **249-S014M** FO-S21



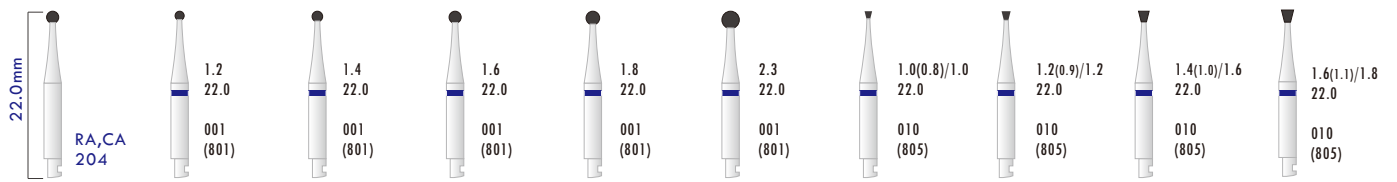

<b>M</b>	<b>001-R012M</b> BR-R46	<b>001-R014M</b> BR-R41	<b>001-R016M</b> BR-R40	<b>001-R018M</b> BR-R31	<b>001-R023M</b> BR-R26	<b>010-R010M</b> SI-R45	<b>010-R012M</b> SI-R46	<b>010-R014M</b> SI-R47	<b>010-R016M</b> SI-R48
<b>F</b>			<b>001-R016F</b> BR-R40F	<b>001-R018F</b> BR-R31F	<b>001-R023F</b> BR-R26F				
<b>EF</b>			<b>001-R016EF</b> BR-R40EF	<b>001-R018EF</b> BR-R31EF	<b>001-R023EF</b> BR-R26EF				

Ball, Round /BR

Inverted Conical / SI

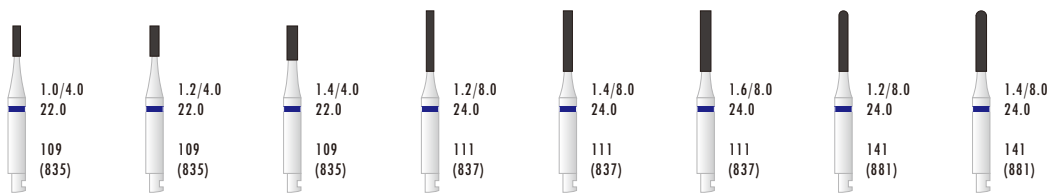

<b>109-R010M</b> SF-R41	<b>109-R012M</b> SF-R31	<b>109-R014M</b> SF-R42	<b>111-R012M</b> SF-R11	<b>111-R014M</b> SF-R12	<b>111-R016M</b> SF-R13	<b>141-R012M</b> SR-R11	<b>141-R014M</b> SR-R12
----------------------------	----------------------------	----------------------------	----------------------------	----------------------------	----------------------------	----------------------------	----------------------------

Flat End Cylinder / SF

Round End Cylinder / SR

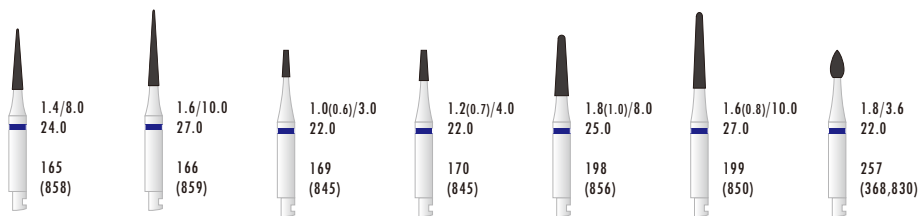

<b>M</b>	<b>165-R014M</b> TC-R21	<b>166-R016M</b> TC-R11	<b>169-R010M</b> TF-R41	<b>170-R012M</b> TF-R42	<b>198-R018M</b> TR-R23	<b>199-R016M</b> TR-R12	<b>257-R018M</b> FO-R32
<b>F</b>	<b>165-R014F</b> TC-R21F						<b>257-R018F</b> FO-R32F

Needle

Flat End Cone /TF

Round End Cone/TR

Flame / FO



## Diamond Ortho-strips

金剛石鋸弓



Creating additional space by interproximal enamel reduction (IPR) :

When opening the interdental space and reducing, finishing and polishing enamel in orthodontics, care must be taken to avoid grooves and scratches. It's important to proceed step by step, following a coarse-to-fine sequence.

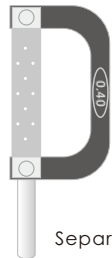

Separating

OS40

0.40 mm



Reducing

OS30

0.30 mm



Contouring

OS25

0.25 mm

Item No.  1

Thickness (mm)

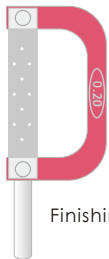

Finishing

OS20

0.20 mm

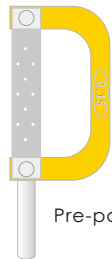

Pre-polishing

OS15

0.15 mm



Polishing

OS10

0.10 mm



No-Diamond Coated  
with serrated edge

OS05

0.05 mm

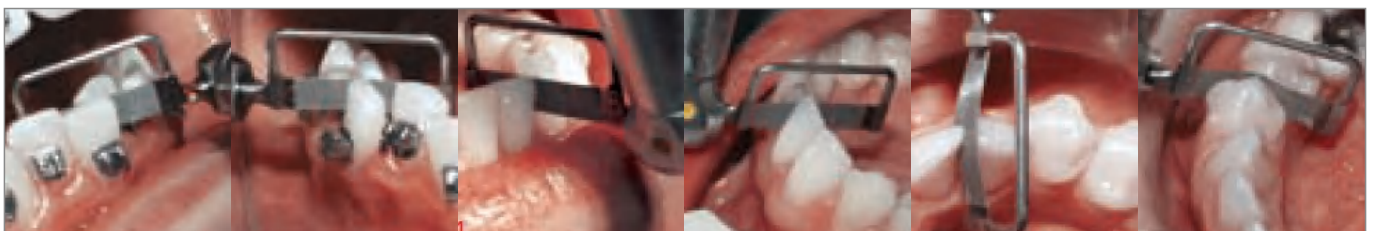

Diamond finishing strips

金刚石抛光条







Perforated Diamond finishing strips with and without serrated edge ;



Double side Coated / Single side Coated ;

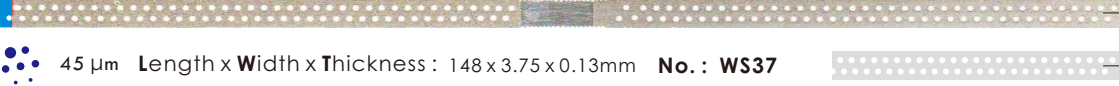

with or without honeycomb design .

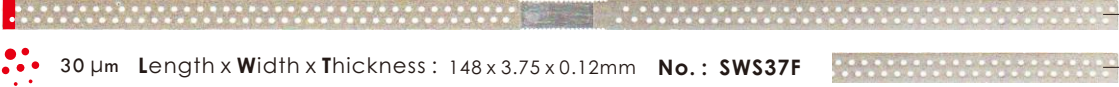

- 

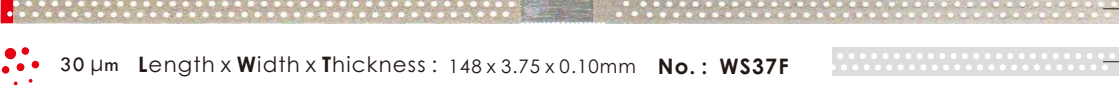

45 μm Length x Width x Thickness : 148 x 3.75 x 0.16mm No. : **SWS37**  Double side Coated
- 

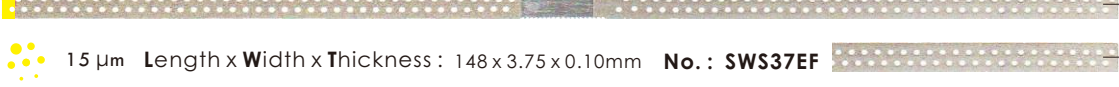

45 μm Length x Width x Thickness : 148 x 3.75 x 0.13mm No. : **WS37**  Single side Coated
- 

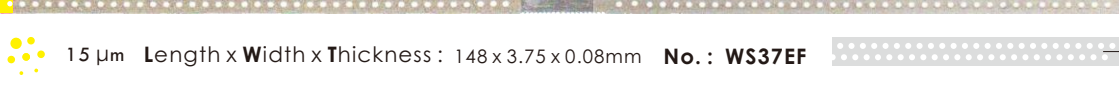

30 μm Length x Width x Thickness : 148 x 3.75 x 0.12mm No. : **SWS37F**  Double side Coated
- 

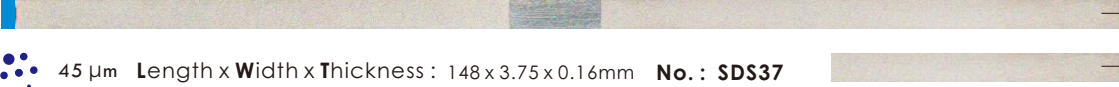

30 μm Length x Width x Thickness : 148 x 3.75 x 0.10mm No. : **WS37F**  Single side Coated
- 

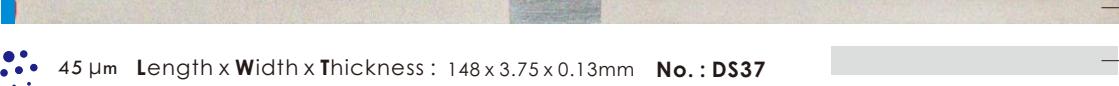

15 μm Length x Width x Thickness : 148 x 3.75 x 0.10mm No. : **SWS37EF**  Double side Coated
- 

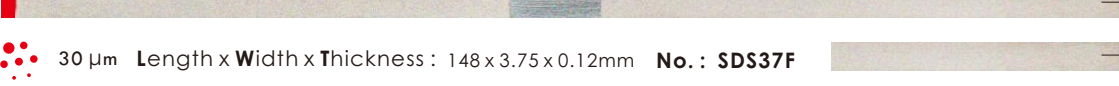

15 μm Length x Width x Thickness : 148 x 3.75 x 0.08mm No. : **WS37EF**  Single side Coated
- 

45 μm Length x Width x Thickness : 148 x 3.75 x 0.16mm No. : **SDS37**  Double side Coated
- 

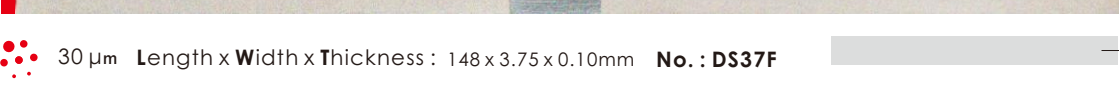
45 μm Length x Width x Thickness : 148 x 3.75 x 0.13mm No. : **DS37**  Single side Coated
- 

30 μm Length x Width x Thickness : 148 x 3.75 x 0.12mm No. : **SDS37F**  Double side Coated
- 

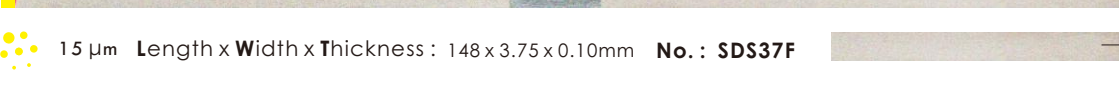
30 μm Length x Width x Thickness : 148 x 3.75 x 0.10mm No. : **DS37F**  Single side Coated
- 

15 μm Length x Width x Thickness : 148 x 3.75 x 0.10mm No. : **SDS37F**  Double side Coated
- 

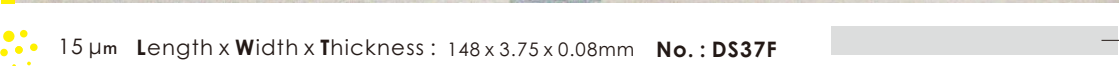
15 μm Length x Width x Thickness : 148 x 3.75 x 0.08mm No. : **DS37F**  Single side Coated



 10 pcs of each per pack  
or 10 pcs mixed 2 ● + 4 ● + 4 ●

## Tungsten Carbide Bur

钨钢车针



### Advantages

1. Strictly comply with ISO Standard
2. Sharper and More Efficient
3. Durable and Valuable
4. FG, FG Short, FG Long, RA, RA Long etc

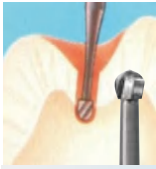
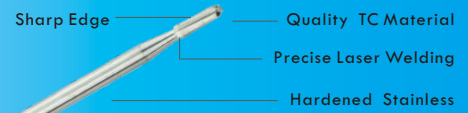

Ball, Plain Cut

ISO 500 ... 001	001	005	006	008	010	012	014	016	018	021	023	025
FG 314	FG 1/4	FG 1/2	FG 1	FG 2	FG 3	FG 4	FG 5	FG 6	FG 7	FG 8	FG 9	
FG S 313			FG S1	FG S2	FG S3	FG S4	FG S5					
FG X 316			FG X1	FG X2	FG X3	FG X4	FG X5	FG X6	FG X7	FG X8		
RA 204		RA 1/2	RA 1	RA 2	RA 3	RA 4	RA 5	RA 6	RA 7	RA 8		
RA X 205				RA X2	RA X3	RA X4	RA X5	RA X6	RA X7	RA X8		

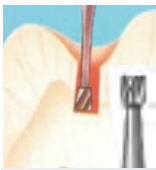

Inverted Cone

ISO 500 ... 010	001	008	010	012	014	016	018	021	023			
FG 314		FG 34	FG 35	FG 36	FG 37	FG 38	FG 39					
RA 204		RA 34	RA 35	RA 36	RA 37	RA 38	RA 39	RA 40	RA 41			



Cylinder, Plain Cut

ISO 500 ... 107	006	008	009	010	012	014	016					
Working Length/mm		4.0	4.0	4.0	4.0	4.0	4.0					
FG 314		FG 55	FG 56	FG 57	FG 58	FG 59	FG 60					
FG X 316				FG X57	FG X58							



Flat End Taper, Plain Cut

ISO 500 ... 168	006	008	009	010	012	016	009	010	012	016		
Working Length/mm		4.0	4.0	4.0	4.0	4.0	6.0	6.0	6.0	6.0		
FG 314		FG 168	FG 169	FG 170	FG 171	FG 172	FG 169L	FG 170L	FG 171L	FG 172L		
FG X 316				FG X170	FG X171							



Pear Plain Cut

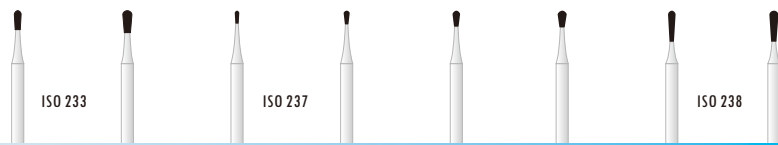

ISO 500 ... 233 001	009	012	006	008	010	012	010	012	
Working Length/mm	2.5	2.9	1.7	1.8	2.0	2.2	4.1	4.1	
FG 314	<b>FG 245</b>	<b>FG 246</b>	<b>FG 329</b>	<b>FG 330</b>	<b>FG 331</b>	<b>FG 332</b>	<b>FG 331L</b>	<b>FG 332L</b>	
FG S 313	<b>FG S245</b>								
RA 204	<b>RA 245</b>								



Cylinder, Cross Cut



ISO 500 ... 107 007	008	009	010	012	014	016	018	021	023
Working Length/mm	4.0	4.0	4.0	4.0	4.0	4.0	4.0	4.0	4.0
FG 314	<b>FG 555</b>	<b>FG 556</b>	<b>FG 557</b>	<b>FG 558</b>	<b>FG 559</b>	<b>FG 560</b>			
FG S 313		<b>FG S556</b>	<b>FG S557</b>						
FG X 316			<b>FG X557</b>	<b>FG X558</b>	<b>FG X559</b>				
RA 204		<b>RA 556</b>	<b>RA 557</b>	<b>RA 558</b>	<b>RA 559</b>	<b>RA 560</b>	<b>RA 561</b>	<b>RA 562</b>	<b>RA 563</b>
RA X 205			<b>RA X557</b>						



Cylinder, Cross Cut

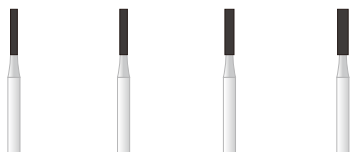



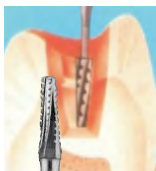



ISO 500 ... 110 007	009	010	012	014					
Working Length/mm	6.0	6.0	6.0	6.0					
FG 314	<b>FG 556L</b>	<b>FG 557L</b>	<b>FG 558L</b>	<b>FG 559L</b>					











Flat End Taper, Cross Cut





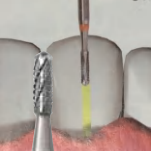













ISO 500 ... 168 007	008	009	010	012	016	021	023	009	010	012	016
Working Length/mm	4.0	4.0	4.0	4.0	4.0	4.0	4.0	6.0	6.0	6.0	6.0
FG 314	<b>FG 698</b>	<b>FG 699</b>	<b>FG 700</b>	<b>FG 701</b>	<b>FG 702</b>			<b>FG 699L</b>	<b>FG 700L</b>	<b>FG 701L</b>	<b>FG 702L</b>
FG X 316			<b>FG X700</b>	<b>FG X701</b>	<b>FG X702</b>						
RA 204		<b>RA 669</b>	<b>RA 700</b>	<b>RA 701</b>	<b>RA 702</b>	<b>RA 703</b>	<b>RA 704</b>				
RA X 205				<b>RA X701</b>							











						
ISO 500 ... 137 007	008	009	010	012	014	016
Working Length/mm	4.0	4.0	4.0	4.0	4.0	4.0
FG 314	FG 1155	FG 1156	FG 1157	FG 1158	FG 1159	FG 1160
FG S 313	FG S1157					









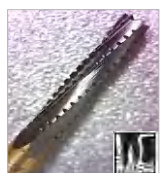

							
ISO 500 ... 194 006	009	010	012	016	ISO 500 ... 194 007	012	016
Working Length/mm	4.0	4.0	4.0	4.0	Working Length	4.0	4.0
FG 314	FG 1169	FG 1170	FG 1171	FG 1172	FG 314	FG 1701	FG 1702

				
ISO 500 ... 137 007	009	010	012	014
Working Length/mm	4.0	4.0	4.0	4.0
FG 314	FG 1556	FG 1557	FG 1558	FG 1559
FG X 316	FG X1557	FG X1558		











							
ISO 500 ...	009	012	ISO 500 ... 468 ...	014	ISO 500 ... 150 001	010	012
Working Length/mm	3.0	5.5	Working Length/mm	4.0	Working Length/mm	0.2	0.2
FG 314	ET3	ET5	FG 314	FG 468	FG 314	FG 957	FG 958









								
ISO 500 ... 237.008	010	012	ISO 500 ... 137.008	010	012	ISO 500 ... 107 008	010	012
Working Length/mm	2.0	2.2	Working Length/mm	4.0	4.0	Working Length/mm	4.0	4.0
FG 314	FG 1931	FG 1932		FG 1957	FG 1958		FG 2057	FG 2058







									
Round End Taper	151	X151	XL151	Bone Cutter	161	Bone Cutter	162	H253E	H254E
	1.6(0.9)/11 23.0 199	1.6(0.9)/11 25.0 199	1.6(0.9)/11 28.0 199		1.6(1.0)/10.0 25.0 408		1.6(1.0)/10.0 25.0 408	1.2(0.7)/6.0 28.0 415	1.2(0.7)/6.0 34.0 415

									
Flat End Taper, Cylinder	EC25	EC28	EC32	ES25	ES28	Round End Taper	152	X152	XL152
	1.6(1.2)/8.0 25.0 172	1.6(1.2)/8.0 28.0 172	1.6(1.2)/8.0 32.0 172	1.6/8.0 25.0 111	1.6/8.0 28.0 111	Endo, safe End	1.6(0.9)/9.0 21.0 210	1.6(0.9)/9.0 23.0 210	1.6(0.9)/9.0 25.0 210

## Trimming & Finishing Carbide Burs

									
Round	FG 7004	FG 7005	FG 7006	Flat End Taper	FG 7204	FG 7205	Pointed Taper	FG 7611	FG 7612
	1.4 19.0 001	1.6 19.0 001	1.8 19.0 001		1.4/9.0 23.0 184	1.6/9.0 23.0 184		1.0/4.2 19.0 159	1.4/6.0 21.0 164

								
Egg	FG 7404	FG 7406	Flat End Taper	FG 7114	FG 7214	FG 7714	Round End Taper	FG 7675
	1.4/3.3 19.0 277	1.8/3.5 19.0 277		0.9/3.5 19.0 168	1.0/5.5 21.0 170	1.4/9.0 23.0 172		1.6(1.0)/8.0 22.0 198

					
8 - 12 Blades	Flame	FG 7901	FG 7902	FG 7903	FG 7903L
		0.9/3.6 19.0 496	1.0/3.6 19.0 496	1.2/3.6 19.0 496	1.2/9.0 23.0 250



**White Stone 白车石** Finish, Polish Filling Composite 去树脂, 填充物及抛光。

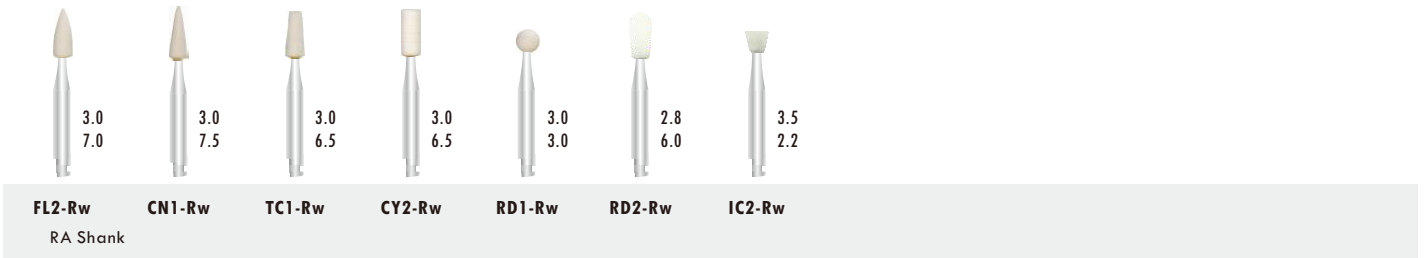
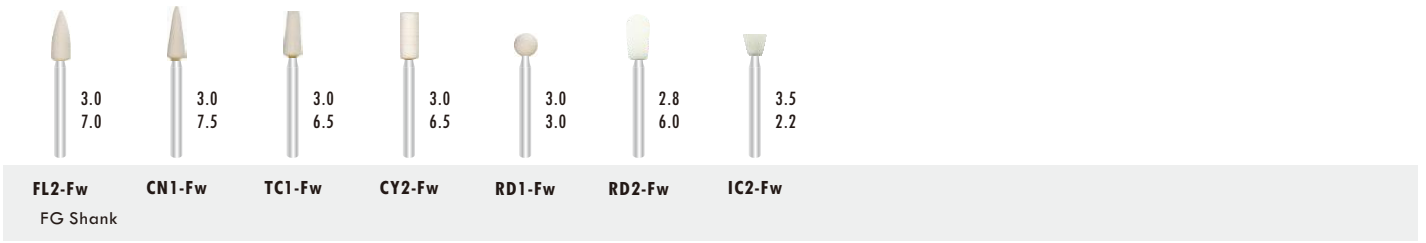

**Green Stone 绿车石** Grind Ceramics, Precious Metal 研磨烤瓷, 贵金属等。

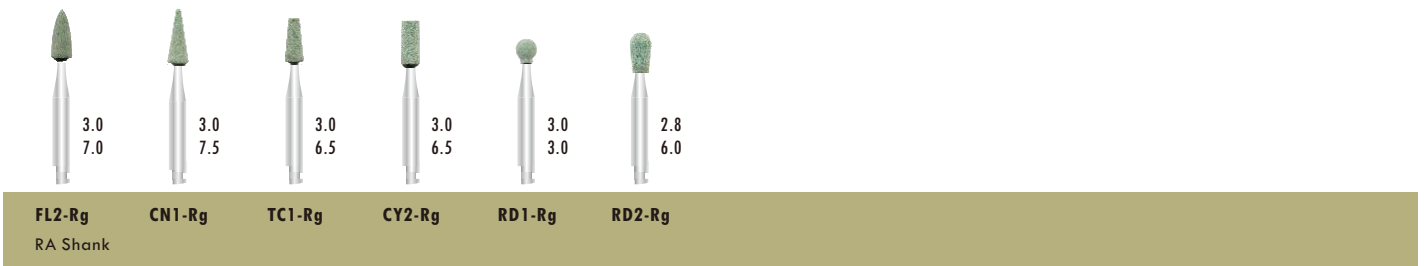
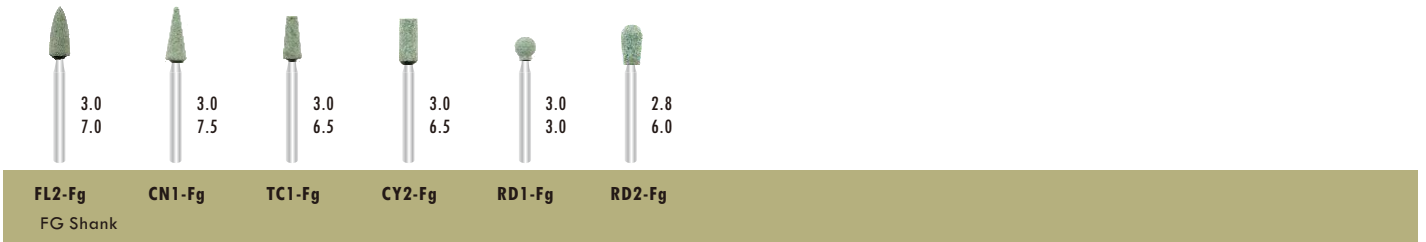

**Diamond Stones 陶瓷金刚车石** Finish Zirconia, Lithium Disilicate, Ceramics . 研磨氧化锆、玻璃陶瓷、烤瓷。

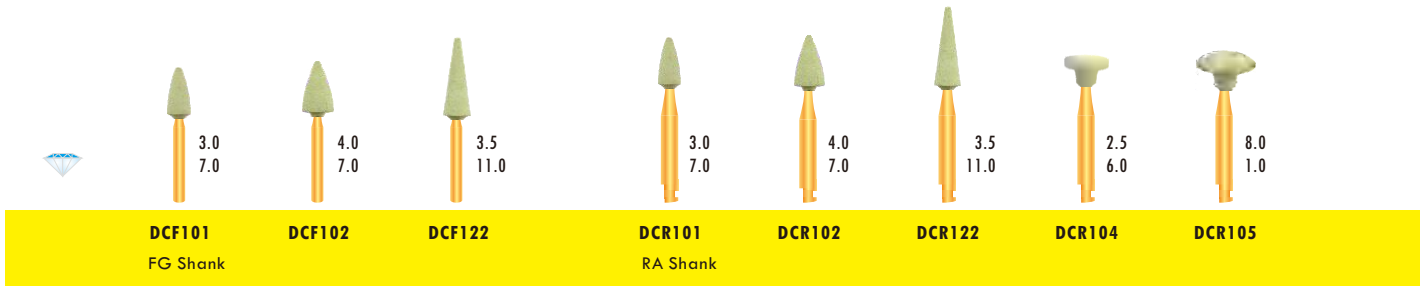

**Diamond Rubber Polishers 橡胶金刚石抛光磨头**

Universally used to polish Zirconia, Lithium Disilicate, Ceramics, Composite etc.  
广泛的用于抛光氧化锆、玻璃陶瓷、烤瓷、树脂等。

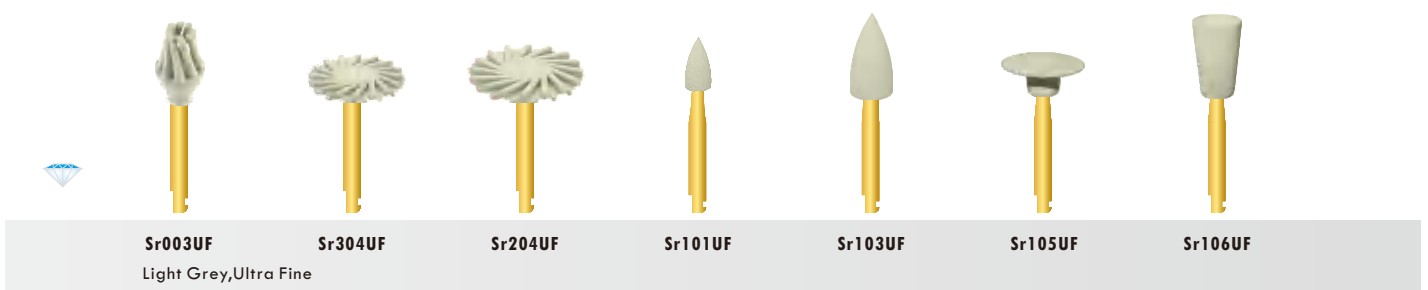
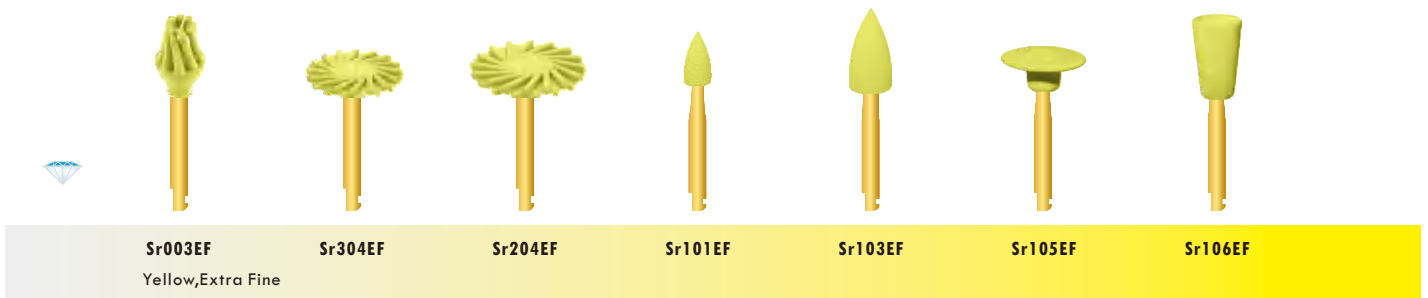
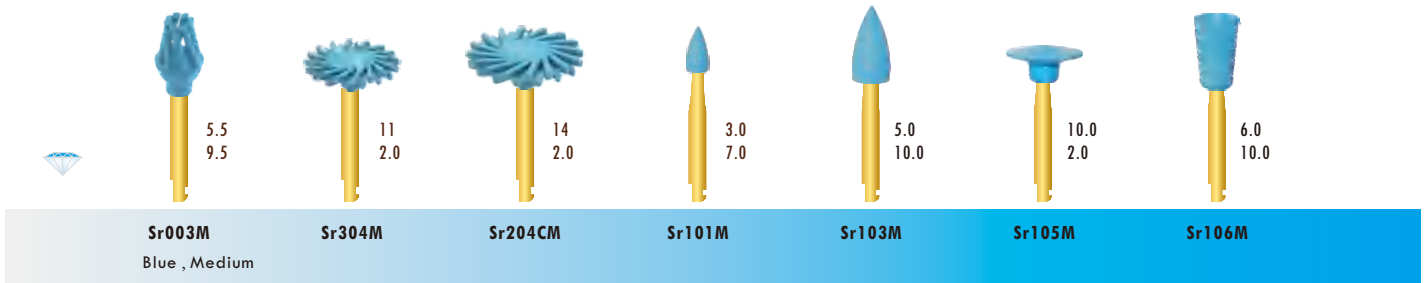

## Cleaning Burs after debonding (脱胶后)洁牙磨头

Remove Calculus or Stains , No damage to the enamel.



### Silicon 矽粒子



## Twin-Color Polishers for Composite

双色·树脂专用抛光磨头



Composite, Acrylic teeth's Polishing,  
Polishing after remove Calculus or Stains , No damage to  
the enamel.  
Polishing after remove the debonding

Item No.  12



Tr103C



Tr104C



Tr105C



Tr106C

Thickness (mm)

5 x 10.5mm

10 x 1 mm

10 x 2.0 (0.7) mm

6 x 8 mm

Item No.  12



Tr103M



Tr104M



Tr105M



Tr106M

Thickness (mm)

5 x 10.5mm

10 x 1 mm

10 x 2.0 (0.7) mm

6 x 8 mm

Item No.  12



Tr103F



Tr104F



Tr105F



Tr106F

Thickness (mm)

5 x 10.5mm

10 x 1 mm

10 x 2.0 (0.7) mm

6 x 8 mm

### Silicon Polisher

For Ceramics

硅胶磨头  
烤瓷抛光

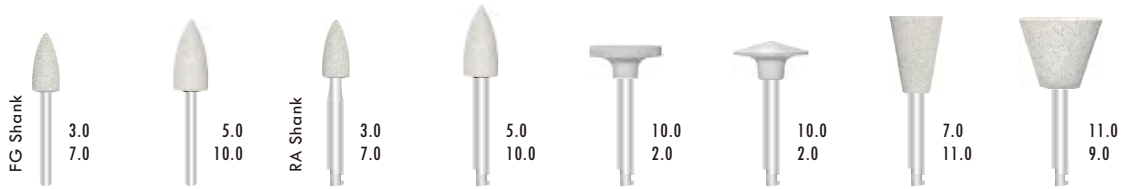

White, Coarse

Cf101C

Cf103C

Cr101C

Cr103C

Cr104C

Cr105C

Cr106C

Cr108C

### Silicon Polisher

For Ceramics

硅胶磨头  
烤瓷抛光



Pink, Medium

Cf101M

Cf103M

Cr101M

Cr103M

Cr104M

Cr105M

Cr106M

Cr108M

### Silicon Polisher

For Ceramics, Composite

硅胶磨头  
烤瓷、树脂抛光



Blue, Fine

Cf101F

Cf103F

Cr101F

Cr103F

Cr104F

Cr105F

Cr106F

Cr108F

### Silicon Polisher

For Metal, Alloy

硅胶磨头  
金属、合金抛光



Black, Coarse

Af101C

Af103C

Ar101C

Ar103C

Ar104C

Ar105C

Ar106C

Ar108C

### Silicon Polisher

For Metal, Alloy

硅胶磨头  
金属、合金抛光



Brown, Medium

Af101M

Af103M

Ar101M

Ar103M

Ar104M

Ar105M

Ar106M

Ar108M

### Silicon Polisher

For Metal, Alloy,  
Composite

硅胶磨头  
金属、合金、树脂抛光



Fine, Light Grey

Af101F

Af103F

Ar101F

Ar103F

Ar104F

Ar105F

Ar106F

Ar108F

### Silicon Polisher

For Composite

硅胶磨头  
树脂抛光



Fine, Yellow

Rf101F

Rf103F

Rr101F

Rr103F

Rr104F

Rr105F

Rr106F

Rr108F

## Polishing Brushes

Nature Material, No hurt to teeth  
Final polishing composite,  
nature teeth or Ceramics  
天然毛质、不伤牙  
适用于树脂、真牙、烤瓷等



Felt  
毛毡

R1Ns



Leather  
羊皮

R1Ry



Goat Hair  
羊毛

R1G



Thread  
白棉线

R1T

## Polishing Brushes

Abrasive Fiber  
磨料丝 (含碳化硅  
或氧化铝)

For Composite,  
Ceramics

With Al<sub>2</sub>O<sub>3</sub>



R1AI



R4AI



R5AI



R7AI

With Silicon Carbide



R1SiC



R4SiC



R5SiC



R7SiC



White Bristle

R4Dw



White Nylon

R4Cw



Clear Nylon

R4Cc



Blue Nylon

R4Cb



Pink Nylon

R4Cr



Purple Nylon

R4Cp



Yellow Nylon

R4Cy



White Goat Hair

R4G

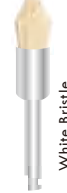

White Bristle

R7Dw

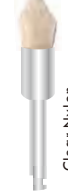

Clear Nylon

R7Cc



White Goat Hair

R7G



White Bristle

R5Dw



White Nylon

R5Cw



Clear Nylon

R5Cc



Blue Nylon

R5Cb



Pink Nylon

R5Cr



Purple Nylon

R5Cp



Yellow Nylon

R5Cy



White Goat Hair

R5G



4 Angles, Soft

R01W



6 Angles, Hard

R02W

## Mandrels

夹 针



31RS



31RSL  
RA X Long shank



35RS



52RS



53RS



26RS  
Adapter FG into RA



51R  
Disposable use  
made of steel



No. 201  
for FG burs \* 15



No. 211  
for 10\*FG + 5\*RA



No. 221  
for 5\*FG + 10\*RA



No. 241  
for RA burs \* 12



No. 202  
for Root canal files \* 18



No. 212  
For HP burs \* 18



No. 015A  
for 18\*FG



No. 015C  
for 12\*FG + 6\*RA



No. 015E  
for 18\*RA



No. 015D  
for 20\*FG + 10\*RA



No. 013E  
for 16\*FG + 9\*RA



No. 022D  
for 18\*RA



No. 016B  
for 8\*HP



No. 023  
132 \* 107 \* 65 mm  
for FG, RA, HP, Files Mixed

## Alluminum Blocks, Sterilisable

铝制消毒盒

## Plastic Blocks, Sterilisable

塑料消毒盒



# KIT 套装

Provide kinds of kits for clinic use , which offer the smartest operation ;  
 Whatever for Ceramics, Zirconia , Lithium Disilicate, Composite, Metal or Alloy ;  
 From Preparation to Final polishing ;  
 High Efficiency to shining, No need Glaze after polishing .



### BR1901

BR-49, BR-45, BR-46, BR-41, BR-40,  
 BR-31, BR-28, BR-26, BR-25, BR-23 .

Diamond burs of Ball shape Assorted in FG shank  
 圆球状金刚石车针混装(高速)



### BR1902

BR-X45, BR-X46, BR-X41, BR-X40, BR-X31,  
 BR-X40S, BR-X31S, BR-X41C, BR-X40C, BR-X31C

Diamond burs of Ball shape Assorted in FG LONG  
 圆球状金刚石车针混装(高速加长)



### BR1903

BR-R46, BR-R41, BR-R40, BR-R31, BR-R26,  
 BR-R40F, BR-R31F, BR-R26F, BR-R40EF, BR-R26EF

Diamond burs of Ball shape Assorted in RA shank  
 圆球状金刚石车针混装(低速)

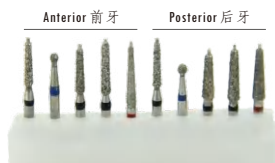

### 4100

508T-014S, BR-41, 198-016S, 508T-016S, 508T-016F ;  
 508T-014S, BR-540, 198-021S, 508T-021S, 508T-021F

Safe End Diamond Preparation  
 前后牙预备(安全端金刚石车针)



### 4101

TF-21, TF-10, TF-12, TC-10, WR-13  
 SR-11, TR-11, EX-18, TR-12F, TC-11F

Crown & Bridge Preparation for Anterior  
 前牙桥体/冠体预备

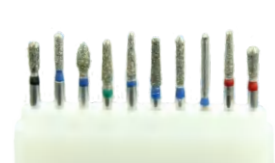

### 4102

EX-20S, SR-21, FO-34, TR-62C, TR-21  
 TR-24, SO-21, EX-18, TR-21F, EX-21F

Crown & Bridge Preparation for Posterior  
 后牙桥体/冠体预备



### 18041V

SI-45 x 2 ; SI-46 x 3,  
 SI-47 x 3, SI-48 x 2 .

Diamond burs of Inverted Cone Assorted in FG shank  
 常用倒锥金刚石车针混装(高速)



### 1805TA

TR-11 x 2, TR-12 x 2, TF-11 x 2 ;  
 TF-12, TC-10, TC-27, TC-28 x 1

Regular Diamond burs of Taper Assorted in FG shank  
 常用锥形金刚石车针混装 (高速)

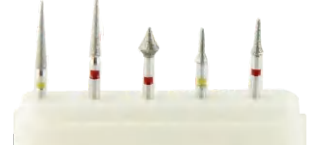

### 1806

TC-11EF, 820-016EF, 820-031F,  
 820-016F, TC-10F

Interproximal Enamel Reduction (IPR) for Ortho  
 邻面去釉套装

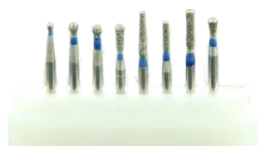

### 4103

BR-45, BR-40, BC-32, EX-31  
 TF-20, SF-41, SF-21, SI-48

Cavity Preparation, Restoratives  
 备洞



### 4104

SI-48, DI-42, TF-31, TF-22, SF-21  
 EX-18, TF-21F, SF-21F, FO-22EF, EX-21EF

Inlay & Onlay Preparation  
 嵌体/高嵌体预备



### 4105

BR-49, SF-41, SR-41, TC-26, CR-41  
 EX-41, FO-40EF / FG1/4, FG1/2, FG 1

Micro Invasive Surgery  
 微创备牙



**6000**

BR-45, VP-20, VP-21, VP-22,  
SR-41, TR-25, SO-20, TR-13F, CF101F

Porcelain Veneers' Preparation  
瓷贴面备牙套装



**6002**

CD-50F, CD-51F, CD-52F, CD-53F, CD-54F  
CD-55F, CD-56F, CD-57F, CD-58F, CD-59F

Children's Teeth Preparation  
儿童牙预备



**4106**

BR-40EF, TC-11EF, TF-11EF, TF-12EF, TR-11EF,  
EX-21EF, FO-40EF, FO-21EF, FO-22EF, FO-30EF

Ceramics / Composite Polishing  
烤瓷牙/复合树脂抛光



**FG008D**

BR-49, BR-49, SI-49, SF-49, TF-49

Student or Beginner's Diamond FG 0.8mm  
新手入门金刚石车针,高速

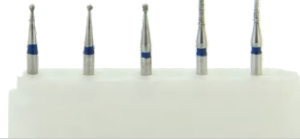

**FG009D**

001-009M, 001-009M, 010-009M,  
109-009M, 170-009M

Student or Beginner's Diamond FG 0.9mm  
新手入门金刚石车针,高速



**RA008D**

BR-R49, BR-R49, SI-R49, SF-R49, TF-R49

Student or Beginner's Diamond RA 0.8mm  
新手入门金刚石车针,慢速



**RA009D**

001-R009M, 001-R009M, 010-R009M,  
109-R009M, 170-R009M

Student or Beginner's Diamond RA 0.9mm  
新手入门金刚石车针,慢速



**TF7100**

7004, 7404, 7214, 7714, 7903L

TC Trimming & Finishing burs, F6  
钨钢精修车针, FG

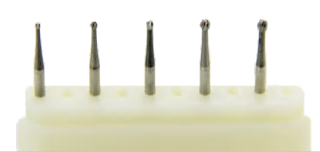

**1900 T**

FG 1, FG 2, FG 3, FG 4, FG 5

Tungsten carbide burs of Ball shape Assorted in FG shank  
圆球状钨钢车针混装(高速)



**FG008T**

FG 1, FG 1, FG 34, FG555, FG698

Tungsten Carbide of FG shank 0.8mm for Students  
初学者用的钨钢车针 (头径0.8mm, 高速)

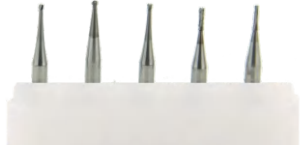

**RA008T**

RA 1, RA 1, RA 34, RA 555, RA 698

Tungsten Carbide of RA shank 0.8mm for Students  
初学者用的钨钢车针 (头径0.8mm, 低速)



**7109FW**

FL2-Fw, CN1-Fw, RD1-Fw, RD2-Fw, TC1-Fw,

FG White Stone Burs, to Finish Composite  
白车石, 高速



**7109RW**

FL2-Rw, CN1-Rw, RD1-Rw, RD2-Rw, TC1-Rw,

RA White Stone Burs, to Finish Composite  
白车石, 低速



**7109FG**

FL2-Fg, CN1-Fg, RD1-Fg, RD2-Fg, TC1-Fg,

FG Green Stone burs, Finish Ceramics  
绿车石, 高速



**7109RG**

FL2-Rg, CN1-Rg, RD1-Rg, RD2-Rg, TC1-Rg,

RA Green Stone burs, Finish Ceramics  
绿车石, 低速



**1906**

Cr103C x 2, Cr104C, Cr106C, Cr103M, Cr104M, R4AL, R5AL; R4Cb, R5Cb, R4Cr, R5Cr

**Composite Finish and Polish RA**  
树脂成型和抛光,弯机柄



**1907**

Cr103C, Cr104C, Cr106C; Cr103M, Cr104M, Cr106M, R4AL, R1AL, R5AL; R1Ry, R1G, R1T

**Composite Finish and Polish RA**  
树脂成型和抛光,弯机柄



**QR2101**

2 step : Sr003F : Pro-Polishing  
Sr003UF : Polishing

**Composite Polish, RA**  
树脂抛光,弯机柄



**QR2102**

2 step : Sr304F : Pro-Polishing  
Sr304UF, Sr003UF : Polishing

**Composite Polish, RA**  
树脂抛光,弯机柄



**QR2103**

3 step : Sr304CM : Smooth;  
Sr003F : Pro-Polishing; Sr003UF : Polishing

**Composite Polish, RA**  
树脂抛光,弯机柄



**QR2104**

3 step : Sr003M : Smooth;  
Sr003F : Pro-Polishing; Sr003UF x 2 : Polishing

**Composite Polish, RA**  
树脂抛光,弯机柄



**CP 6011**

2 Step : Sr 204 M x 3 : Pro-polish;  
Sr 204 F x 3 : Polish

**Composite, Ceramic, Zirconia Polishers . RA**  
树脂、烤瓷、氧化锆抛光



**CP 6001**

3 Step: Sr 204 C x 2 : Smooth;  
Sr 204 M x 2 : Pro-polish; Fine : Sr 204 F x 2 : Polish

**Composite, Ceramic, Zirconia Polishers . RA**  
树脂、烤瓷、氧化锆抛光



**7115**

Smooth : DCR101, DCR102, DCR122, DCR105  
Pro-polish: Sr101F, Sr103F, Sr105F, Sr106F  
Polish: Sr101UF, Sr103UF, Sr105UF, Sr106UF

**Diamond stones & polishers for Zirconia / Lithium Disilicate, 氧化锆、玻璃陶瓷研磨抛光**



**1904**

X151, XL151, EC25, EC28, FG X6,  
EX-28, BR-X31, TR-X12, TR-X15, TF-X13

**Extraction Burs**  
拔阻生齿车针



**1905**

FG X2, FG X4, FG X6, FG X558, FG X701,  
BR-X41, BR-X40, BR-X31, TF-X12, TR-X12

**Oral Surgery burs FG Long**  
手术车针(高速加长)



**4110V**

Smooth: Rw01, Rw02 x 2  
Pro-polish: Cr101M, Cr103M, Cr104M, Cr106M,  
Polish: Cr101F, Cr103F, Cr104F, Cr106F

**Composite Finish and Polish RA**  
树脂成型和抛光,弯机柄



**4112**

Smooth: Cr101C, Cr103C, Cr104C, Cr106C  
Pro-polish: Cr101M, Cr103M, Cr104M, Cr106M  
Polish: Cr101F, Cr103F, Cr104F, Cr106F

**Porcelain / Natural Teeth Polishing RA**  
烤瓷牙,自然牙抛光,弯机柄

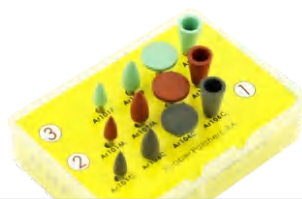

**4114**

Smooth: Ar101C, Ar103C, Ar104C, Ar106C  
Pro-polish: Ar101M, Ar103M, Ar104M, Ar106M  
Polish: Ar101F, Ar103F, Ar104F, Ar106F

**Amalgam / Metal Polishing RA**  
银汞合金,金属抛光,弯机柄



**4115**

Smooth : Sr103M, Sr105M, Sr106M ; Pro-polish : Sr103F, Sr105F, Sr106F  
Polish : Sr101EF, Sr103EF, Sr105EF, Sr106EF,  
Final Polish: Sr101UF, Sr103UF

**Diamond Polishers for Zirconia / Lithium Disilicate**  
氧化锆、玻璃陶瓷抛光,弯机柄

Crown & Bridge Preparation for Anterior  
前牙桥体/冠体预备



4101A

TF-21, TF-10, TF-12 x 2, WR-13, TC-21,  
TR-11, TC-10/EX-18, SR-11/TR-12F, TC-11F

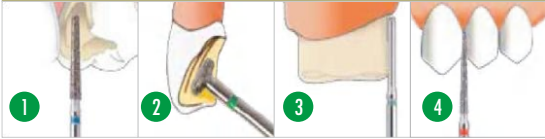

Crown & Bridge Preparation for Posterior  
后牙桥体/冠体预备



4102A

EX-11, EX-20S, TR-22S, BR-31C, TR-62C, FO-34/  
TR-24, TR-21/EX-18, SO-21/EX-21F, TR-21F

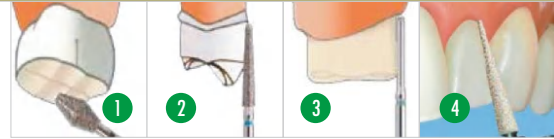

Cavity Preparation, Restoratives  
备洞



4103A

BR-45, BR-40, BR-46, BR-31, BR-41/BC-32,  
SI-47, SI-48/SF-41, SF-21/EX-31, TF-20

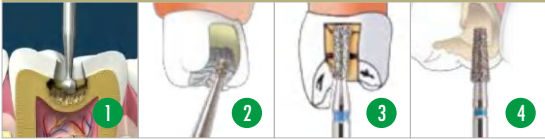

Inlay/Onlay Preparation  
嵌体/高嵌体预备



4104A

DI-42, SI-48, TF-22, TF-31 / TF-21F, SF-21F /  
TF-21, SF-21, EX-18, BC-32 / EX-21EF, FO-22EF

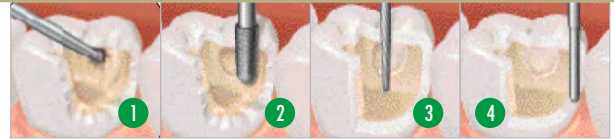

Porcelain Veneer's Preparation  
瓷贴面备牙



6000A

SR-41, BR-45 / VP-20 x 2, VP-21 x 2, VP-22 x 2/  
SO-20, TR-25, TR-13F, TC-28EF

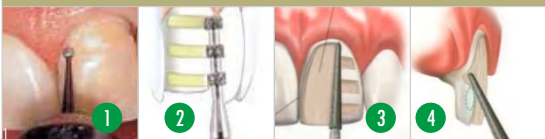

Trimming & Finishing Tungsten  
Carbide burs FG 钨钢精修车针



6003A

7004, 7005, 7006, 7404, 7406, 7114,  
7214, 7714, 7901, 7902, 7903, 7903L





Zirconia, Lithium Disilicate Polishing kit, RA  
氧化锆, 玻璃陶瓷抛光(低速)



**7115A**

Smooth : DCR101 , DCR102 , DCR122, DCR105 ; Pro-polish: Sr101F, Sr103F, Sr105F, Sr106F  
Polish: Sr101UF, Sr103UF, Sr105UF, Sr106UEF



Zirconia, Lithium Disilicate High Gloss polishing kit, RA  
氧化锆抛光(低速)



**4115A**

Smooth : Sr103M, Sr105M, Sr106M ; Pro-polish : Sr103F, Sr105F, Sr106F  
Polish: Sr101EF, Sr103EF, Sr105EF, Sr106EF, Final Polish: Sr101UF, Sr103UF



Composite or filling material Polisher RA  
美学树脂、填充材料抛光



**CP6001A**

3 Step: Sr 204 C x 2 : Smooth;  
Sr 204 M x 2 : Pro-polish ; Fine : Sr 204 F x 2 : Polish



Composite Polishing kit , RA  
树脂抛光套装(低速)



**4110A2**

Smooth: FL2-Rwx 2 , CN1-Rw x 2 ; Pro-polish: Cr101M, Cr103M, Cr104M, Cr106M,  
Polish: Cr101F, Cr103F, Cr104F, Cr106F



Ceramics / Porcelain Teeth Polish , RA  
烤瓷牙抛光(低速)



**4112A**

Smooth: Cr101C, Cr103C, Cr104C, Cr106C  
Pro-polish : Cr101M, Cr103M, Cr104M, Cr106M  
Polish: Cr101F, Cr103F, Cr104F, Cr106F

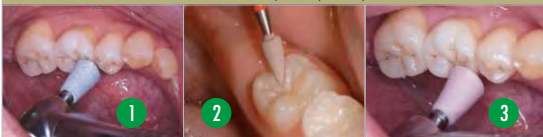

Amalgam, Alloy, Metal Polish , RA  
银汞合金抛光(低速)



**4114A**

Smooth : Ar101C, Ar103C, Ar104C, Ar106C  
Pro-polish : Ar101M, Ar103M, Ar104M, Ar106M  
Polish: Ar101F, Ar103F, Ar104F, Ar106F



Micro Invasive Surgery Burs  
微创手术用车针

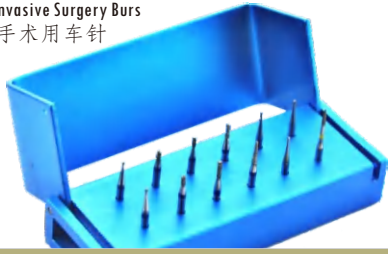

**4105A**

BR-49 x 2, SR-41 x 2, SF-41, EX-41, TC-26,  
CR-41, FG1/4, FG1/2, FG 1, FO-40EF

Extra Fine Diamond burs for polishing  
特细粒度金刚砂抛光车针,高速



**4106A**

CR-11EF, BR-40EF, TC-27EF, TC-11EF, TF-12EF, TF-11EF,  
FO-40EF, TR-11EF, FO-22EF, FO-21EF, FO-30EF, EX-21EF

Composite, Ceramics Finishing kit, FG  
树脂成型(高速)



**0302A**

FL2-Fw x 3 ; CN1-Fw x 3  
FL2-Fg x 3 ; CN1-Fg x 3

Composite, Ceramics Finishing kit, RA  
树脂成型(低速)



**0306A**

FL2-Rw x 3 ; CN1-Rw x 3  
FL2-Rg x 3 ; CN1-Rg x 3

White Stone Burs kit, FG  
白车石(高速)



**302F1**

FL2-Fw x 2, CN1-Fw x 2, RD1-Fw x 2  
RD2-Fw x 2, TC1-Fw x 2, IC2-Fw x 2

White Stone Burs kit, RA  
白车石(低速)



**306R1**

FL2-Rw x 2, FL3-Rw x 2, CN1-Rw x 2,  
RD1-Rw x 2, RD2-Rw x 2, TC1-Rw x 2 .

HP Kit to adjust Zirconia  
氧化锆修整椅旁套装(HP)



**Z31**

ZF33, DY001EF to Smoothing  
D203F for Pre-polishing ; D203EF for Polishing

HP Kit to adjust Lithium Disilicate  
玻璃陶瓷修整椅旁套装(HP)



**L31**

ZF33, DY001EF to Smoothing  
D203F for Pre-polishing ; D203UF for Polishing

Samples Collection  
For Clinic Items

样品册



Flip-Cart Plastic Pages ;  
Smart, Easily fill all burs ;  
Economic and Recyclable ;  
Nice-looking for showing to Customers ;  
Convenient to take to anywhere .



No. 170B5

Empty Collection Wallet  
样品本(不带车针)



4 Colors Available ,  
100 holes per page,  
5 pages per set,  
Smart to FG or RA Burs



No. 1701D

Diamond Burs Collection Wallet  
金刚石车针样品本



More than 300 specification ,  
Diamond burs ,  
FG, FG XL, FG 2XL,  
FG Short, RA, RA Long



No. 1702T

Tungsten Carbide Collection Wallet  
钨钢车针样品本



Nearly 200 specification ,  
TC burs  
FG, FG XL, FG Short, RA, RA Long  
T & F Gold, Endo z etc.



No. 1703P

Polishing burs Collection Wallet  
抛光器械样品本



Nearly 150 specifications ,  
Silicon Rubber burs,  
Diamond Abrasives & polishers,  
Polishing brushes etc



Four Colors Available

Brown

Black

Blue

Yellow







**Laboratory Part**  
技工类

Page 33-66 第33-66页



**Diamond bur 金刚石磨头**

Page 34-35 第34-35页

**Fully-sintered Diamond bur**  
全砂烧结磨头

Page 36-37 第36-37页

**Sintered Diamond Disc**  
**Diamond Disc**

烧结切片、金刚石切片

Page 38-40 第38-40页

**CAD / CAM Milling Bur**  
铣刀

Page 41-43 第41-43页

**Tungsten Carbide bur**  
钨钢车针

Page 44-47 第44-47页

**Diamond Stones & Polisher**  
陶瓷(橡胶) 结合剂金刚石磨头  
(全瓷、全锆磨头)

Page 48-52 第48-52页

**Silicon Polisher**  
硅胶抛光磨头

Page 53-54 第53-54页

**Mounted stone, Sandpaper**  
车石、砂纸棒

Page 55 第55页

**Polishing Brushes, Felt burs**  
**Mandrels**

抛光刷、毛毡磨头、夹针

Page 56-58 第56-58页

**Hard Z Cutter etc .**  
硬锆磨头等

Page 59 第59页

**Kit 套装**

Page 60-62 第60-62页

**Samples Collection**  
样品册

Page 63 第63页

**FlexSoft Partial Denture**  
隐形义齿胶

Page 64 第64页

**Diamond Bur HP  
(Electroplated)  
金钻石磨头 (电镀)**



Sharp and Durable,  
Grind or polish Ceramics  
锋利、耐用  
磨削平稳、不偏摆  
不留黑印、适合车瓷



**Grit**

- Black / Super Coarse
- Green / Coarse
- Blue / Medium
- Red / Fine

**Fine Red  
细砂  
红圈**



编号 No. FD30 FK33 FA23 FA33 FC18 FC25 FM27 FL33 FN23 FP33

This grit can grind Zirconia 可用于车氧化锆

**Medium Blue  
标准砂  
蓝圈**

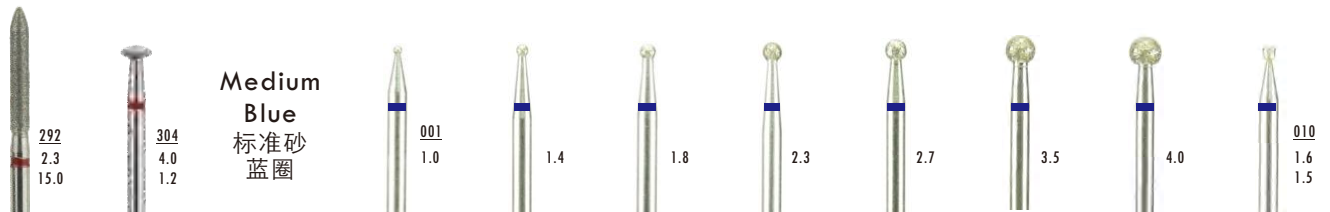

FQ23 FU40 编号 No. MD10 MD14 MD18 MD23 MD27 MD35 MD40 MK16

Round / 圆球

Inverted Cone

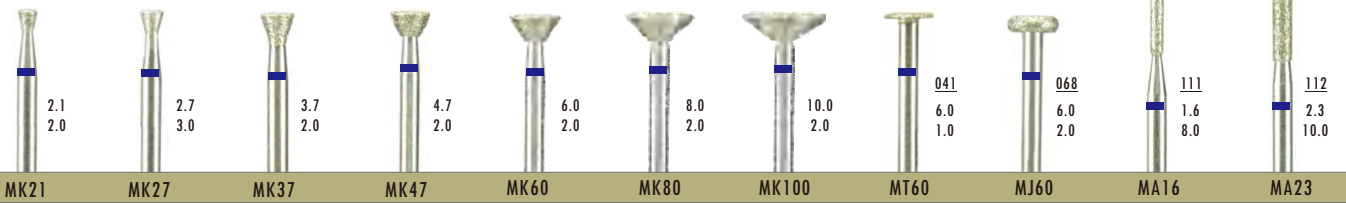

MK21 MK27 MK37 MK47 MK60 MK80 MK100 MT60 MJ60 MA16 MA23

Wheel / 平轮

Cylinder / 平柱

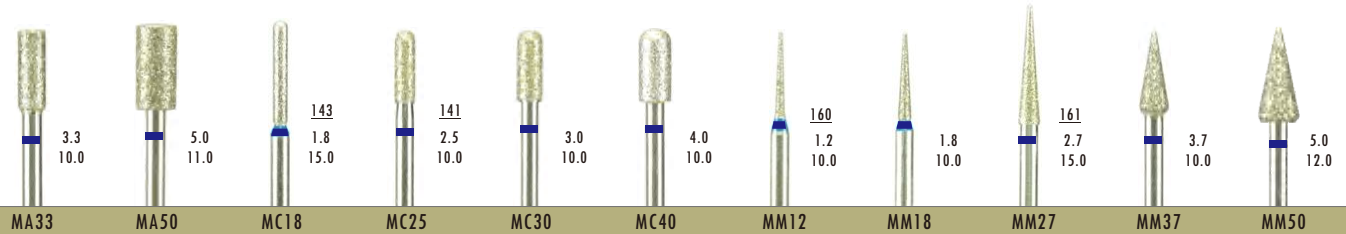

MA33 MA50 MC18 MC25 MC30 MC40 MM12 MM18 MM27 MM37 MM50

Round Cylinder / 圆头柱

Needle / 尖针

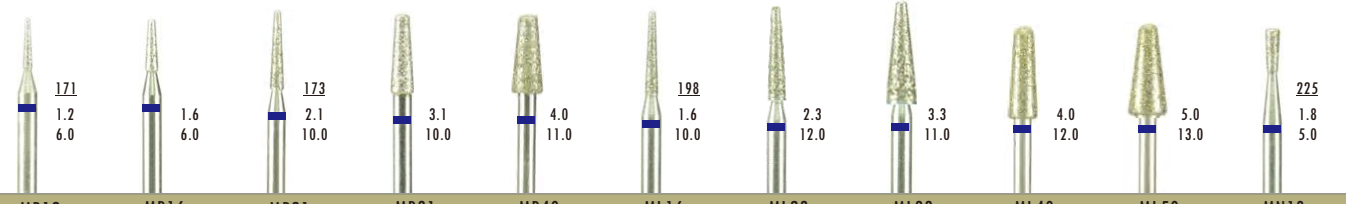

MB12 MB16 MB21 MB31 MB40 ML16 ML23 ML33 ML40 ML50 MN18

Taper / 平锥

Round Taper / 圆头锥

Inverted Cone

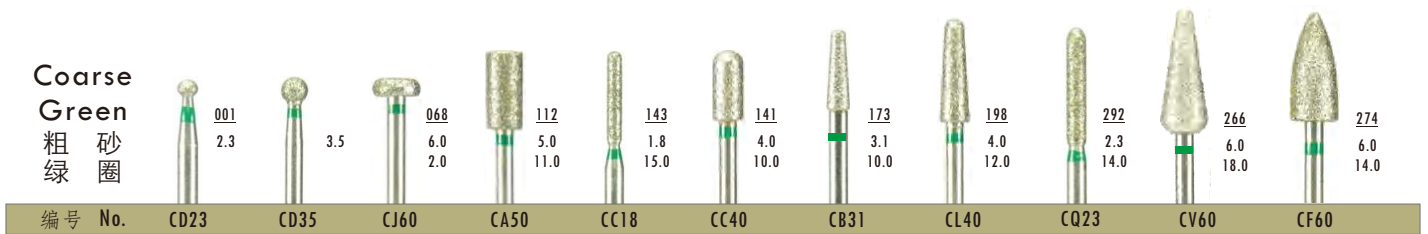
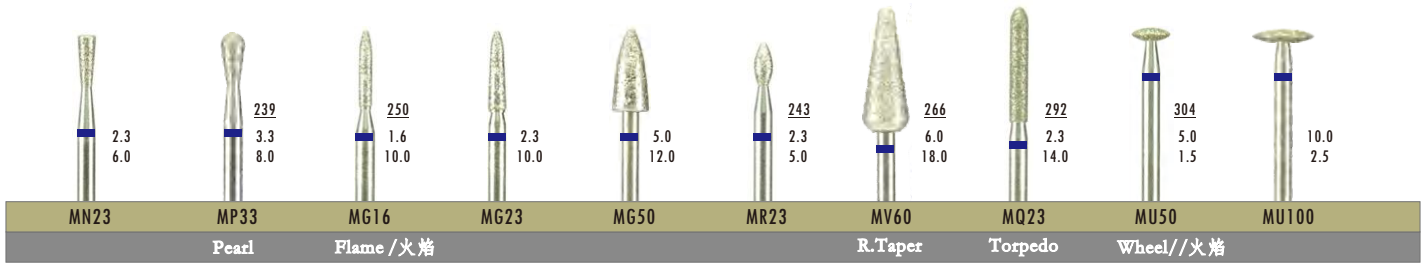

Transparent Showing plates  
展示台 120x120x8mm



No. 1216  
7 x 7 holes  
1.60mm, for FG burs

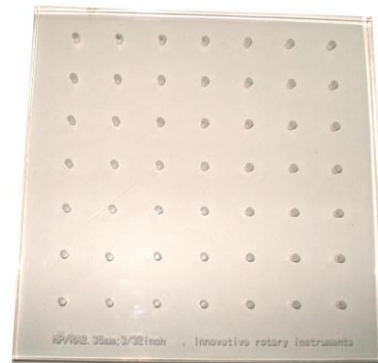

No. 1223  
7 x 7 holes  
2.35mm, for RA or HP burs.

# Fully-Sintered Diamond Bur . HP

全砂烧结磨头



Extremely Durable,  
Grind or polish smoothly  
Especial for Metal

从里到外都是砂  
平稳、耐用，适合车金

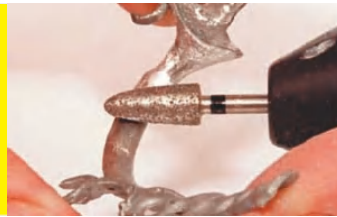

## Grit

- Black/Super Coarse
- Green/Coarse
- Blue/Medium
- Red/Fine
- Yellow/Extra Fine

### Super Coarse Black 特粗砂黑圈

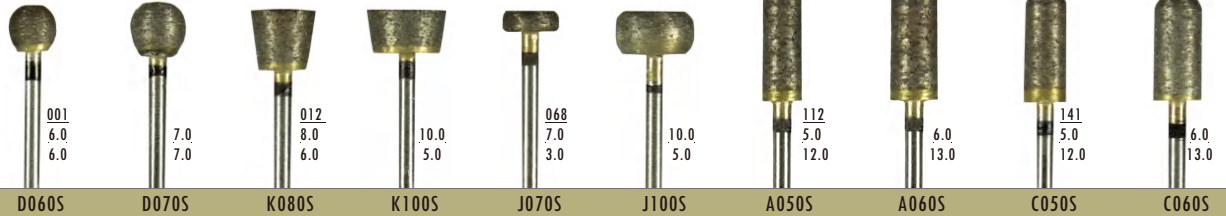

### Coarse Green 粗砂绿圈

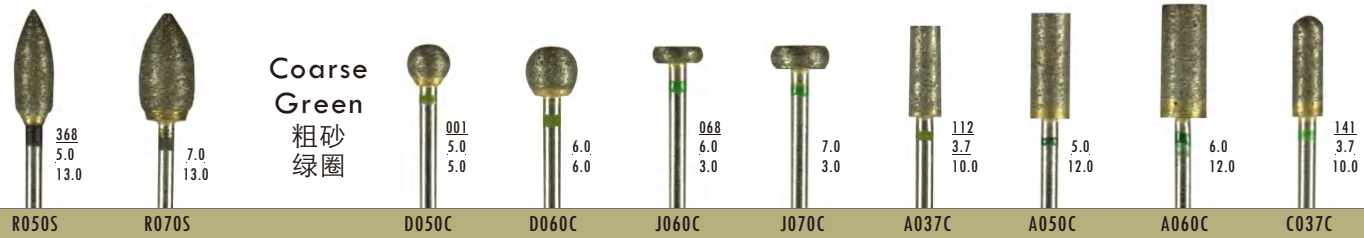

### Medium Blue 标准砂蓝圈

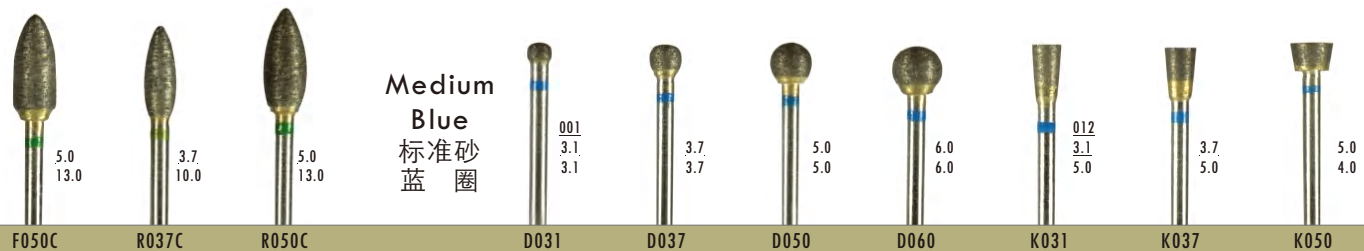

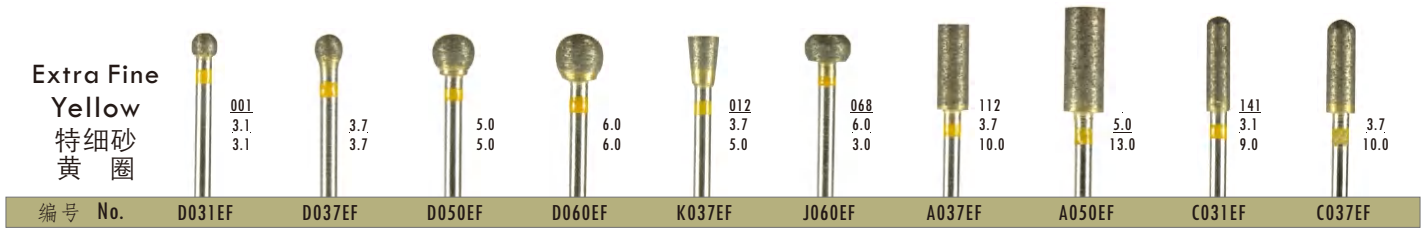
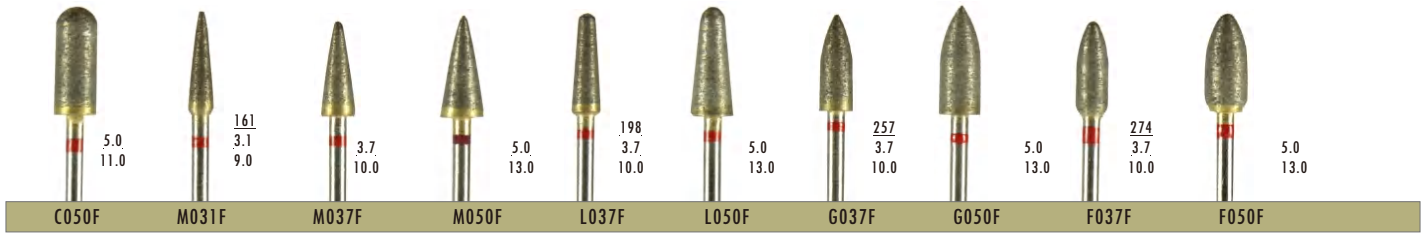
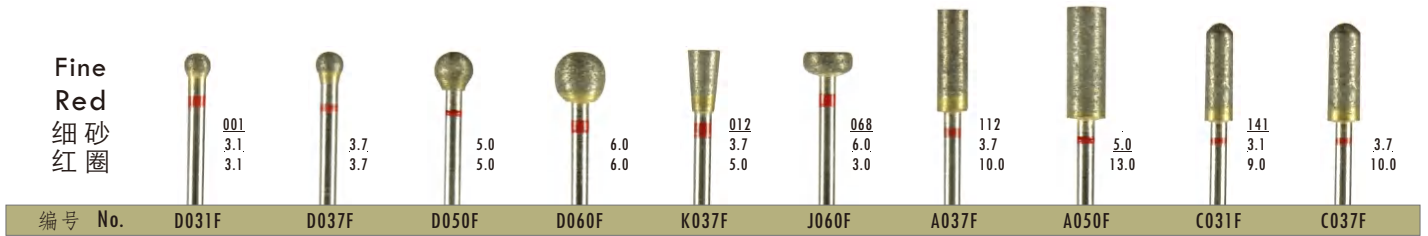
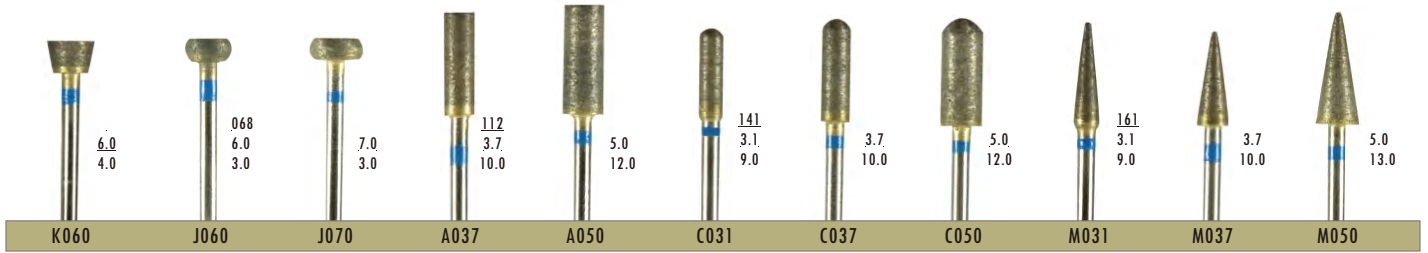

# Sintered Diamond Disc

烧结切割片

Grinding or Trimming of sintered Zirconia or any other Extra hard workpiece

用于切割烧结后的氧化锆或者各种超硬材质工件。

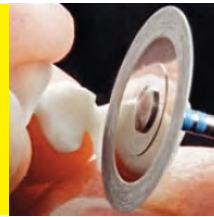

The galvanically sintered edge of the diamond discs offers excellent cutting performance.

提供三种不同粒度的砂粒，供您试用。



70 µm

Item No.



S394/190/0.25mm

19 x 0.25mm



S394/220/0.25mm

22 x 0.25mm



S394/190/0.30mm

19 x 0.30mm



S394/220/0.30mm

22 x 0.30mm



60 µm

Item No.

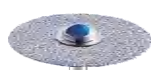

S395/190/0.25mm

19 x 0.25mm



S395/220/0.25mm

22 x 0.25mm



S395/190/0.30mm

19 x 0.30mm



S395/220/0.30mm

22 x 0.30mm



40 µm

Item No.



S396/190/0.25mm

19 x 0.25mm



S396/220/0.25mm

22 x 0.25mm



S396/190/0.30mm

19 x 0.30mm



S396/220/0.30mm

22 x 0.30mm



# Diamond Disc

金刚石切片



How to order these Discs:

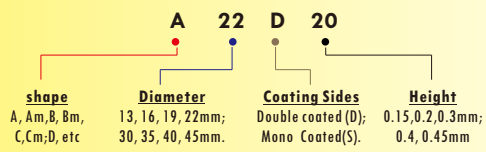

Extra Thin, 0.15mm  
Double sided  
Extra Fine  
超薄, 双面砂



编号 No.      A19D15      A22D15      Am13D15      Am16D15      Am19D15      Am22D15

Thin, 0.20 x 19mm  
Double sided  
Fine Grit  
较薄, 双面砂

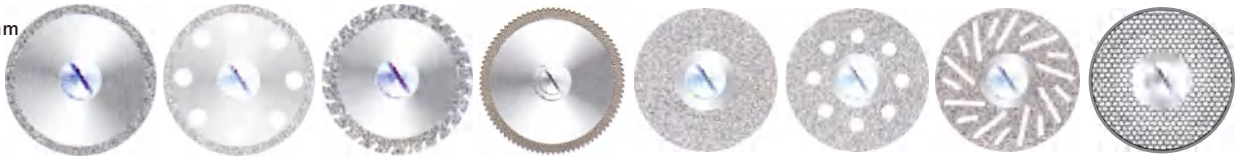

编号 No.      A19D20      B19D20      C19D20      N19D20      Am19D20      Bm19D20      Em19D20      Hm19D20

Thin, 0.20 x 22mm  
Double sided  
Fine Grit  
较薄, 双面砂



编号 No.      Am22D20      Bm22D20      Cm22D20      Em22D20      Im22D20      Jm22D20      Hm22D20



A22D20      B22D20      C22D20      E22D20      F22D20      H22D20      J22D20      N22D20

Hard, 0.3 - 0.4mm  
Double sided  
Medium Grit  
厚硬, 双面砂



编号 No.      Am19D30      Am22D30      Am22D40      A19D40      A22D40  
19.0 x 0.3 mm      22.0 x 0.3 mm      22.0 x 0.4 mm      19.0 x 0.4 mm      22.0 x 0.4 mm

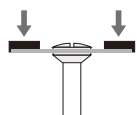

Single-sided  
仅单面镀砂



编号 No.      A22S20      Am22S20      Am22S30  
22.0 x 0.2 mm, Fine      22.0 x 0.2 mm      22.0 x 0.3 mm, Medium

Fast Cutting  
Plaster Disc ,  
0.3mm,  
Double sided  
石膏模切片  
平整、无偏摆

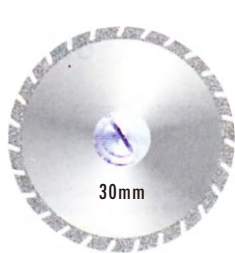

30mm



35mm

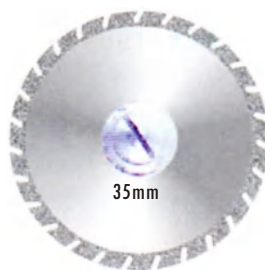

35mm

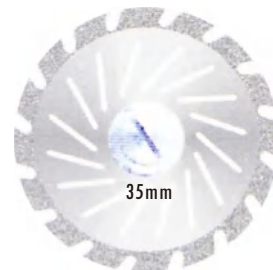

35mm

编号 No.

C30D30

A35D30

C35D30

J35D30

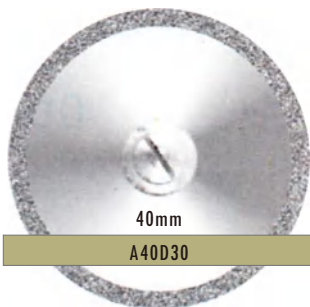

40mm

A40D30

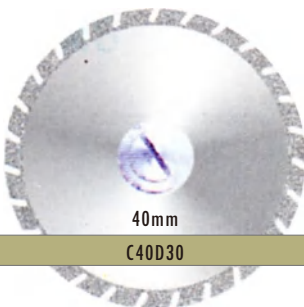

40mm

C40D30



40mm

J40D30



45mm

Cb45D30

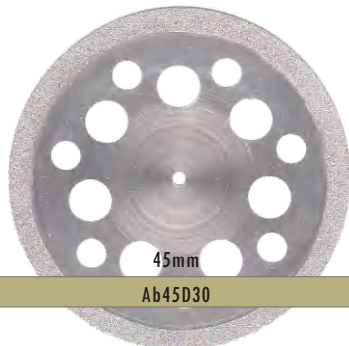

45mm

Ab45D30

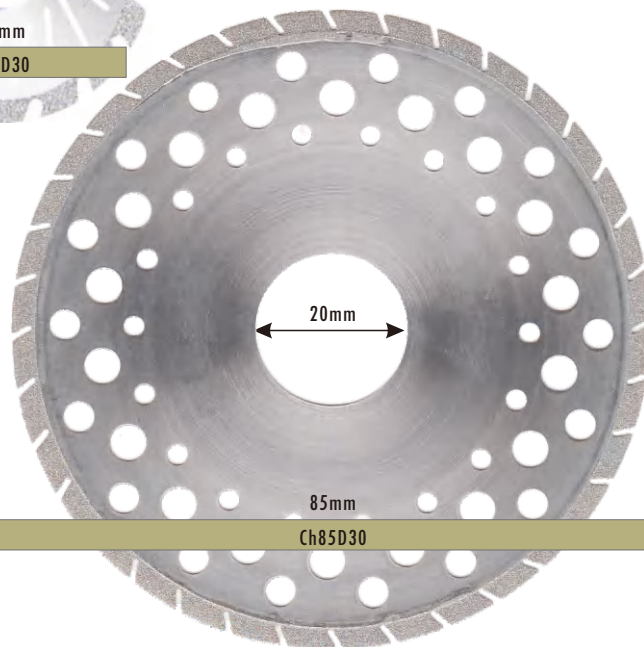

20mm

85mm

Ch85D30



Article No	Coating	D1	L1	L2	L3	D2
for Roland 00						
RL-00-06-ED	Dia.	0.6/1.5	9.0	—	40	3.0
RL-00-10-ED	Dia.	1.0	6.0	—	40	3.0
RL-00-25-ED	Dia.	2.5	15.0	—	40	3.0

Article No	Coating	D1	L1	L2	L3	D2
for Amann Girrbach 00						
AG-00-04-ED	Dia.	0.4	6.5	—	43	3.0
AG-00-10-ED	Dia.	1.0	14.0	—	43	3.0
AG-00-14-ED	Dia.	1.4	14.0	—	43	3.0
AG-00-18-ED	Dia.	1.8	14.0	—	43	3.0

Article No	Coating	D1	L1	L2	L3	D2
for VHF						
VH-00-06-ED	Dia.	0.6	6.0	—	35	3.0
VH-00-10-ED	Dia.	1.0	9.0	—	35	3.0
VH-00-25-ED	Dia.	2.5	16.0	—	35	3.0

Article No	Coating	D1	L1	L2	L3	D2
for Imes-Icore 350, 550, 750						
II-75-06-ED	Dia.	0.6	10.0	—	40	6.0
II-75-10-ED	Dia.	1.0	10.0	—	40	6.0
II-75-25-ED	Dia.	2.5	15.0	—	40	6.0

Article No	Coating	D1	L1	L2	L3	D2
for Imes-Icore 240, 250						
II-24-06-ED	Dia.	0.6	10.0	—	43	3.0
II-24-10-ED	Dia.	1.0	10.0	—	45	3.0
II-24-25-ED	Dia.	2.5	15.0	—	42	3.0

## CAD / CAM Milling Burs for Lithium Disilicate 铣刀(加工玻璃陶瓷)

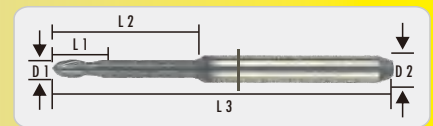

D1 : Cutting Edge Diameter (.mm) L1 : Cutting Edge Length (.mm)  
D2 : Shank Diameter (.mm) L2 : Free Grinding to (.mm)  
L3 : Total Length (.mm)

Article No	Coating	D1	L1	L2	L3	D2
for Sirona MCX5						
SR-X5-06-ED	Dia.	0.6	14.5	—	34.5	3.0
SR-X5-12-ED	Dia.	1.2	12.5	—	36.5	3.0
SR-X5-14-ED	Dia.	1.4	14.5	—	35.5	3.0
SR-X5-22-ED	Dia.	2.2	15.5	—	37.5	3.0

Article No	Coating	D1	L1	L2	L3	D2
for Sirona MCXL						
SR-XL-C125-ED	Dia.	—	13.7	—	38	3.5
Cylinder Pointed Bur 125						
SR-XL-S125-ED	Dia.	—	13.7	—	38	3.5
Step Bur 125						
SR-XL-S12-ED	Dia.	—	13.2	—	38	3.5
Step Bur 12						

Article No	Coating	D1	L1	L2	L3	D2
for Sirona MCXL						
SR-XL-CP12EF-ED	Dia.	—	19.0	—	40	3.5
Cylinder Pointed Bur 12EF						
SR-XL-C12EF-ED	Dia.	—	19.0	—	40	3.5
Cylinder Bur 12EF						

Article No	Coating	D1	L1	L2	L3	D2
for Sirona MCXL						
SR-XL-C20-ED	Dia.	—	21.5	—	46	3.5
Cylinder Pointed Bur 20						
SR-XL-S20-ED	Dia.	—	22.0	—	46.3	3.5
Step Bur 20						

Article No	Coating	D1	L1	L2	L3	D2
for Sirona Cerec 3						
SR-C3-CP-ED	Dia.	—	9.3	—	23.5	1.8
Cylinder Pointed Bur						
SR-C3-125-ED	Dia.	—	13.2	—	25.2	1.8
Step Bur 12						
SR-C3-105-ED	Dia.	—	11.5	—	23.3	1.8
Step Bur 10						

Article No	Coating	D1	L1	L2	L3	D2
for Dentium						
DT-00-06-ED	Dia.	0.6	19.8	—	50	6.0
DT-00-10-ED	Dia.	1.0	19.8	—	50	6.0
DT-00-20-ED	Dia.	2.0	19.8	—	50	6.0

Article No	Coating	D1	L1	L2	L3	D2
for Dentium						
DT-01-10-ED	Dia.	1.0	10.0	—	45	3.0
DT-01-20-ED	Dia.	2.0	12.0	—	45	3.0

Article No	Coating	D1	L1	L2	L3	D2
for Arum						
AR-00-10-ED	Dia.	1.0	10.5	—	50	6.0
AR-00-15-ED	Dia.	1.5	12.5	—	50	6.0
AR-00-20-ED	Dia.	2.0	12.5	—	50	6.0
AR-00-25-ED	Dia.	2.5	12.5	—	50	6.0

Article No	Coating	D1	L1	L2	L3	D2
for Arum 400						
AR-01-06-ED	Dia.	0.6	12.5	—	41	4.0
AR-01-10-ED	Dia.	1.0	16.0	—	44.5	4.0
AR-01-15-ED	Dia.	1.5	16.0	—	44.5	4.0
AR-01-25-ED	Dia.	2.5	16.0	—	44.5	4.0

# CAD / CAM Milling Burs.

## 铣刀

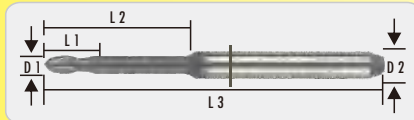

**D1** : Cutting Edge Diameter (.mm)    **L1** : Cutting Edge Length (.mm)  
**D2** : Shank Diameter (.mm)            **L2** : Free Grinding Length (.mm)  
**L3** : Total Length (.mm)

### Coating

CrN : for PMMA  
 AL : for Metal  
 NC : for Zirconia  
 DC : for Zirconia,  
 More Durable.

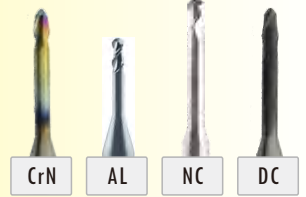

Article No	Coating	D1	L1	L2	L3	D2
for Roland 50						
RL-50-03-NC	NC	0.3	1.5	6.0	50.0	4.0
RL-50-06-CRN	CRN	0.6	1.5	6.0	50.0	4.0
RL-50-06-NC	NC					
RL-50-10A-CRN	CRN	1.0	3.5	16.0	50.0	4.0
RL-50-10A-NC	NC					
RL-50-20A-CRN	CRN	2.0	6.0	16.0	50.0	4.0
RL-50-20A-NC	NC					
RL-50-20A-DC	DC					
RL-50-10B-CRN	CRN	1.0	3.5	20.0	50.0	4.0
RL-50-10B-NC	NC					
RL-50-20B-CRN	CRN	2.0	6.0	25.0	52.0	4.0
RL-50-20B-NC	NC					
RL-50-20B-DC	DC					

Article No	Coating	D1	L1	L2	L3	D2
for 3 M ESPE LAVA						
LV-00-10-CRN	CRN	1.0	3.5	16.0	38.0	3.0
LV-00-10-NC	NC					
LV-00-20-CRN	CRN	2.0	6.0	16.0	38.0	3.0
LV-00-20-NC	NC					
LV-00-20-DC	DC					
LV-01-10-CRN	CRN	1.0	2.0	25.0	50.0	3.0
LV-01-10-NC	NC					
LV-01-20-CRN	CRN	2.0	2.0	25.0	50.0	3.0
LV-01-20-NC	NC					
LV-01-20-DC	DC					

Article No	Coating	D1	L1	L2	L3	D2
for RK						
RK-00-10-DC	DC	1.0	3.5	16.0	47.0	3.0
RK-00-20-DC	DC	2.0	3.5	16.0	47.0	3.0

Article No	Coating	D1	L1	L2	L3	D2
for Imes-Icore 240, 250						
II-24-06-CRN	CrN	0.6	1.5	10.0	48.0	3.0
II-24-06-NC	NC					
II-24-10-CRN	CrN	1.0	5.0	14.0	48.0	3.0
II-24-10-NC	NC					
II-24-25-CRN	CrN	2.5	8.0	20.0	48.0	3.0
II-24-25-NC	NC					
II-24-25-DC	DC					

Article No	Coating	D1	L1	L2	L3	D2
for Imes-Icore 350, 550, 750						
II-75-06-CRN	CrN	0.6	2.5	12.0	53.0	6.0
II-75-06-NC	NC					
II-75-10-CRN	CrN	1.0	6.0	14.0	53.0	6.0
II-75-10-NC	NC					
II-75-25-CRN	CrN	2.5	10.0	20.0	53.0	6.0
II-75-25-NC	NC					
II-75-25-DC	DC					



Article No	Coating	D1	L1	L2	L3	D2
for Amann Girrbach						
AG-00-06-CRN	CrN	0.6	1.5	13.0	47.0	3.0
AG-00-06-NC	NC					
AG-00-10-CRN	CrN	1.0	3.5	16.0	47.0	3.0
AG-00-10-NC	NC					
AG-00-25-CRN	CrN	2.5	5.0	16.0	47.0	3.0
AG-00-25-NC	NC					
AG-00-25-DC	DC					



Article No	Coating	D1	L1	L2	L3	D2
for Amann Girrbach - Metal mill						
AG-01-10-AL	Alnova	1.0	5.0	7.0	43.0	3.0
AG-01-20-AL	Alnova	2.0	5.0	7.0	43.0	3.0



Article No	Coating	D1	L1	L2	L3	D2
for VHF K1, K4						
VH-K4-06-CRN	CRN	0.6	2.0	7.0	35.0	3.0
VH-K4-06-NC	NC					
VH-K4-10-CRN	CRN	1.0	3.5	16.0	35.0	3.0
VH-K4-10-NC	NC					
VH-K4-20-CRN	CRN	2.0	5.0	16.0	35.0	3.0
VH-K4-20-NC	NC					



Article No	Coating	D1	L1	L2	L3	D2
for VHF K5						
VH-K5-03-NC	CRN	0.3	1.2	13.0	40.0	3.0
VH-K5-06-CRN	CRN	0.6	1.5	7.0	40.0	3.0
VH-K5-06-NC	NC					
VH-K5-10-CRN	CRN	1.0	3.5	14.0	40.0	3.0
VH-K5-10-NC	NC					
VH-K5-20-CRN	CRN	2.0	4.5	16.0	40.0	3.0
VH-K5-20-NC	NC					
VH-K5-20-DC	DC					



Article No	Coating	D1	L1	L2	L3	D2
for Dentium						
DT-00-10-NC	NC	1.0	3.5	16.0	50.0	6.0
DT-00-20-NC	NC	2.0	3.5	16.0	50.0	6.0
DT-00-20-DC	DC					
DT-01-05-NC	NC	0.5	2.0	8.0	43.0	3.0
DT-01-10-CrN	CrN	1.0	3.5	16.0	50.0	3.0
DT-01-10-NC	NC					
DT-01-20-CrN	CrN	2.0	3.5	18.0	50.0	3.0
DT-01-20-NC	NC					
DT-01-20-DC	DC					

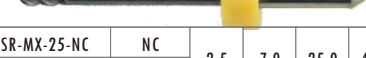

Article No	Coating	D1	L1	L2	L3	D2
for Zirkon Zahn M3						
						
ZZ-03-05-CRN	CrN	0.5	1.5	6.0	57.0	3.0
ZZ-03-05-NC	NC					
						
ZZ-03-10-CRN	CrN	1.0	6.0	12.0	57.0	3.0
ZZ-03-10-NC	NC					
						
ZZ-03-20-CRN	CrN	2.0	10.0	18.0	57.0	3.0
ZZ-03-20-NC	NC					
ZZ-03-20-DC	DC					

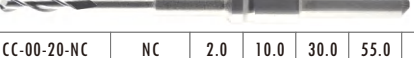

Article No	Coating	D1	L1	L2	L3	D2
for Zirkon Zahn M5, M6, etc						
						
ZZ-06-05-NC	NC	0.5	1.5	3.0	50.0	6.0
						
ZZ-06-10-NC	NC	1.0	6.0	12.0	50.0	6.0
						
ZZ-06-20-NC	NC	2.0	10.0	18.0	50.0	6.0
ZZ-06-20-DC	DC					



Article No	Coating	D1	L1	L2	L3	D2
for Sirona MX 5						
						
SR-MX-05-NC	NC	0.5	1.5	5.0	42.0	3.0
						
SR-MX-10-NC	NC	1.0	4.5	18.0	43.0	3.0
						
SR-MX-25-NC	NC	2.5	7.0	25.0	43.0	3.0
SR-MX-25-DC	DC					

Article No	Coating	D1	L1	L2	L3	D2
for Cercon						
						
CC-00-05-NC	NC	0.5	2.0	10.0	55.0	3.5
						
CC-00-10-NC	NC	1.0	8.0	30.0	55.0	3.5
						
CC-00-20-NC	NC	2.0	10.0	30.0	55.0	3.5



Article No	Coating	D1	L1	L2	L3	D2
for Arum						
						
AR-00-10-CrN	CrN	1.0	2.0	16.0	55.0	6.0
AR-00-10-NC	NC					
						
AR-00-20-CrN	CrN	2.0	6.0	20.0	55.0	6.0
AR-00-20-NC	NC					
AR-00-20-DC	DC					

Article No	Coating	D1	L1	L2	L3	D2
for Wieland Mini						
						
WL-MI-07-CRN	CrN	0.7	1.5	7.0	35.0	3.0
WL-MI-07-NC	NC					
						
WL-MI-10-CRN	CrN	1.0	3.5	16.0	35.0	3.0
WL-MI-10-NC	NC					
						
WL-MI-25-CRN	CrN	2.5	3.5	20.0	35.0	3.0
WL-MI-25-NC	NC					

Article No	Coating	D1	L1	L2	L3	D2
for Wieland S1						
						
WL-S1-07-CRN	CrN	0.7	1.5	7.0	40.0	3.0
WL-S1-07-NC	NC					
						
WL-S1-10-CRN	CrN	1.0	3.5	16.0	40.0	3.0
WL-S1-10-NC	NC					
						
WL-S1-25-CRN	CrN	2.5	5.0	20.0	40.0	3.0
WL-S1-25-NC	NC					
WL-S1-25-DC	DC					

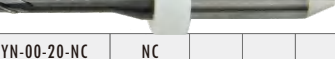
Article No	Coating	D1	L1	L2	L3	D2
for Kavo						
						
KA-00-10-DC	DC	1.0	2.0	16.0	53.0	6.0
						
KA-00-20-DC	DC	2.0	6.0	19.5	53.0	6.0

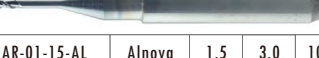
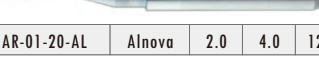
Article No	Coating	D1	L1	L2	L3	D2
for Yena						
						
YN-00-10-NC	NC	1.0	3.5	16.0	45.0	4.0
						
YN-00-20-NC	NC	2.0	3.5	16.0	45.0	4.0
YN-00-20-DC	DC					

Article No	Coating	D1	L1	L2	L3	D2
for Arum - Metal Mill						
						
AR-01-10-AL	Alnova	1.0	2.0	10.0	50.0	6.0
						
AR-01-15-AL	Alnova	1.5	3.0	10.0	50.0	6.0
						
AR-01-20-AL	Alnova	2.0	4.0	12.0	50.0	6.0
						
AR-01-30-AL	Alnova	3.0	6.0	12.0	50.0	6.0

# Tungsten Carbide Burs . HP

## 钨钢车针



### Shape

- S1, ISO 001, Round
- S2, ISO 002, Inverted cone
- S21, S31, ISO 107, Cylinder
- S33, ISO 168, Taper
- S31R, ISO 137, Round, Cylinder

球型/Round	S1									
编号 No.	1005	1006	1007	1008	1009	1010	1012	1014	1016	1018
参考号 Ref.	HP1/4	HP1/2	HP1s	HP 1	HP 1b	HP 2	HP 3	HP 4	HP 5	HP 6

倒锥/Inv. Cone					S2					
编号 No.	1021	1023	1025	1027	1031	2008	2010	2012	2014	2016
参考号 Ref.	HP 7	HP 8	HP 9	HP 10	HP 12	HP 34	HP 35	HP 36	HP 37	HP 38

圆柱/Cylinder			S21							
编号 No.	2018	2021	2023	21008	21009	21010	21012	21014	21016	21018
参考号 Ref.	HP 39	HP 40	HP 41	HP 55	HP 56	HP 57	HP 58	HP 59	HP 60	HP 61

圆柱/Cylinder										
编号 No.	21021	21023	31008	31009	31010	31012	31014	31016	31018	31021
参考号 Ref.	HP 62	HP 63	HP 555	HP 556	HP 557	HP 558	HP 559	HP 560	HP 561	HP 562

平锥/Taper							平锥加长/Taper L		
编号 No.	31023	33008	33009	33010	33012	33016	33021	33023	33L009
参考号 Ref.	HP 563	HP 698	HP 699	HP 700	HP 701	HP 702	HP 703	HP 704	HP 699 L

圆头柱 Round Cyl.				S31R			
编号 No.	33L010	33L012	33L016	33L021	31R010	31R012	31R014
参考号 Ref.	HP 700 L	HP 701 L	HP 702 L	HP 703 L	HP 1557	HP 1558	HP 1559

# Tungsten Carbide Cutter . HP 钨钢磨头

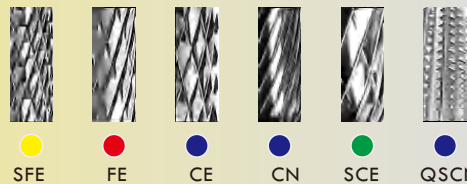
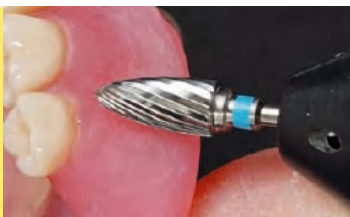

Super Fine  
Cross Cut  
(SFE)  
特细双纹  
黄圈  
ISO 500.104.110.



编号 No.	C023SFE	F040SFE	F060SFE	G023SFE	L016SFE	L023SFE	L040SFE	L060SFE	M060SFE	P023SFE
参考号 Ref.	0230.023	7230.040	5430.060	1030.023	1230.016	0130.023	5730.040	5530.060	5930.060	7730.023

Fine  
Cross Cut  
(FE)  
较细双纹  
红圈  
ISO 500.104.140.



编号 No.	Q023SFE	Q023SFE	C023FE	C060FE	F060FE	G040FE	G060FE	L016FE	L023FE
参考号 Ref.	0830.023	0430.023	0220.023	5820.060	5420.060	6120.040	5320.060	1220.016	0120.023

Medium  
Cross Cut  
(CE)  
标准双纹  
蓝圈  
ISO 500.104.190.



编号 No.	L040FE	L060FE	M060FE	P023FE	P060FE	Q023FE	A023CE	C023CE	C060CE
参考号 Ref.	5720.040	5520.060	5920.060	7720.023	5120.060	0420.023	0310.023	0210.023	5810.060



编号 No.	D023CE	D030CE	D040CE	D050CE	F040CE	F060CE	G023CE	G040CE	G060CE	L023CE
参考号 Ref.	7110.023	7110.030	7110.040	7110.050	7210.040	5410.060	1010.023	6110.040	5310.060	0110.023



								
201 040 14.0	201 060 15.0	167 023 14.50	167 040 14.5	161 060 15.0	237 023 5.0	237 060 11.0	292 023 16.0	001 030 3.0
<b>L040CE</b>	<b>L060CE</b>	<b>M023CE</b>	<b>M040CE</b>	<b>M060CE</b>	<b>P023CE</b>	<b>P060CE</b>	<b>Q023CE</b>	<b>D030CN</b>
5710.040	5510.060	—	—	5910.060	7710.023	5110.060	0410.023	7170.030

Medium Plain Cut (CN)  
标准单纹  
蓝圈  
ISO 500.104.175.

									
001 040 4.0	001 050 5.0	201 040 14.0	201 060 15.0	161 060 14.0	257 060 12.0	274 060 14.0	201 060 14.0	274 060 14.0	257 060 12.0
<b>D040CN</b>	<b>D050CN</b>	<b>L040CN</b>	<b>L060CN</b>	<b>M060CN</b>	<b>G060CN</b>	<b>F060CN</b>	<b>C060SCE</b>	<b>F060SCE</b>	<b>G060SCE</b>
7170.040	7170.050	5770.040	5570.060	5970.060	5370.060	5470.060	5850.060	5450.060	5350.060

Coarse Cross Cut (SCE)  
粗糙双纹  
绿圈  
ISO 500.104.220

							
201 040 14.0	201 060 14.0	237 060 11.0	263 070 14.0	274 060 15.0	201 023 14.5	200 045 13.0	263 060 12.0
<b>L040SCE</b>	<b>L060SCE</b>	<b>P060SCE</b>	<b>L070XCE</b>	<b>F060QSCN</b>	<b>L023QSCN</b>	<b>L045QSCN</b>	<b>LB060QSCN</b>
5750.040	5550.060	5150.060	6055.070	7275.060	0175.023	5675.045	5275.060

Super Coarse Cross Cut (XCE)  
特粗双纹  
黑圈  
ISO 500.104.223

Straight Edge with Spiral Cut (QSCN)  
直刃螺旋纹  
蓝圈  
ISO 500.104.176

							
141 023 8.0	194 023 8.0	201 040 14.0	289 023 8.0	274 040 11.5	274 060 15.0	201 023 14.5	201 040 13.0
<b>CS023GTi</b>	<b>LS023GTi</b>	<b>L040GTi</b>	<b>QS023GTi</b>	<b>F040QF</b>	<b>F060QF</b>	<b>L023QF</b>	<b>L040QF</b>
1726.023	0726.023	5726.040	0826.023	7224.040	5424.060	0124.023	5724.040

Straight Edge with Cross Cut (GTi)  
直刃双纹  
黑圈  
ISO 500.104.194

Spiral Cut Fine (QF)  
较细螺旋纹  
红圈  
ISO 500.104.134

						
141 023 8.0	274 060 14.0	198 023 8.0	201 040 14.0	289 023 8.0	118 060 3.5	467 023 9.0
<b>CS023QSF</b>	<b>F060QSF</b>	<b>LS023QSF</b>	<b>L040QSF</b>	<b>QS023QSF</b>	<b>ES801</b>	<b>AL023S4</b>
1725.023	5425.060	0725.023	5725.040	0825.023	118.060	467.023

Spiral Cut Extra Fine (QSF)  
特细螺旋纹  
黄圈  
ISO 500.104.137

# Tungsten Carbide Burs for Milling Machines

钨钢车针(精密研磨仪用)



Precisely match Various System  
 Extra - long working life & high cutting capacity ;  
 Used for trimming, polishing implant teeth shoulders ;  
 Milling precious or Non-precious metals or Titanium .

Medium  
 Cross Cut  
 (CM, LM)  
 标准双纹  
 ISO 500.103.190

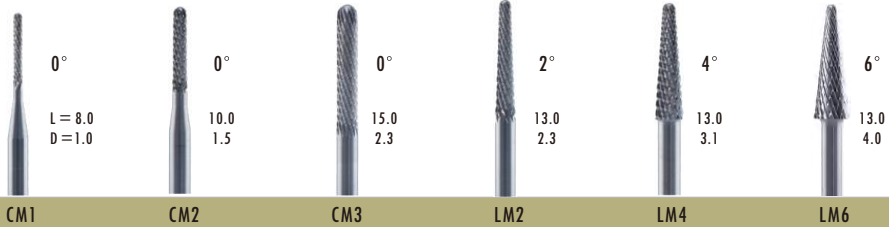

Fine  
 Cross Cut  
 (CF, LF)  
 较细单纹  
 ISO 500.103.135

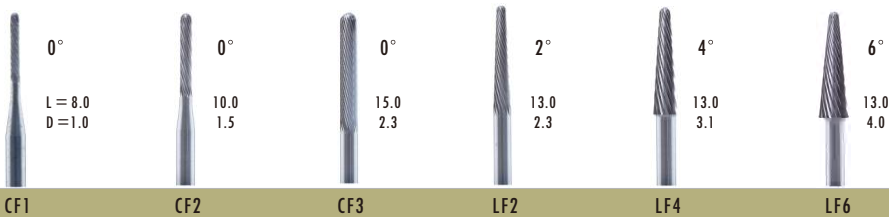

Coarse  
 Cross Cut  
 (CC, LC)  
 粗糙双纹  
 ISO 500.103.220



Max Mill  
 (CW, LW)  
 蜡型针  
 ISO 500.103.217

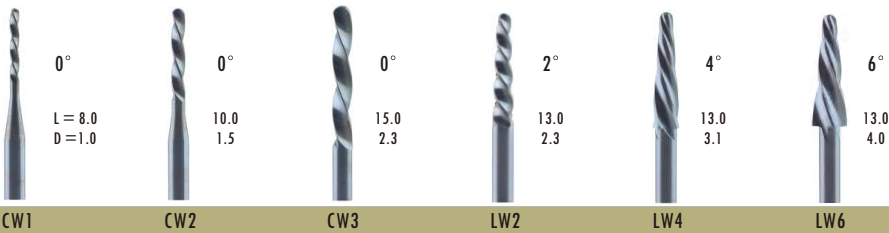

# DuCoBur<sup>®</sup> 陶瓷结合剂金刚石磨头 (全瓷、全锆磨头)

Diamond Stones for Zirconia or AllCeramics (Ceramic Pregnant Diamond Grinding Burs)



Widely Used for Zirconia, Lithium Disilicate, Ceramics etc.  
COMFORTABLE at the minimal pressure;  
HEATLESS no need water cooling;  
MORE DURABLE under our suggested PRM

不产热、无需水冷 更耐磨、经济实惠 更锋利、手感好 不绷瓷、更轻松 型号齐、用途广、啥都磨得动

Medium Blue  
蓝色、中等粒度



Item No.



DC009 DC010 DC010B DC011 DC014 DC015 DC016 DC017 DC003A

Size (mm) 4 x 4 4 x 7 4 x 11 3 x 7 2.5 x 4.5 3.5 x 10 2.5 x 7 3.5 x 11 6.5 x 2



DC001 DC002 DC002B DC012 DC012B DC013 DC004A

4 x 13 5 x 13 6.5 x 13 13 x 2 13 x 3.5 13 x 2 16 x 2/0.7



DC005A DC004 DC005 DC006 DC007

16 x 2 22 x 2/0.7 22 x 2 22 x 4.5 15 x 3.5

Medium Black  
黑色、中等粒度



Item No.



DX001 DX002 DX002B DX012 DX012B DX013 DX004A

Size (mm) 4 x 13 5 x 13 6.5 x 13 13 x 2 13 x 3.5 13 x 2 16 x 2/0.7



DX005A DX004 DX005 DX006 DX007

16 x 2 22 x 2/0.7 22 x 2 22 x 4.5 15 x 3.5



Medium Yellow

黄色、中等粒度

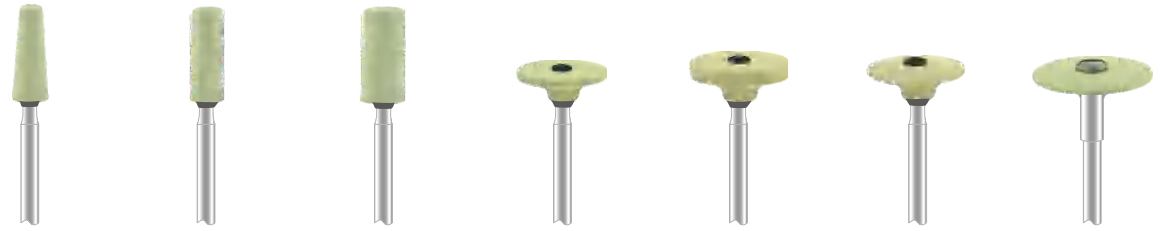

Item No.	DY001	DY002	DY002B	DY012	DY012B	DY013	DY004A
Size (mm)	4 x 13	5 x 13	6.5 x 13	13 x 2	13 x 3.5	13 x 2	16 x 2/0.7



Item No.	DY005A	DY004	DY005	DY006	DY007
Size (mm)	16 x 2	22 x 2/0.7	22 x 2	22 x 4.5	15 x 3.5

Medium Green

绿色、中等粒度



Item No.	DG009	DG010	DG010B	DG011	DG014	DG015	DG016	DG017	DG003A
Size (mm)	4 x 4	4 x 7	4 x 11	3 x 7	2.5 x 4.5	3.5 x 10	2.5 x 7	3.5 x 11	6.5 x 2



Item No.	DG001	DG002	DG002B	DG012	DG012B	DG013	DG004A
Size (mm)	4 x 13	5 x 13	6.5 x 13	13 x 2	13 x 3.5	13 x 2	16 x 2/0.7

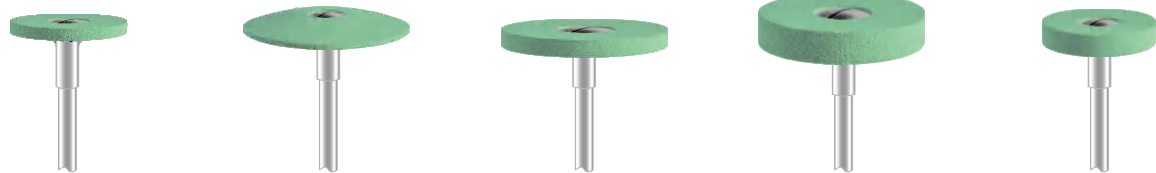

Item No.	DG005A	DG004	DG005	DG006	DG007
Size (mm)	16 x 2	22 x 2/0.7	22 x 2	22 x 4.5	15 x 3.5

 Extra Fine  
 Yellow  
 Gold shank

Suitable to adjusting Lithium Disilicate, All Ceramics, Zirconia of Occlusal, Lingual, Edge, Intracoronal, Proximal etc. Dentists will feel very convenient if they can prepare a few pieces beside the chairs.

专门针对诊所的全瓷、玻璃陶瓷打磨抛光、氧化锆牙调咬合、发育沟、窝沟、边缘、内冠、邻面、舌侧等。黄色、特细粒度。粒度细、不绷瓷。

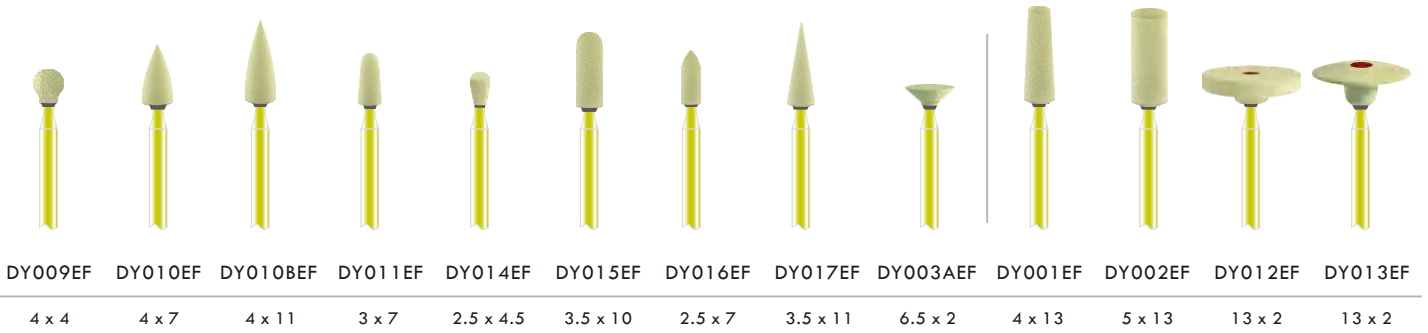





**DuCoBur** <sup>®</sup> 橡胶结合剂金刚石磨头  
 豆酷巴 (全瓷、全锆抛光磨头)

Diamond Polishers for Zirconia or AllCeramics  
( Rubber Pregnant Diamond Polishing Burs )



Widely Used for Zirconia, Lithium Disilicate, Ceramics etc.

COMFORTABLE at the minimal pressure;  
HEATLESS no need water cooling ;  
MORE DURABLE under our suggested PRM

不产热、无需水冷  更耐磨、经济实惠  手感好、很服帖  抛就亮、更轻松  型号齐、用途广、啥都抛得亮

 Super Coarse  
 Black  
 黑色、特粗粒度

 1

Item No.

D1S

D2AS

D2S

D3S

D3BS

Size (mm)

26 x 2

20 x 2

26 x 2

22 x 3

26 x 2

 Coarse  
 Green  
 绿色、粗糙粒度

 1

Item No.

D1C

D2AC

D2C

D3C

D3BC

Size (mm)

26 x 2

20 x 2

26 x 2

22 x 3

26 x 2

Medium Blue  
蓝色、中等粒度



Item No.	D1M	D2AM	D2M	D3M	D3BM
Size (mm)	26 x 2	20 x 2	26 x 2	22 x 3	26 x 2



D201M	D203M	D205M	D205BM	D207M	D13M	D17M	D26M
5 x 16	6 x 16	12 x 2	12 x 4	12 x 2.5	14 x 2	17 x 2.2	26 x 2.2

Fine Red  
红色、较细粒度



Item No.	D1F	D2AF	D2F	D3F	D3BF
Size (mm)	26 x 2	20 x 2	26 x 2	22 x 3	26 x 2



D201F	D203F	D205F	D205BF	D207F	D13F	D17F	D26F
5 x 16	6 x 16	12 x 2	12 x 4	12 x 2.5	14 x 2	17 x 2.2	26 x 2.2

Extra Fine  
Yellow  
黄色、特细粒度



Item No.	D1EF	D2AEF	D2EF	D3EF	D3BEF
----------	------	-------	------	------	-------

Size (mm)	26 x 2	20 x 2	26 x 2	22 x 3	26 x 2
-----------	--------	--------	--------	--------	--------

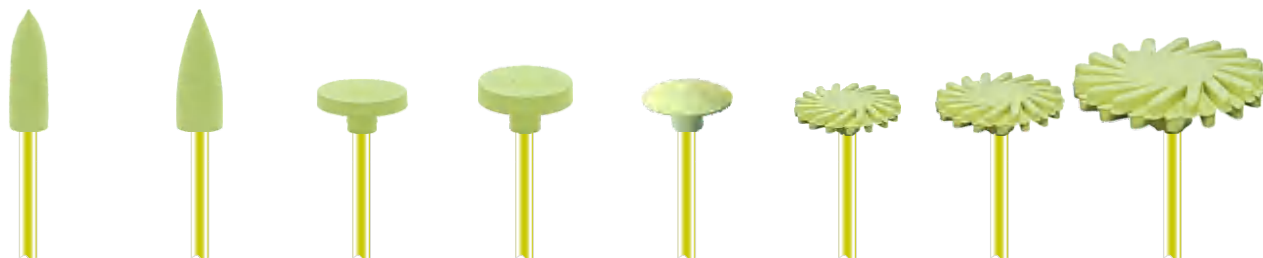

D201EF	D203EF	D205EF	D205BEF	D207EF	D13EF	D17EF	D26EF
--------	--------	--------	---------	--------	-------	-------	-------

5 x 16	6 x 16	12 x 2	12 x 4	12 x 2.5	14 x 2	17 x 2.2	26 x 2.2
--------	--------	--------	--------	----------	--------	----------	----------

Ultra Fine  
Grey  
灰白色、特细粒度



Item No.	D1UF	D2AUF	D2UF	D3UF	D3BUF
----------	------	-------	------	------	-------

Size (mm)	26 x 2	20 x 2	26 x 2	22 x 3	26 x 2
-----------	--------	--------	--------	--------	--------

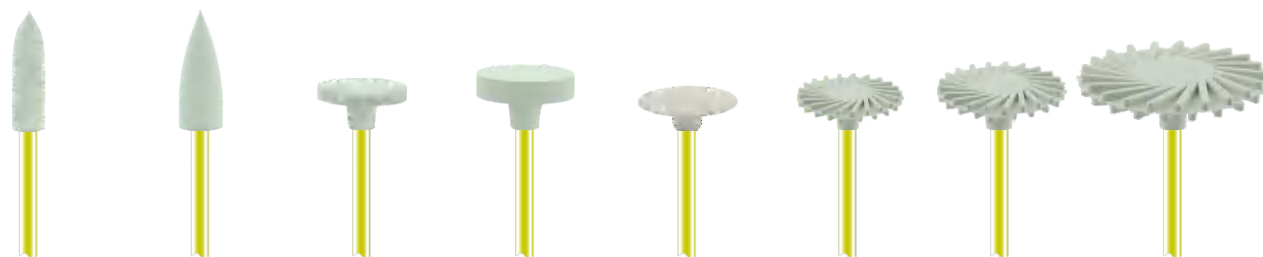

D201UF	D203UF	D205UF	D205BUF	D207UF	D13UF	D17UF	D26UF
--------	--------	--------	---------	--------	-------	-------	-------

5 x 16	6 x 16	12 x 2	12 x 4	12 x 2.5	14 x 2	17 x 2.2	26 x 2.2
--------	--------	--------	--------	----------	--------	----------	----------

**Silicon Rubber Wheels ,  
Points & Burs  
For Polish Ceramics  
胶轮、胶粒、硅胶磨头  
(烤瓷牙抛光)**

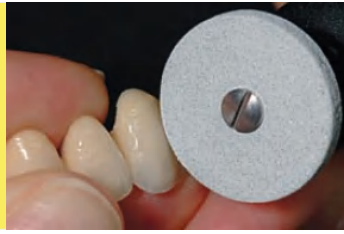

White, Coarse , to adjust and remove Porcelain  
白色, 粗糙, 用于烤瓷工件的修整。  
Pink, Medium , to Smooth or polish Porcelain,  
粉色, 中等, 用于烤瓷毛面平整和预抛光。  
Blue, Fine , to high-lustre polishing Porcelain,  
蓝色, 较细, 用于烤瓷工件的细抛光。

Coarse  
White  
白色、粗糙



100

Item No.



C 104 C



C 107 C



C 101 C



C203C



C201C



C205C



C207C

Size (mm)

22x 3

22 x 3

6 x 22

6 x 13

5 x 13

12 x 2

13 x 2

Medium  
Pink  
粉色、中等粒度



100

Item No.



C 104 M



C 107 M



C 101 M



C203M



C201M



C205M



C207M

Size (mm)

22x 3

22 x 3

6 x 22

6 x 13

5 x 13

12 x 2

13 x 2

Fine  
Blue  
蓝色、较细



100

Item No.



C 104 F



C 107 F



C 101 F



C203F



C201F



C205F



C207F

Size (mm)

22x 3

22 x 3

6 x 22

6 x 13

5 x 13

12 x 2

13 x 2

**Rubber Wheels , Points & Burs  
For Polish Metal or Alloy  
胶轮、胶粒、橡胶磨头  
(金属、合金抛光)**



Black, Coarse , to adjust Cobalt-Chromium  
Alloy and hard metal  
黑色, 粗糙, 用于磨削钴铬合金和硬金属。  
Brown, Medium , to remove metal and  
semi-precious metal  
棕色, 中等, 用于烤瓷毛面平整和预抛光。  
Green, Fine , to fast smooth scratch or polish metal,  
绿色, 较细, 用于快速去除划痕和抛光金属。

Coarse  
Black  
黑色、较粗



100

Item No.



A102 C



A103C



A104 C



A203C



A201C



A206C



A207C

Size (mm)

22x 3

22 x 3

6 x 22

4 x 12

5 x 13

12 x 2

13 x 2

Medium Brown  
棕色、中等粒度  
100



Item No.	A102 M	A103 M	A104 M	A203M	A201M	A206M	A207M
Size (mm)	22x 3	22 x 3	6 x 22	4 x 12	5 x 13	12 x 2	13 x 2

Fine Green  
绿色、较细  
100



Item No.	A102 F	A103 F	A104 F	A203F	A201F	A206F	A207F
Size (mm)	22x 3	22 x 3	6 x 22	4 x 12	5 x 13	12 x 2	13 x 2

Silicon Polishing Burs  
For Composites, Resins  
硅胶磨头  
(树脂胶托抛光)



Green, Coarse, to reduce, finish Acrylic, Resin.  
绿色, 粗糙, 用于修整和成型树脂胶托。  
Gray, Medium, to Smooth Acrylic, Resin.  
灰黑色, 中等, 用于平整和预抛光树脂胶托。  
Yellow, Fine, to final polish Acrylic, Resin.  
黄色, 较细, 用于树脂胶托的细抛光。

Coarse Green  
绿色、粗糙  
100



Item No.	Rh 101 C	Rh 103 C	Rh 106 C	R103C	R106C	R209C
Size (mm)	13 x 20	10x 24	10 x 20	10x 24	10 x 20	6 x 13

Medium Gray  
灰黑、中等粒度  
100



Item No.	Rh 101 M	Rh 103 M	Rh 106 M	R103M	R106M	R209M
Size (mm)	13 x 20	10x 24	10 x 20	10x 24	10 x 20	6 x 13

Fine Yellow  
黄色、较细  
100



Item No.	Rh 101 F	Rh 103 F	Rh 106 F	R103F	R106F	R209F	R202F
Size (mm)	13 x 20	10x 24	10 x 20	10x 24	10 x 20	6 x 13	4 x 12

Green Stones  
Contour Ceramic

绿车石  
调烤瓷

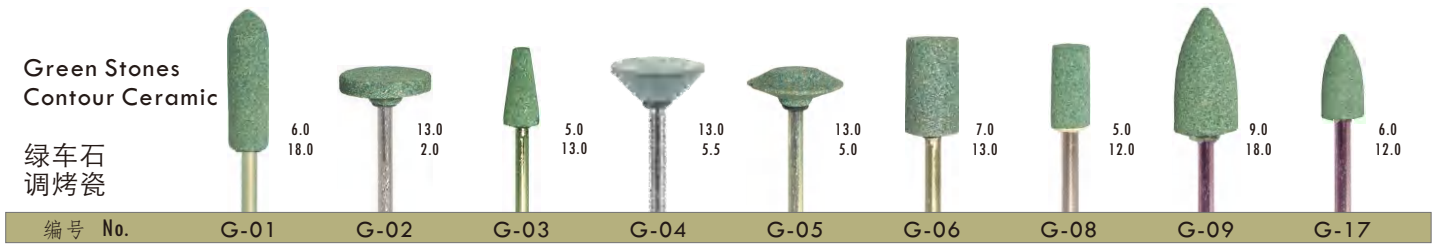

Pink Stones  
for Metal  
粉车石  
调金属,合金



White Stone  
for Metal  
Composite,  
白车石  
调金属,树脂

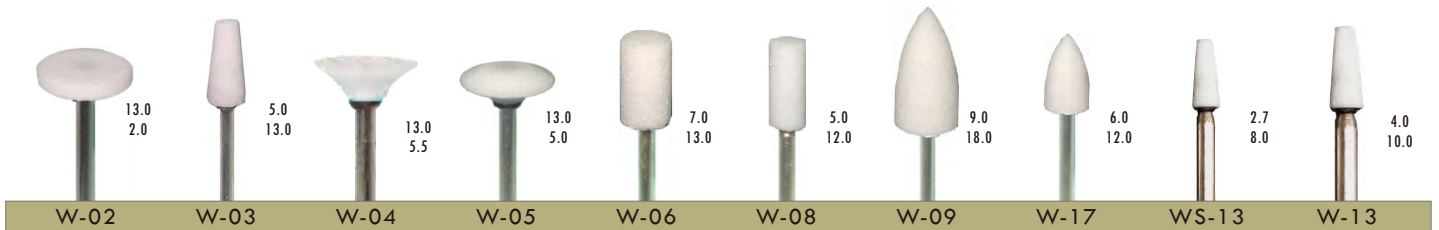
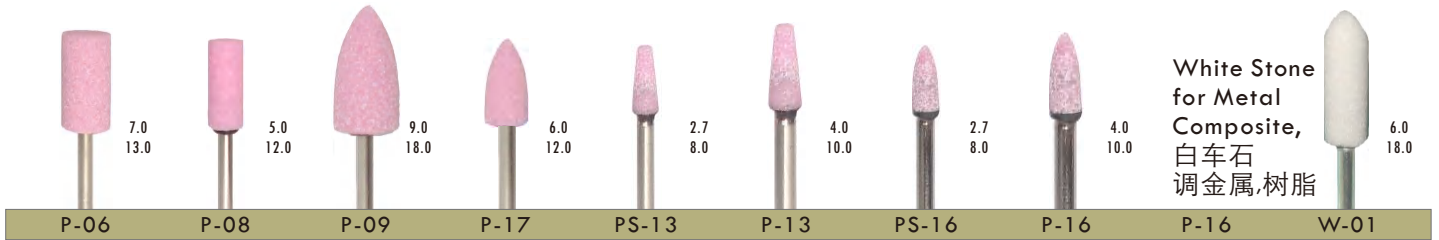

Mounted Sandpaper 砂纸棒

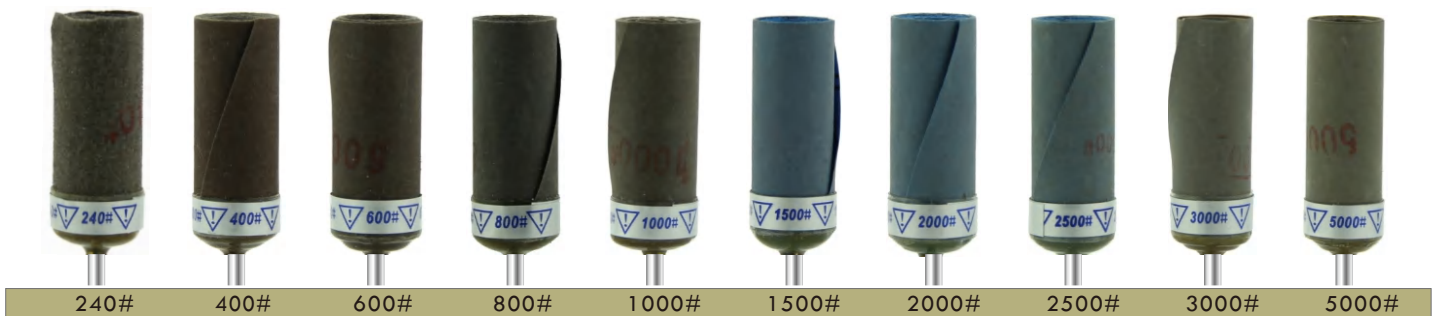



# Polishing Brushes 抛光刷

							
百洁布 暗红,中粗	百洁布 红,硬	百洁布 棕,中粗	百洁布 紫,软	百洁布 普通			
<b>01MT25</b> Red.Soft	<b>01Mp25</b> Red.coarse	<b>01My25</b> Brown.Medium	<b>01Ms25</b> Purple.fine	<b>01M22</b> Blue			
							
碳化硅 磨料丝	氧化铝 磨料丝	曲钢丝	曲铜丝	黑猪鬃	灰马毛	灰羊毛	
<b>01SiC22</b> Silicon Carbide	<b>01Al22</b> Al. Oxide	<b>01A22</b> Crimped steel wire	<b>01B22</b> Crimped brass wire	<b>01D22</b> Chungking Bristle	<b>01E22</b> Grey Pony hair	<b>01F22</b> Grey goat hair	
							
白羊毛	灰羊毛 +超纤皮	黑猪鬃 19mm	灰马毛	灰羊毛	白羊毛		
<b>01G22</b> White goat hair	<b>01Fr22</b> Goat hair / chamois	<b>01D19</b> Chungking Bristle	<b>01E19</b> Grey Pony hair	<b>01F19</b> Grey goat hair	<b>01G19</b> White goat hair		
							
黄棉布	白棉布	橘红 羊皮	双面绒 羊皮	咖啡 超纤	白厚 超纤	羊绒	白棉线
<b>01P22</b> Yellow cloth	<b>01Q22</b> White cloth	<b>01R22</b> Chamois leather	<b>01Ry22</b> Sheep Leather	<b>01R22.2</b> Brown Micro-Fiber	<b>01Ry22.2</b> White Microfiber	<b>01S22</b> Cashmere	<b>01T22</b> Cotton yarn
							
黑猪鬃	灰马毛	白羊毛	曲钢丝	曲铜丝	黑猪鬃	灰羊毛	
<b>02D22</b> Chungking Bristle	<b>02E22</b> Pony hair	<b>02G22</b> White goat hair	<b>04A12</b> Steel	<b>04B12</b> Brass	<b>04D12</b> Bristle	<b>04F12</b> Goat Hair	
							
碳化硅 磨料丝	氧化铝 磨料丝	曲钢丝	曲铜丝	黑猪鬃	灰马毛	灰羊毛	
<b>05SiC05</b> SiC	<b>05Al05</b> Al. Oxide	<b>05A05</b> Steel	<b>05B05</b> Brass	<b>05D05</b> Bristle	<b>05E05</b> Pony Hair	<b>05F05</b> Goat Hair	



Polishing brush & Wheel  
in Bristle, Cotton Cloth  
抛光刷



These brushes are made of bristle hair or White, yellow pure cotton cloth, assembled on polishing latch to finish or polish Plaster Moulds, Acrylic 台式抛光机配用的抛光刷/布轮,用于抛光塑料,树脂,模型等。

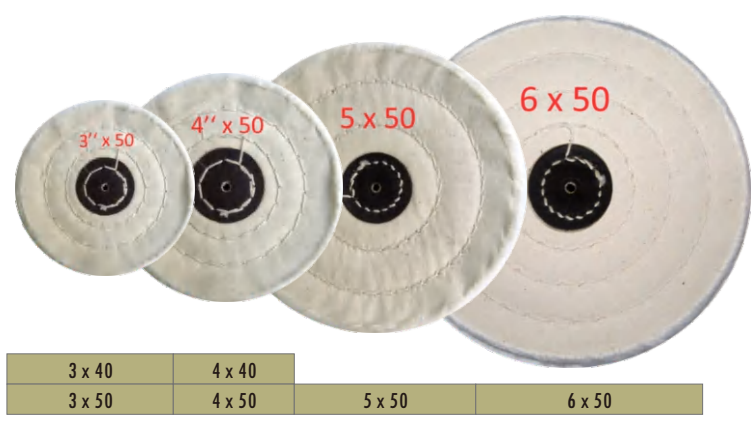
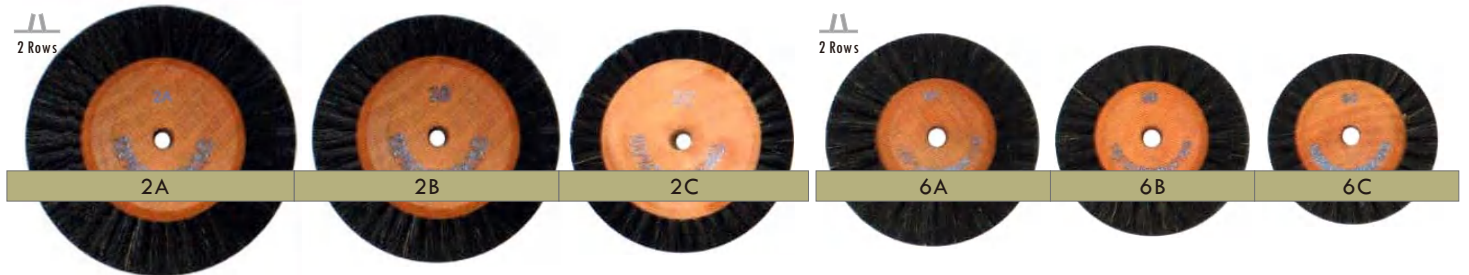
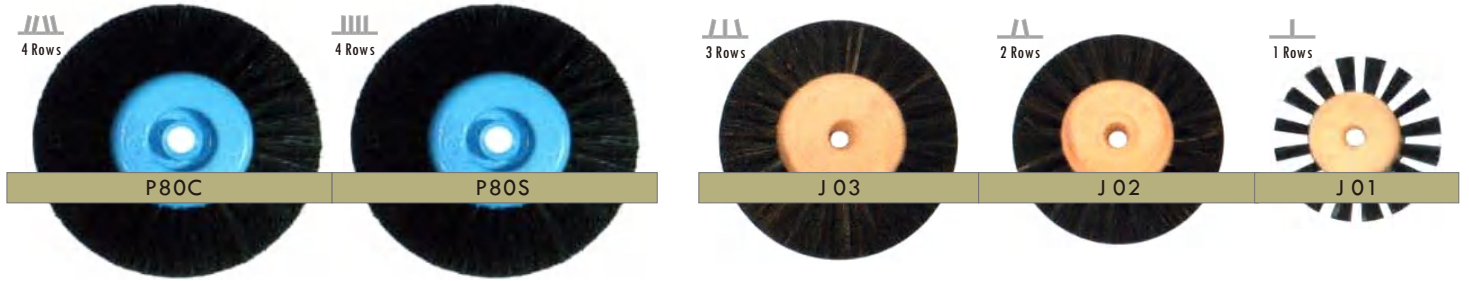

3 x 40	4 x 40		
3 x 50	4 x 50	5 x 50	6 x 50

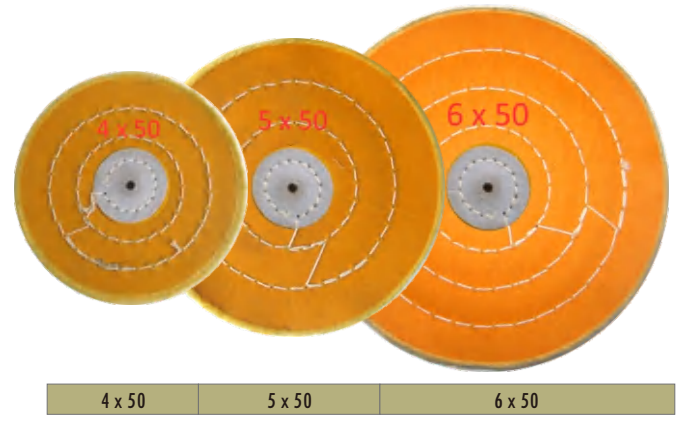

4 x 50	5 x 50	6 x 50
--------	--------	--------

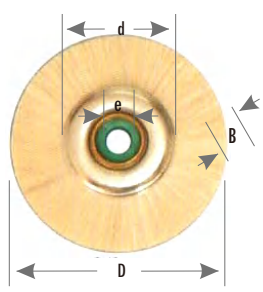

Item	2A	2B	2C	6A	6B	6C	J03	J02	J01	P80	03B48
D	79	73	68	64	60	54	70	58	51	80	48
d	48	48	48	35	35	35	35	30	25	40	25
e	6.5	6.5	6.5	6.5	6.5	6.5	8.5/5	8/5	7/5	6.5	6.35
B	16	16	16	16	16	16	24	16.5	15	36	9
Rows	2	2	2	2	2	2	3	2	1	4	1

Converging      Straight

## Felt Bobs & Burs 毛毡磨头



<b>03N25</b>	<b>03Ns25</b>	<b>3P</b>	<b>2P</b>	<b>1P</b>	<b>1R</b>
25 x 5 mm, 硬质	25 x 5 mm, 软质	15 x 25 mm	20 x 40 mm	22 x 50 mm	22 x 50 mm

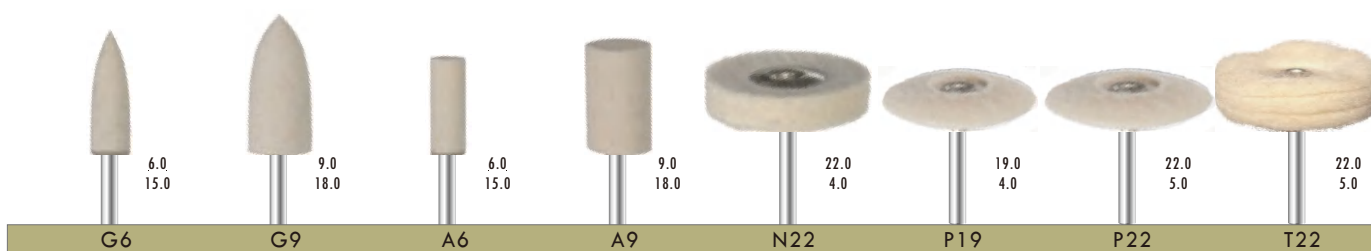

<b>G6</b>	<b>G9</b>	<b>A6</b>	<b>A9</b>	<b>N22</b>	<b>P19</b>	<b>P22</b>	<b>T22</b>
6.0 15.0	9.0 18.0	6.0 15.0	9.0 18.0	22.0 4.0	19.0 4.0	22.0 5.0	22.0 5.0

## Mandrels Stainless Reinforced 不锈钢夹针

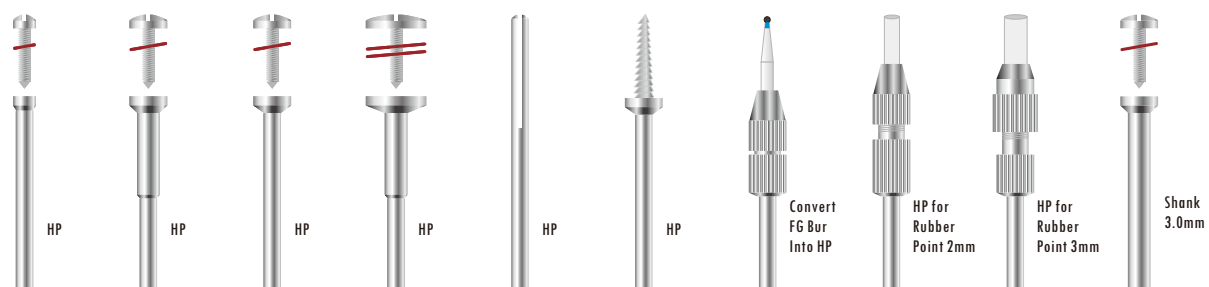

编号 No.	<b>32HS</b>	<b>51HS</b>	<b>52HS</b>	<b>81HS</b>	<b>25HS</b>	<b>53HS</b>	<b>55HS</b>	<b>D20HS</b>	<b>D30HS</b>	<b>52D</b>
Head size	3.0mm	5.0mm	5.0mm	8.0mm	2.5mm	5.0mm	5.0mm	5.0mm	6.0mm	5.0mm

## Mandrels Steel 普通夹针

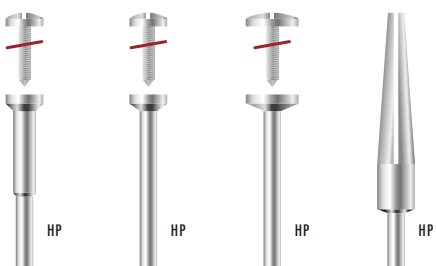

编号 No.	<b>51H</b>	<b>52H</b>	<b>72H</b>	<b>54H</b>
Head size	5.0mm	5.0mm	7.0mm	5.0mm

## Hard Z Cutter 硬锆磨头

Made of Nano-grade Zirconia, used to grinding, finishing or polishing Ceramics and Acrylic, Resin, Zirconia etc. Also applied to Soft materials such as wood, Ceramic or stones etc

用于打磨,成型,抛光烤瓷,树脂,氧化锆(烧结前)。特殊的纳米级氧化锆胚体制而成。

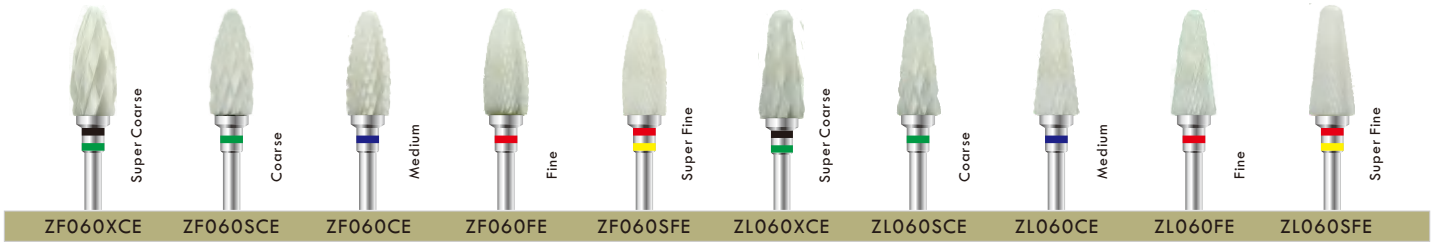
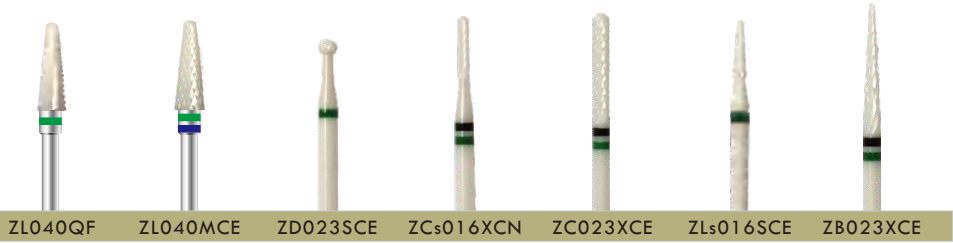

## Sharpening Stones 磨刀石

Adjust to minimum speed;  
Touch the stones softly.  
Using water will be better

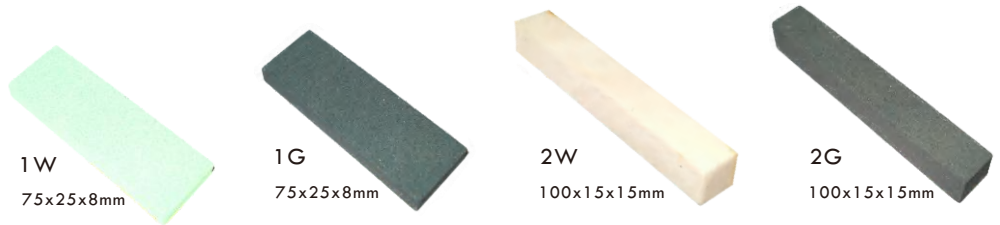

## Cleaning Brushes By Hand 清洁刷(手用)



## Stainless Steel Disc 不锈钢小锯片

for Soft Plastic, Acrylic, Wood etc.



## Stone Disc 刚玉车片

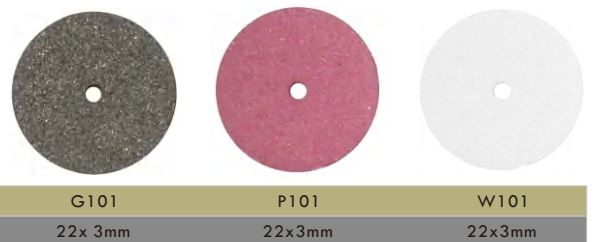

3Z09.1

Zirconia Luster Polishing Kit  
氧化锆抛光套装

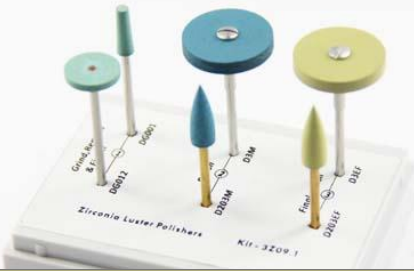

- + 2 pieces of Diamond Stones DG001 , DG012
- + 2 pieces of Diamond Polishers, Blue, D203M, D3M
- + 2 pieces of Diamond Polishers, Yellow, D203EF, D3EF

3Z00.2

Grinding and polishing Kit of Zirconia  
氧化锆打磨抛光套装

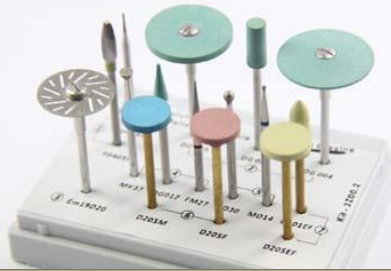

- + 2 pieces of Tungsten carbide Burs HP 699, F040SFE
- + 1 set of Diamond Disc Em19D20 Mounted
- + 4 pieces of HP Diamond Burs: MK37, FM27, FD30, MD14
- + 4 pieces of Diamond Stones: DG017, DG002, DG004, DG005
- + 4 pieces of Diamond Polishers: D205M, D205F, D205EF, D201EF .

3Z00.3

Grinding and Polishing Kit for Zirconia  
氧化锆打磨抛光套装

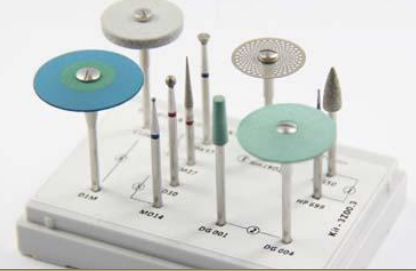

- + 1 piece HP Tungsten Carbide Burs HP 699
- + 5 pieces Diamond Burs: MG50, MD14, FD30, FM27, MK37 ;
- + 1 set of Diamond Disc Hm19D20 Mounted
- + 1 piece of Diamond Polisher D1M
- + 1 set of Silicon polisher C104C Mounted

3L04.2

Grinding and Polishing Kit for Lithium Disilicate  
玻璃陶瓷打磨抛光套装

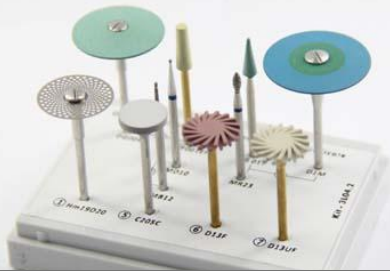

- + 1 set of Diamond Disc Hm19D20, Mounted ,
- + 3 pieces of Diamond Stones DG017 , DG004, DY001EF
- + 3 pieces of HP Diamond Burs MD10, MB12, MR23
- + 3 piece of Diamond Polisher D1M, D13F, D13UF
- + 1 piece of Silicon Polisher C205C

3L04.3

Grinding and Polishing Kit for Lithium Disilicate  
玻璃陶瓷打磨抛光套装

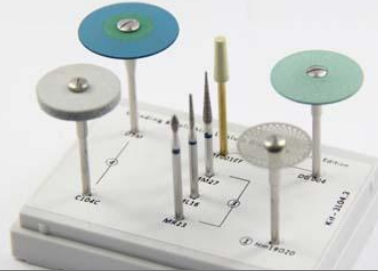

- + 1 set of Diamond Disc Hm19D20, Mounted ,
- + 2 pieces of Diamond Stones DG004, DY001EF ,
- + 3 pieces of HP Diamond Burs MR23, ML16, MM27 ,
- + 1 piece of Diamond Polisher D1M
- + 1 piece of Silicon Polisher C205C

3MC02.3

Adjusting and Polishing Kit for Ceramics  
烤瓷工件打磨抛光套装

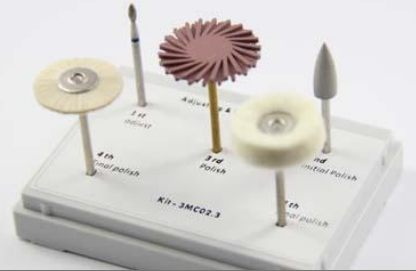

- + 1 piece of HP Diamond Burs MR23
- + 1 piece of HP Silicon Polisher C203C
- + 1 piece of Diamond Polisher D26f
- + 2 pieces of Polishing Brushes 01G22 , N22

3MR09.1

Adjust & Polish Invisible Braces  
隐形牙套调整抛光套装



- + 1 piece of Tungsten Carbide Burs AL02354
- + 1 set of Diamond Disc C19D20, Mounted
- + 2 pieces of Polishing Brushes 01Ms25 , 01S22



### 3A00.1

Popular HP Kit for grinding or polish Metal or Alloy  
常用打磨抛光金属、合金的套装



- \* Universally grind, remove, polish and finish of Alloy, metal, Jewellery, stones etc. It widely applied to Laboratory, DIY or Hobbies.
- + 5 pieces of HP sintered diamond burs ,
- + 4 pieces of HP Tungsten Carbide Cutters
- + 10 pieces of HP Tungsten Carbide burs
- + 4 pieces of White stones
- + 2 pieces of Pink stones
- + 10 pieces of HP Silicon Polishers
- + 3 pieces of Rubber wheel mounted
- + 1 pieces of Woolen Felt wheel mounted ,
- + 5 pieces of HP Polishing brushes

### 3MC00.1

Popular HP Kit for grinding or polish Ceramics / Porcelain  
常用打磨抛光陶瓷的套装



- \* Universally grind, remove, polish and finish of Ceramics or Porcelains etc. It widely applied to Laboratory, DIY or Hobbies.
- + 10 pieces of HP Diamond burs ,
- + 4 pieces of Diamond Discs mounted
- + 6 pieces of HP Green Stones
- + 3 pieces of Silicon Rubber wheel mounted
- + 8 pieces of Silicon Rubber Polishers
- + 4 pieces of Polishing brushes

### 3LR00.1

Popular HP Kit for grinding or polish Acrylic, Resin  
常用打磨抛光树脂胶托的套装



- \* Universally grind, remove, polish and finish of Acrylic, Resin etc. It widely applied to Laboratory, DIY or Hobbies.
- + 2 pieces of HP Tungsten Carbide Cutters
- + 3 pieces of HP Silicon rubber Polishers
- + 10 pieces of Polishing brushes
- + 3 pieces of Woolen Felt polishing brushes

### 3Z00.1

Popular HP Kit for grinding or polish Zirconia, Lithium Disilicate  
常用打磨抛光氧化锆、玻璃陶瓷的套装



- \* Universally grind, polish and finish of Zirconia and Lithium Disilicate etc. It widely applied to Laboratory, DIY or Hobbies.
- + 4 pieces of HP Diamond Burs
- + 2 pieces of Diamond Discs Mounted
- + 6 pieces of Diamond Stones
- + 4 pieces of Diamond polishing wheels
- + 2 pieces of Diamond polishing burs
- + 5 pieces of Diamond Twist polishers
- + 1 pieces of Polishing brush .

### ZS100

Hot HP Mounted stones mixed  
车石套装,常用。



- \* 100 Pcs, Hot Mounted stones in Green, Pink, White , applied to Alloy, metal, ceramics, Jewellery, stones, hard wood etc.
- + 30 pieces of HP Green Stones
- + 30 pieces of HP Pink Stones
- + 30 pieces of White Stones
- + 10 pieces of Brown Stones

### ZD 101

Popular HP diamond burs KIT  
常用金刚石磨头套装

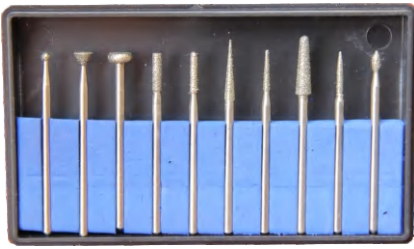

MD23, MK47, MJ60, MA23, MC18, MM27, MB21, ML40, MG16, MR23

10 Hot Spec. of HP Diamond, universally grind, remove, polish and finish of Alloy, metal, Jewellery, stones etc. It widely applied to Laboratory, DIY or Hobbies.

用途: 选取10支最常用的金刚石磨头, 形状全, 大小适中, 可以用来处理陶瓷工件。

### ZD 101F

Popular HP diamond burs KIT  
常用金刚石磨头套装

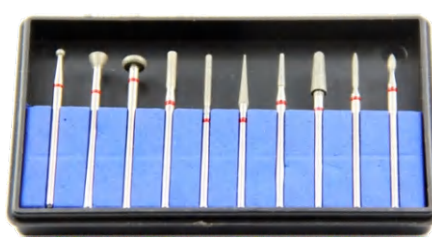

FD23, FK47, FJ60, FA23, FC18, FM27, FB21, FL40, FG16, FR23

10 Hot Spec. of HP Diamond of Fine grit, universally grind, remove, polish and finish of Zirconia, Lithium Disilicate, Porcelain etc. It widely applied to Laboratory, DIY or Hobbies.

用途: 选取10支最常用的金刚石磨头, 形状全, 大小适中, 可以用来处理氧化锆、玻璃陶瓷、烤瓷等工件。

### ZD 102

Small & Tiny Cut, HP diamond burs KIT  
金刚石磨头, 小号套装

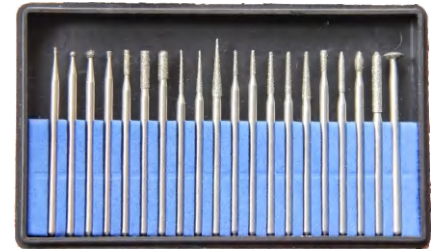

MD10, MD14, MD23, MK16, MA16, MA23, MC25, MM12, MM18, MM27, MB12, MB16, MB21, ML16, ML23, MN18, MG16, MR23, MQ23, MU50.

20 Spec. small or sharp burs. To create tiny hole, slim curves or tiny, deep grind smartly. Used to Alloy, metal, ceramics, Jewellery, stones, hard wood etc. It widely applied to Laboratory, DIY or Hobbies.

用途: 20支金刚石磨头, 用来开小洞, 细边, 细槽, 或者小的磨削。很轻巧, 灵活。适用于各种金属, 合金, 陶瓷, 珠宝, 宝石, 木头等。

### ZD 103

Fast Trimming, HP diamond burs KIT  
金刚石磨头套装, 快速磨削



CQ23, CL40, SD35, SA50, SC40, SP70, SG50, SV70, SV60, SF60

20 Spec. HP Diamond for fast trimming, Grinding of Plastic, Jewellery, stones, Hard wood, etc. Save time when removing and work efficiently. 用途: 10支常用的金刚石磨头, 头部相对比较大, 可以快速磨削塑料, 木头, 陶瓷和石头等等, 适用于牙科, 珠宝加工和DIY爱好者。

### ZD 104

Hot Fully-Sintered diamond KITs  
全砂烧结磨头套装, 常用



C 050S, F050S, L050S, B050C, A037, G050, C037F, F050F, M050EF, G050EF

10 spec. Hot Fully-sintered Diamond HP burs, universal grind, remove, polish and finish of Alloy, metal, Jewellery, stones etc. It widely applied to Lab, DIY or Hobbies.

用途: 10个常用全砂烧结磨头, 5种不同粗细。广泛适用于研磨, 抛光金属, 合金, 珠宝, 宝石。经久耐用, 方便实惠。

### ZD 105

Fast Trimming Fully-Sintered diamond KIT  
全砂烧结磨头套装, 大磨削



K080S, K100S, J100S, C070S, M070S, B070S, L070S, G060S, F070S, R070S

If workpieces are extremely hard and waste too much time when grinding, this fast trimming kit may help to work efficiently. Applied to Alloy, metal, Jewellery, stones, hard wood, etc.

用途: 10个大头的全砂烧结磨头, 用于粗磨, 去块, 效率高, 经济实惠。

### ZT 101

Popular HP Tungsten carbide burs KIT  
常用低速钨钢针



HP 1/4, HP 1/2, HP 1, HP 2, HP 3, HP 4, HP 5, HP 8, HP 34, HP 36, HP 38, HP 41, HP 556, HP 557, HP 560, HP 563, HP 699, HP 701, HP 702, HP 704

20 Spec. HP Tungsten Carbide burs are used to create tiny hole, slim curves or tiny, deep grind very smartly. It is applied to Alloy, metal, ceramics, Jewellery, stones, hard wood etc.

用途: 20个型号钨钢车针, 用于雕牙花, 钻小孔, 洞, 开细槽, 细线等, 金属, 合金, 宝石, 坚木都可以用。

### ZT 102

Hot Tungsten carbide cutters Kit  
钨钢磨头套装, 常用



D050SP, L040SC, L060SC, F060SC, B023SC, L023SC, L040FC, C023FC, L040EFC, F060CC

10 spec. Tungsten carbide Cutter, universal grind, remove, polish and finish of Acrylic, Resin, stones, soft metal or wood.

用途: 10个常用钨钢磨头, 形状全, 大小适中。主要用来研磨, 抛光塑料, 树脂, 软金属, 石头等, 方便实惠。

### ZF 101

Acrylic Polishing Kit  
树脂基托抛光套装



F060SC, L040SC, U12 x 2, U13 x 2, U16 x 2

Simple and straight way to adjust Acrylic without the problem associated with pumice.

用途: 2个型号的钨钢磨头快速磨削, 三个不同粒度的硅胶磨头依次进行抛光。

### ZA 101

Non-precise metal, Alloy Adjust and polish  
非贵金属, 铬钴调整与抛光



W-01, W-09, W-08, W-16, W-03, W-06  
A201C, A203C, A206C, A201F, A203F

To adjust and polish Cobalt-chromium, nickel chromium Alloy. White stones for adjusting or grinding, Rubber burs for polishing.

用途: 试用于铬钴、镍铬合金等非贵金属的研磨和抛光 6支白车石用来研磨和调整, 5支硅胶磨头用来抛光。

### ZP 100

Sandpaper Polishing burs Kit  
砂纸棒套装



240#, 400#, 600#, 800#, 1000#, 1500#, 2000#, 2500#, 3000#, 5000#

10 different Grit Sandpaper burs are used for polishing Alloy, metal, Jewellery stones, hard woods etc. Working step by step, mirror surface in coming soon, water cooling or dry are acceptable.

用途: 10个不同粒度的砂纸棒, 从240目到5000目不等, 请根据需要, 选取合适的粒度, 耐心细致地使用。

### Z 2001

Popular Felt Polishing bur Kit  
毛毡抛光磨头套装



12 pieces of High quality Felt polishing burs are widely used to mould, Alloy, metal, Jewellery, stones, Hard woods etc.

12 pieces of High quality Felt polishing burs are widely used to mould, Alloy, metal, Jewellery, stones, Hard woods etc.

用途: 12支常用的毛毡磨头, 广泛适用于各种模具, 金属, 陶瓷, 珠宝, 宝石和木头等。



# Samples Collection

## 样品册

- Flip-Cart Plastic Pages ;
- Smart, Easily fill all burs ;
- Economic and Recyclable ;
- Nice-looking for showing to Customers;
- Convenient to take to anywhere .



### No. 171B5

Empty Collection Wallet  
样品本(不带车针)



4 Colors Available ,  
100 holes per page,  
5 pages per set,  
Smart to HP Burs



### No. 1704D

Sintered Diamond Burs Collection  
全砂烧结磨头样品本



115 specifications ,  
Fully Sintered Diamond,  
HP shanks



### No. 1705D

HP Diamond Burs, Mounted Stones  
金刚石磨头, 车石样品本



More than 100 specifications ,  
Electroplating Diamond burs  
HP Shanks



### No. 1707T

Tungsten carbide Burs Collection  
高品质钨钢磨头样品本



More than 100 specifications ,  
High Quality TC burs,  
HP Shanks



### No. 1708P

Polishing Burs, Mandrels Collection  
抛光磨头, 夹针样品本



More than 100 specifications ,  
Silicon, Rubber, Diamond burs  
HP Shanks





## 隐形义齿胶

### FlexSoft Partial Dentures



The alternative to conventional Partial Dentures ;  
Flexible . Soft. Easy-to-finish. Easy-to-polish  
弹性好, 易成型, 易抛亮, 美观大方。



编号 No.	规格 Spec.
D2	Crystal ; 18 gs
C1	Ligth Pink ; 9 gs
C2	Ligth Pink ; 18 gs
B1	Standard Pink ; 9 gs
B2	Standard Pink ; 18 gs
A1	Deep Pink ; 9 gs
A2	Deep Pink ; 18 gs
For bulk pak of 1 kilo.	
C3	Ligth Pink ; 1000 gs
B3	Standard Pink ; 1000 gs
A3	Deep Pink ; 1000 gs



Crystal (D)  
(透明)



Light pink (C)  
(浅粉红)



Standard pink (B)  
(粉红)



Deep pink (A)  
(深粉红)



### Instructions for Use

Suitable for: Partial and complete dentures, occlusal splints and nightguards.

Not Suitable for: Small unilateral restorations.

Warnings: Use eye protection and heat-resistant gloves when injecting.

Use proper ventilation, vacuum system and masks when grinding prosthodontic resins.

Precautions: Cartridge must be injected within 1 hour of opening the foil pouch.

#### I. PREPARING THE MASTER MODEL FOR DUPLICATION

All undercuts that will affect the path of insertion should be blocked-out with wax prior to duplication. Do not relieve necklines of teeth or areas desirable for retention. For free-end saddles, it is not necessary to remove the distal undercut of the last natural tooth, unless the area is too deep. For free-end saddle cases where anterior teeth are also being replaced, undercuts in the anterior should also be blocked out.

#### II. SET-UP

Duplicate blocked-out master model. Articulate the duplicate model and the master model (you will need the master model articulated at finishing steps to check occlusion). Set up the case on the duplicate model using only wax (no base plate).

Allow 1 mm of thickness under the teeth to flow to the labial side and into the retention diatorics in the teeth. Use a small round carbide bur to create mechanical retention in the teeth, from mesial to distal and connected to the center diatoric hole.

#### III. WAXING

Important: Wax the case with anatomical features to reduce grinding during the finishing stage.

Recommended thickness of wax-up:

1. Palatal thickness 1.2 - 1.5 mm
2. Buccal & Labial Flange 1.2 - 2.0 mm
3. Clasps 1.0 - 1.5 mm
4. Lingual Flange 1.2 - 2.0 mm
5. Lingual Major Connector (Mandibular) 1.7 - 2.0 mm

#### IV. INVESTING AND SPRUING

Invest the case in the center of the flask, aiming the posterior portion toward the sprue opening. After the stone (or plaster) has set, use two sprues from the flask opening to the most posterior portion of the wax on both sides (see diagram). Sprues should be approximately 7 mm. width. Do not create sharp angles with the sprues, as the heated resin must flow in a straight or slightly curved path. Apply a thin layer of petroleum jelly on the entire stone surface. Then invest top half of flask.

#### V. REMOVING WAX

After the stone has set, place flask in boiling water for 8 minutes. Open the flask and wash out the wax, making sure all wax residues are eliminated. Allow the flask to cool. Apply thin layers of separator on the entire surface of the stone and allow it to dry completely. Do not apply separator on teeth. When dry, close flask.

#### VI. INJECTING

Wear safety goggles and heat-protective gloves for this procedure.

Spray inside of the cartridge sleeve with mold release spray and place it into furnace. Turn on the furnace and allow it to reach approximately 550°F (290°C), preheating cartridge sleeve for approximately 15 minutes.

Remove cartridge from foil-lined bag (do not remove cartridge from bag until this step). Spray the cartridge and bronze disc with mold release spray. Insert the cartridge into the cartridge sleeve with the cap end first. Insert the bronze disc into the cartridge sleeve against the end of the cartridge. Use the thick bronze disc for medium tubes and the thin bronze disc for the large tubes. Heat cartridge for 12 minutes.

Position the flask with the sprue end up, directly under the shaft of the press. After 12 minutes, remove the cartridge sleeve from the furnace. Keep the cartridge sleeve in a horizontal position until resting on top of the flask, and then turn the cartridge sleeve into a vertical position. Immediately use the press to inject the heated cartridge into the flask using a steady fast motion. Continue applying pressure until tube bursts and continue with maximum downward pressure for 3 minutes.

Remove the cartridge sleeve from the flask with a slight twisting motion. After removing the cartridge sleeve, let the flask cool for at least 30 minutes. Do not put flask into a cold water bath. Use a plaster nipper to de-flask. Do not use a hammer. Remove the compressed cartridge from the cartridge sleeve with a knock-out punch. Important: Cartridge sleeve must be pre-heated for 10 minutes BEFORE the next injection.

#### VII. FINISHING AND POLISHING

Remove appliance from the model. Cut off the sprues with a cut-off wheel. Trim the edges of appliance with a coarse grinding wheel. Avoid overheating. Use rubber wheels to smooth scratches. Place the appliance on the articulated master model to check the fit, retention, thickness and occlusion. Clean the tissue surface with a small bristle brush.

To polish, use a coarse dental abrasive, such as pumice, with a wet rag wheel. Apply final shine with a hi-shine compound on low speed with a final buff wheel. Be careful not to overheat appliance.

## 铝桶

### Empty Aluminum Cartridge

编号 No.	规格 D x H, mm
25085	25 x 85 mm
25100	25 x 100 mm
25CAP	24.2 x 16 mm, Cap
22065	22 x 65 mm
22085	22 x 85 mm
22100	22 x 100 mm
22120	22 x 120 mm
22CAP	21.2 x 16 mm, Cap





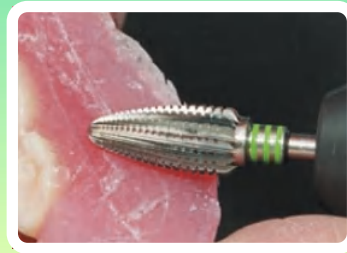
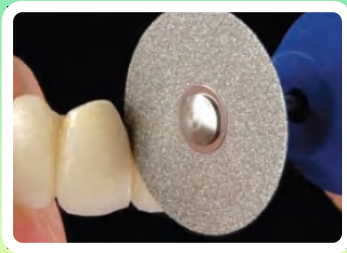

## 深圳市永昌源科技开发有限公司

ShenzhenYongchangyuan Technology Development Co., Ltd

地址: 广东省深圳市龙岗区平湖街道辅城坳社区金城路4号盛通云谷C座3楼

Address : 3rd Floor, Block C, ShengTong YunGu, JinCheng Rd., FuChengAo, PingHu, LongGang Distr., 518000, Shenzhen, Guangdong Province, China

网站(Web): [www.kexinn.com](http://www.kexinn.com) ; 邮箱(Email): [inof@kexinn.com](mailto:inof@kexinn.com)

电话(Tel.): +86-755-89309291

手机(Mobile, Wechat, Whatsapp): +8613823370303 +8613149941313