



Fiber series

Fiber flying laser marking machine

Average output power:

50W



Marking speed
200m/min



No consumables,
long-term maintenance-free

PRODUCT DESCRIPTION

LEAD TECH 50w fiber flying laser printer is a high-speed continuous marking machine designed to improve productivity. It adopts industrial-grade high-performance laser source which are with stable performance, fast processing efficiency and marking speed on the production line. It can reach high speed up to 200 meters per minute (single-line 2MM-high numbers and letters) with high yield application identification requirements, it mainly used in production date, anti-counterfeiting, medical and food packaging industries. This model supports functions such as automatic encoding, serial number, batch number, date, barcode, two dimensional code, automatic number skipping, etc., to meet the needs of customers in different industries.

Fiber laser online marking machine is suitable for online marking of most metal materials and some non-metallic materials with surface treatment, such as metal products, PVC, HDPE, aluminum film, rubber and plastics. It is widely used in the production of personal care products, food and beverage packaging, wine, dairy products, electronic components, chemical building materials and other fields, and the expiration date, batch number, shift, manufacturer name and logo and other graphics and text markings.

PRODUCT CHARACTERISTICS

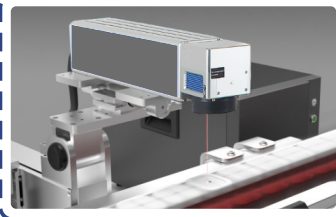

MARKING SPEED UP TO 200 METERS PER MINUTE

This is the industry's fastest marking laser coding system, with a marking speed of up to 200 m/min (single line of 2MM-high numbers and letters), which can be used in medium-speed or high-speed production line

RELIABLE AND DURABLE FIBER LASER SOURCE

It adopts high-quality fiber laser light source, which is in uniform laser power density and highly focused laser beam. Achieved a better logo contrast and the working life of the laser can reach 100,000 hours



COMPACT DESIGN AND FLEXIBLE CONFIGURATION

This model uses compact laser printer marking head to achieve simple integration to reduce installation costs and improve positioning flexibility

FLEXIBLE INSTALLATION WAY, CONVENIENT INSTALLATION POSITION ADJUSTMENT

The flying model is specially designed for high-speed production lines, which can be flexibly combined with production lines for installation and use. The frame can be moved up and down and left and right to adjust, the marking head can also be rotated 360° for marking.

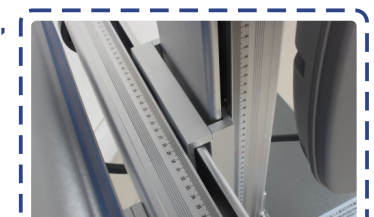

PRODUCT PARAMETER

| Laser Type | | Fiber Laser |
|--------------------|-----------------------------|-------------------------------------------------------------------------------------------------|
| Model | | LT50F |
| Laser parameters | Output Power | 50W |
| | Beam quality M ² | ≤1.6 |
| | Pulse repetition frequency | 45-170 kHz |
| | Laser wavelength | 1064±5 |
| | Output power stability | <3% |
| | Working life | About 100,000 working hours (non-lifetime) |
| Optical properties | Marking range | 100~300mm (range optional) |
| | Engraving depth | ≤1mm (depending on power and time) |
| | Engraving speed | ≤10000mm/s |
| | Repeat accuracy | ±0.002 |
| | Minimum marking line width | 0.1mm |
| | Minimum character height | 0.15mm |
| Use environment | Cooling way | Built-in air cooling |
| | System power supply | 500W / 220V / 50Hz (110V can be connected) |
| | Temperature humidity | 0~40°, 30% RH 85%, air conditioner should be installed when used outside the range |
| | Oil mist condensation | Not allowed |
| Other parameters | Operating system | Fly control system |
| | File format | The software supports text, QR code, barcode, serial number, graphics and other marking content |
| | Dimensions | 660X510X1460 mm |
| | Packing size | Host: 790X740X350mm Column: 1350X350X280mm |
| | Total Weight | About 66kg |

PRODUCT SIZE

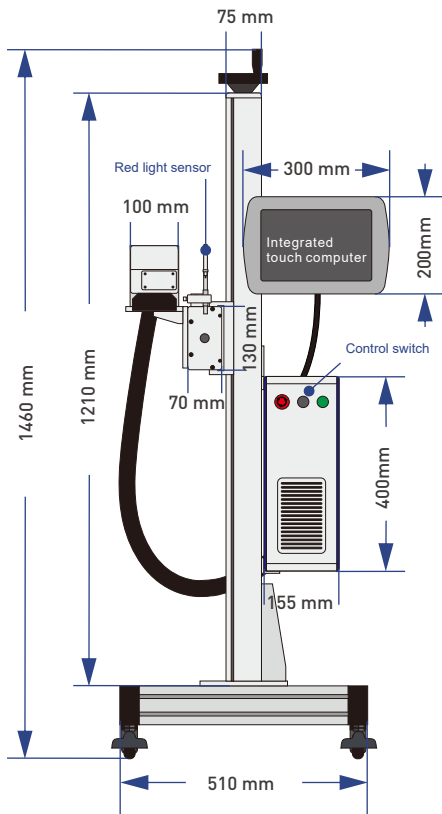

FRONT VIEW

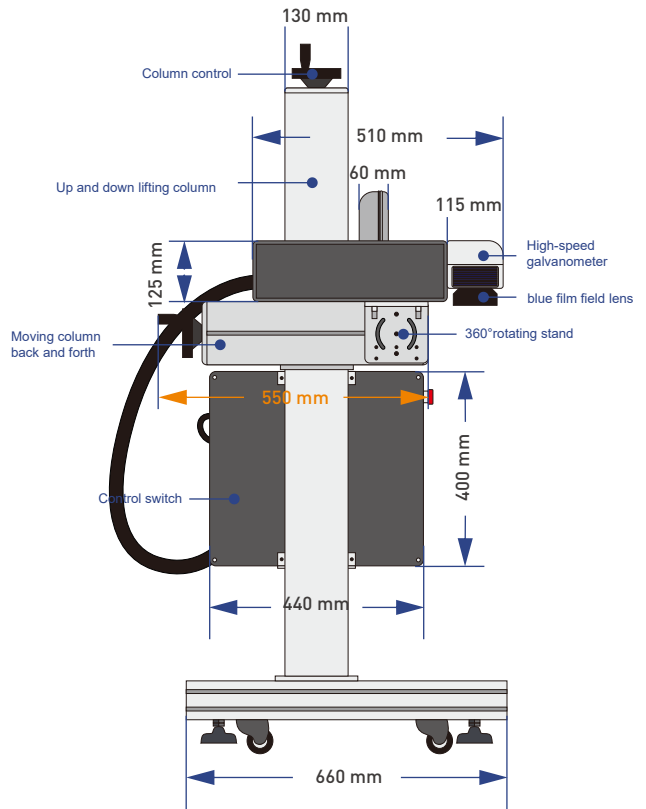

RIGHT SIDE VIEW

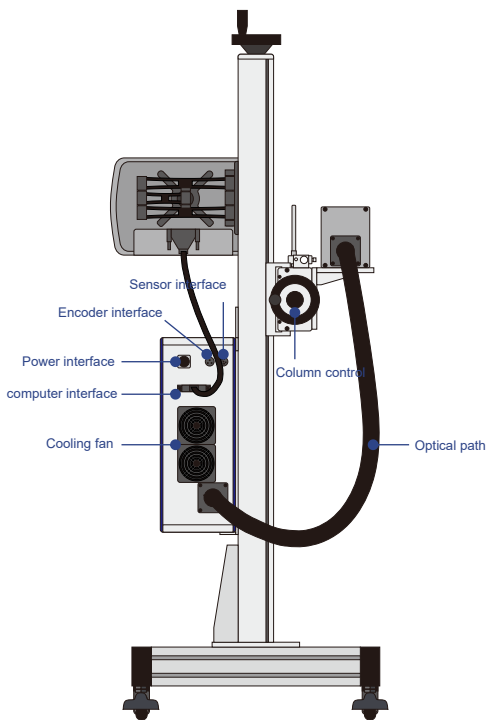

BACK VIEW

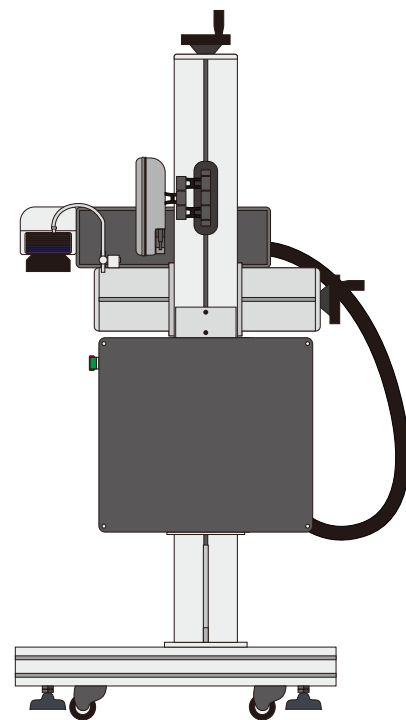

LEFT SIDE VIEW