

User Manual

Hybrid Inverter SSE-HL10-16K-P1EU-S Series

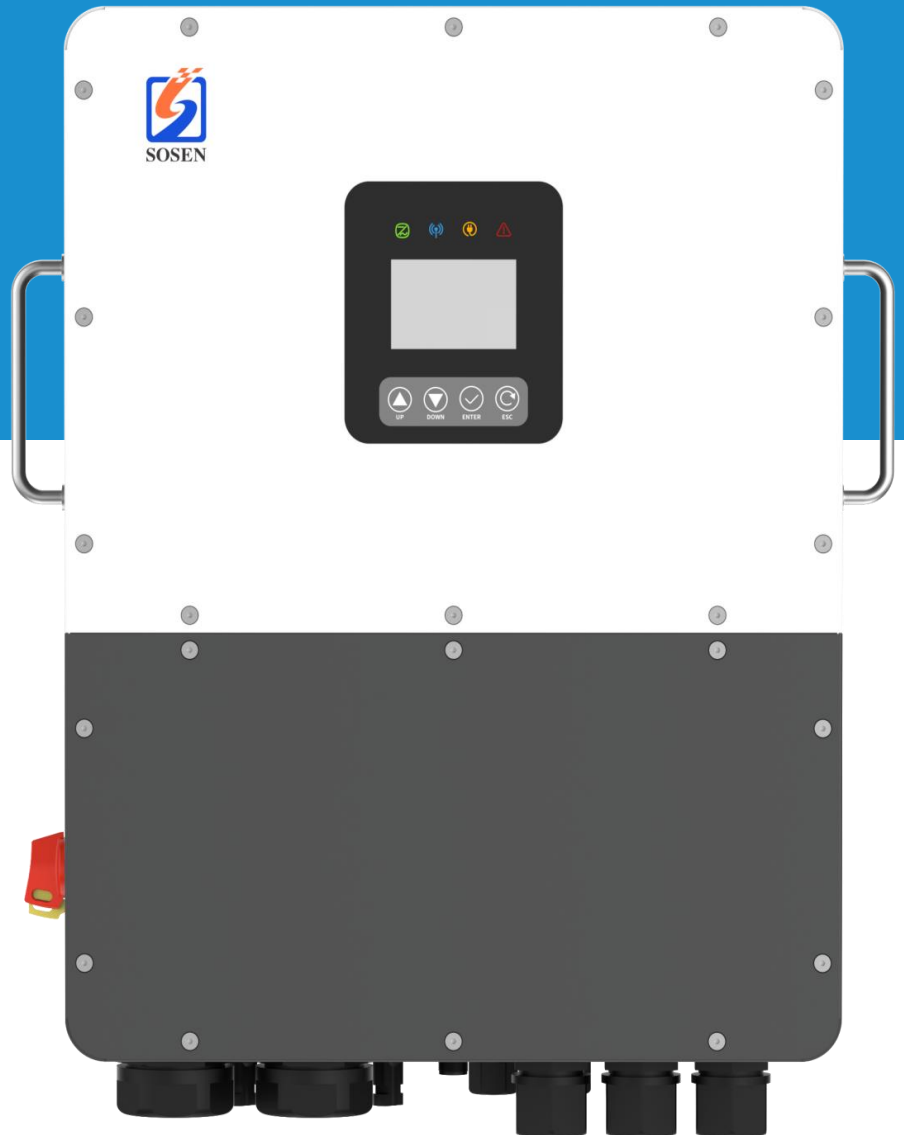

SSE-HL10K-P1EU-S
SSE-HL12K-P1EU-S
SSE-HL14K-P1EU-S
SSE-HL16K-P1EU-S

Please read this manual before use and follow its guidance.
Keep this manual for future reference.

CONTENTS

1. About This Manual	3
1.1 Applicable Model	3
1.2 Target Group	3
1.3 Symbol Definition	3
1.4 Updates	3
2. Safety Precaution	4
2.1 General Safety	4
2.2 PV String Safety	4
2.3 Inverter Safety	5
2.4 Battery Safety	5
2.5 Personal Requirements	6
2.6 EU Declaration of Conformity	6
3. Product Introduction	7
3.1 Product Features	7
3.2 Working Mode	9
3.3 Appearance	10
4. Check and Storage	15
4.1 Check Before Receiving	15
4.2 What's in the box?	15
4.3 Storage	16
5. Installation	16
5.1 Installation Requirements	16
5.2 Inverter Installation	18
6. Electrical Connection	19
6.1 Safety Precaution	21
6.2 Parallel connection notice	21
6.3 Connection Port Description	21
6.4 Connection Requirements	21
6.5 PE Cable Connection	23
6.6 EPS, Grid and Generator Connection	25
6.7 PV Connection	26
6.8 Battery Connection	27
6.9 Communication Cable Installation	29
6.10 CT Connection	32
6.11 Single phase parallel connection system	32
6.12 Wi-Fi&BLE stick installation and trouble shooting	33
7.Operation	36
7.1 Indicator panel	36
7.2 LCD operation flow chart	37
7.3 LCD Display Icons	38
7.4 System Setup Menu	40
7.5 Basic Settings Menu	42
7.6 Work Mode Settings Menu	42
7.7 Battery Settings Menu	45
7.8 Grid Settings Menu	47

7.9 Generator Port Settings Menu	51
7.10 Advanced Settings Menu	53
7.11 Record Menu	56
7.12 Device Info Setup Menu	57
7.13 Factory Setting Menu	58
8.Trouble Shooting	59
9.Maintenance	64
9.1 Power ON the Inverter for first time	64
9.2 Power Off the Inverter	64
9.3 Removing the Inverter	64
9.4 Disposing of the Inverter	65
9.5 Routine Maintenance	65

1. About This Manual

This manual provides essential information about the product, including installation, electrical connections, commissioning, troubleshooting, and maintenance. Please read this manual thoroughly before installing and operating the product. All installers and users should be familiar with the product's features, functions, and safety precautions. Note that this manual may be updated without prior notice. For more details about the product and to access the latest documents, visit <https://www.soseninverter.com>

1.1 Applicable Model





Model	Nominal Output Power	Nominal Output Voltage
SSE-HL10K-P1EU-S	10kW	230V a.c
SSE-HL12K-P1EU-S	12kW	230V a.c
SSF-HL14K-P1EU-S	14kW	230V a.c
SSE-HL16K-P1EU-S	16kW	230V a.c

1.2 Target Group

This manual is intended for qualified and knowledgeable electrical technical personnel who are responsible for hybrid inverter installation and commissioning in the energy storage system and electric system.

1.3 Symbol Definition

The following types of safety instructions and general information appear in this document as described below:

 DANGER	 WARNING	 CAUTION	 NOTICE
“Danger” indicates a hazardous situation with a high level of risk that, if not avoided, will result in death or serious injury.	“Warning” indicates a hazardous situation with a medium level of risk that, if not avoided, could result in death or serious injury.	“Caution” indicates a hazardous situation with a low level of risk that, if not avoided, could result in minor or moderate injury.	“Notice” provides some tips and methods to solve product-related problems to save time.

1.4 Updates

The latest document contains all the updates made in earlier issues.

V1.0 2025-08-15 • First Issue

V2.0 2026-03-18 • Second Issue

2. Safety Precaution

Please strictly follow these safety instructions in the user manual during the operation.

2.1 General Safety



- The information in this user manual is subject to change due to product updates or other reasons. This guide cannot replace the product labels or the safety precautions indications unless otherwise specified. All descriptions here are for guidance only.
- Before installations, must read the user manual.
- All installations should be performed by trained and knowledgeable technicians who are familiar with local standards and safety regulations.
- Use insulating tools and wear personal protective equipment when operating the equipment to ensure personal safety. Wear anti-static gloves, clothes, and wrist strips when touching electronic devices to protect the inverter from damage.
- Strictly follow the installation, operation, and configuration instructions in this manual. The manufacturer shall not be liable for equipment damage or personal injury if you do not follow the instructions, For more warranty details, please visit <https://www.soseninverter.com/>.

2.2 PV String Safety



Connect the DC cables using the delivered PV connectors. The manufacturer shall not be liable for the equipment damage if other connectors or terminals are used.



- Ensure the component frames and the bracket system are securely grounded.
- Ensure the DC cables are connected tightly, securely and correctly.
- Measure the DC cables with a multimeter to avoid reverse polarity connection. Also, the voltage should be under the permissible range.
- Do not connect one PV string to more than one inverter at the same time. Otherwise, it may cause damage to the inverter.
- The PV modules used with the inverter must have an IEC61730 class A rating.
- When the photovoltaic array is exposed to light, it supplies a DC voltage to the inverter.

2.3 Inverter Safety



- The voltage and frequency at the connecting point should meet the on-grid requirements.
- Additional protective devices like circuit breakers or fuses are recommended on the AC side. Specification of the protective device should be at least 1.25 times the AC rated output current.
- Make sure that all the groundings are tightly connected. When there are multiple inverters, ensure that all cabinet grounding points are equipotentially grounded.
- Off-grid function is not recommended if the PV system is not configured with batteries. Otherwise, the risk in system power usage is beyond the equipment manufacturer's warranty scope.
- If the battery is not connected, the instability characteristics of photovoltaic energy must be considered and it must also be noted that the EPS function is not available.

DANGER			
<ul style="list-style-type: none"> • All labels and warning marks should be visible after the installation. Do not cover, scrawl, or damage any label on the equipment. • Warning labels on the inverter are as follows: 			
	DANGER High voltage hazard. Disconnect all incoming power and turn off the product before working on it.		Delayed discharge. Wait 5 minutes after power off until the components are completely discharged.
	Read through the user manual before working on this device.		Potential risks exist. Wear proper PPE before any operations.
	High-temperature hazard. Do not touch the product under operation to avoid being burnt.		Grounding point.
	With CE mark, the inverter fulfills the basic requirements of the guideline governing Low-Voltage and electron-magnetic compatibility.		Do not dispose of the inverter as household waste. Discard the product in compliance with local laws and regulations or send it back to the manufacturer.
	UKCA marking Indicates that it meets UK product safety certification requirements.		RCM marking

2.4 Battery Safety



- The battery used with the inverter shall be approved by the inverter manufacturer. The approved battery list can be obtained through the official website .
- Before installations, read through the corresponding battery's User Manual to learn about the product and the precautions. Strictly follow its requirements.
- If the battery is completely discharged, please charge it strictly following the User Manual of the corresponding model.
- Factors such as temperature, humidity, weather conditions, etc. can limit the battery current and affect its charging.
- Contact after-sale service immediately if the battery is not able to be started. Otherwise, the battery might be damaged permanently.
- Use the multimeter to measure the DC cable to avoid reverse polarity connection. Also, the voltage should be under the permissible range.

2.5 Personal Requirements

NOTICE

- Personnel who install or maintain the equipment must be strictly trained, learn about safety precautions and correct operations.
- Only qualified professionals or trained personnel are allowed to install, operate, maintain, and replace the equipment or parts.

2.6 EU Declaration of Conformity

Shenzhen SOSEN Innovation Technology Co., Ltd. hereby declares that the inverter with wireless communication modules sold in the European market meets the requirements of the following directives:

- Radio Equipment Directive 2014/53/EU (RED)
- Restrictions of Hazardous Substances Directive 2011/65/EU and (EU) 2015/863 (RoHS)
- Waste Electrical and Electronic Equipment 2012/19/EU
- Registration, Evaluation, Authorization and Restriction of Chemicals (EC) No 1907/2006 (REACH)

You can download the EU Declaration of Conformity on our website .

3. Product Introduction

3.1 Product Features

Intended usage

SSE-HL10-16K-P1EU-S series hybrid inverters are used for energy storage systems with battery, load and grid. The energy produced by the PV system will be used to optimize self-consumption, the excess energy will charge the battery and the rest energy can be fed into the grid. The battery will be discharged to support loads when the PV power is insufficient to meet self-consumption. If both the PV power and battery power are insufficient, the system will take power from the grid to support loads. The working mode depends on the PV power and user preference.

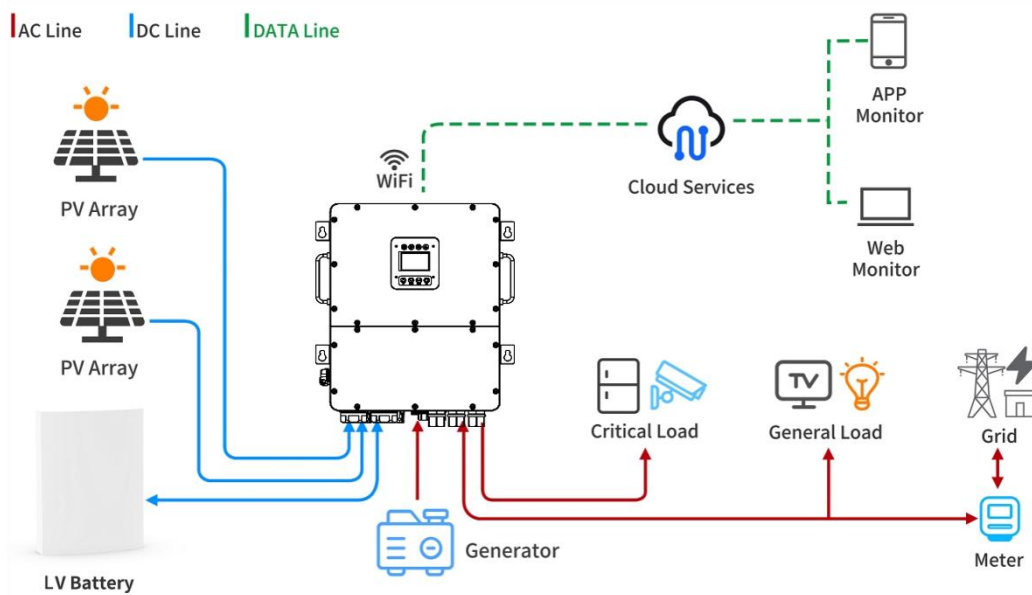

Model

This manual applies to the listed inverters below:

SSE-HL10K-P1EU-S, SSE-HL12K-P1EU-S, SSE-HL14K-P1EU-S, SSE-HL16K-P1EU-S,

Model description

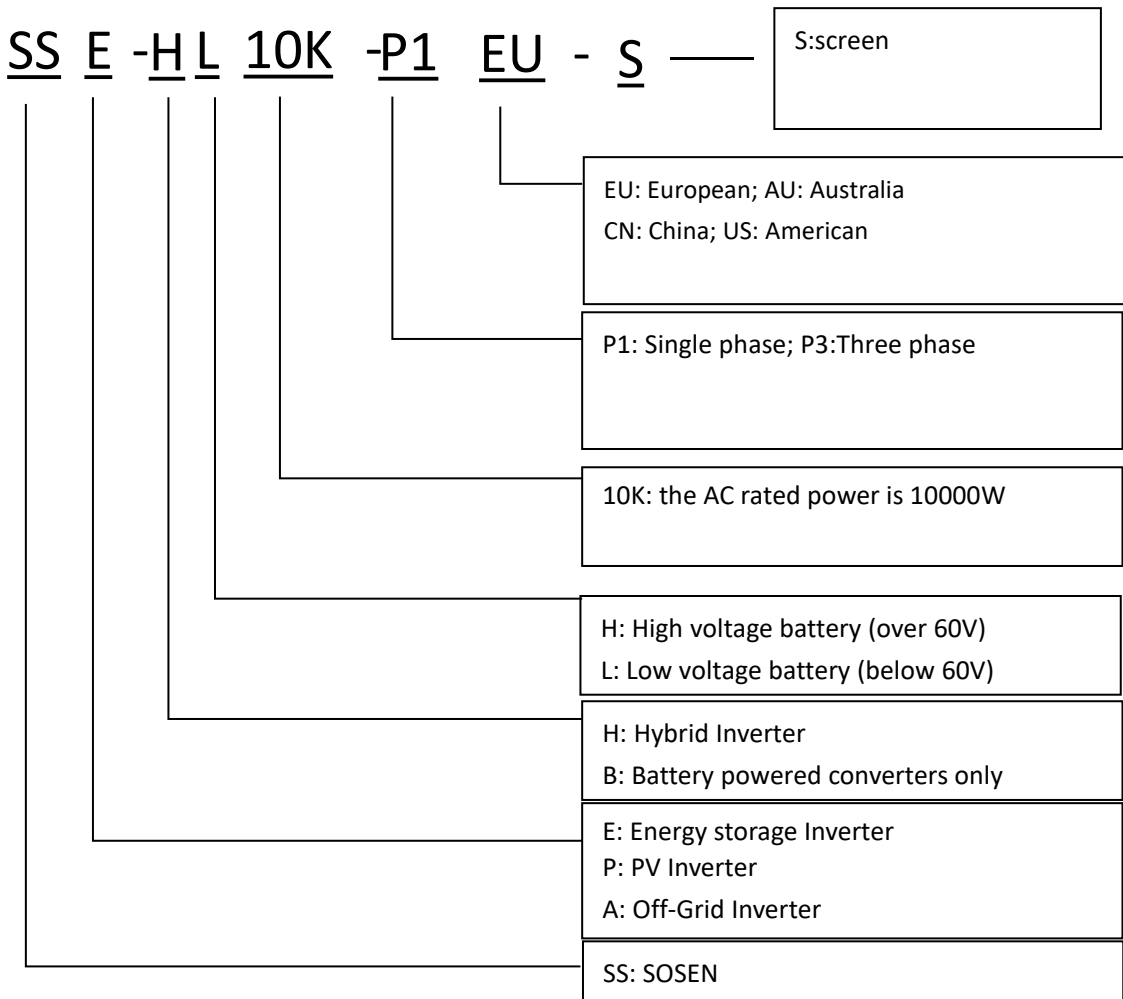

Series Code:

SN: SXXXXXXXX2401100001

Series Code description

No.	Referring to	Code	Description
1	Brand name	S	SOSEN
2	Product category	XXXXXXXX	Inverter model ID
3	Production date	24	The year of Production
4	Production date	01	The month of Production
5	Production date	11	The day of Production
6	Production serial number	00001	

3.2 Working Mode

The SSE-HL10-16K-P1EU-S Series hybrid inverter has the following work modes based on your configuration and layout conditions.

Work modes	Description
Self Use (with PV Power)	Priority: Load > Battery > Grid The energy produced by the PV system is used to optimize self-consumption. The excess energy is used to charge the batteries and then exported to the power grid.
Self Use (without PV Power)	Priority: Load > Battery When no PV supplied, battery will discharge for local loads firstly and grid will supply power when the battery capacity is not enough.
TOU ¹ Eco	This mode can be used to optimize the use of peak and valley prices of the electricity tariff and achieve maximum economic benefit when there are large differences between the prices of one and the other. Peak price: The battery is discharged at full power to sell electricity to the grid at a high price Flat price: Run the standard self-use mode. Valley price: Buy electricity from the grid at a low price to charge the battery at full power
Back up only	Priority: Load > Battery When entering this mode, the system will start to charge the battery until it is fully charged and remains fully charged, waiting for the power grid to fail. When the grid is off, the system will supply emergency power from PV or battery to supply the home loads .
Grid Priority	Priority: Load > Grid When the system works in this mode, the electricity generated by the photovoltaic power will be preferentially injected into the power grid. Users can send requests to the grid during peak hours, and in this mode, they can set the end point of SOC (State Of Charge of the battery).

1) TOU = Time of use



Make sure the load power connected to the EPS output is within the output power of EPS. Otherwise, the inverter will shut down with an "overload" warning. When "overload" appears, adjust the load power, make sure it is within the range of EPS output, and turn on the inverter. For non-linear load, pay attention to the input power, make sure it is within the range of EPS output.

3.3 Appearance

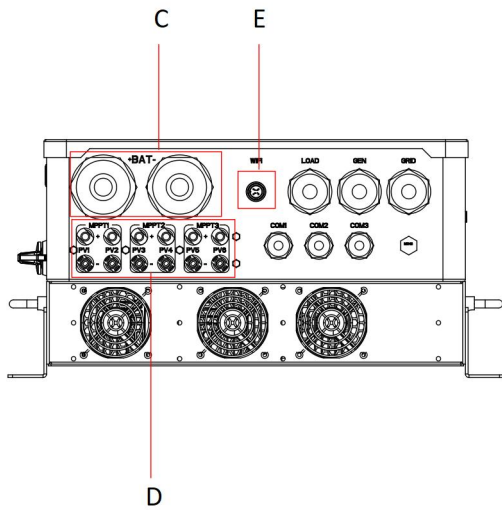

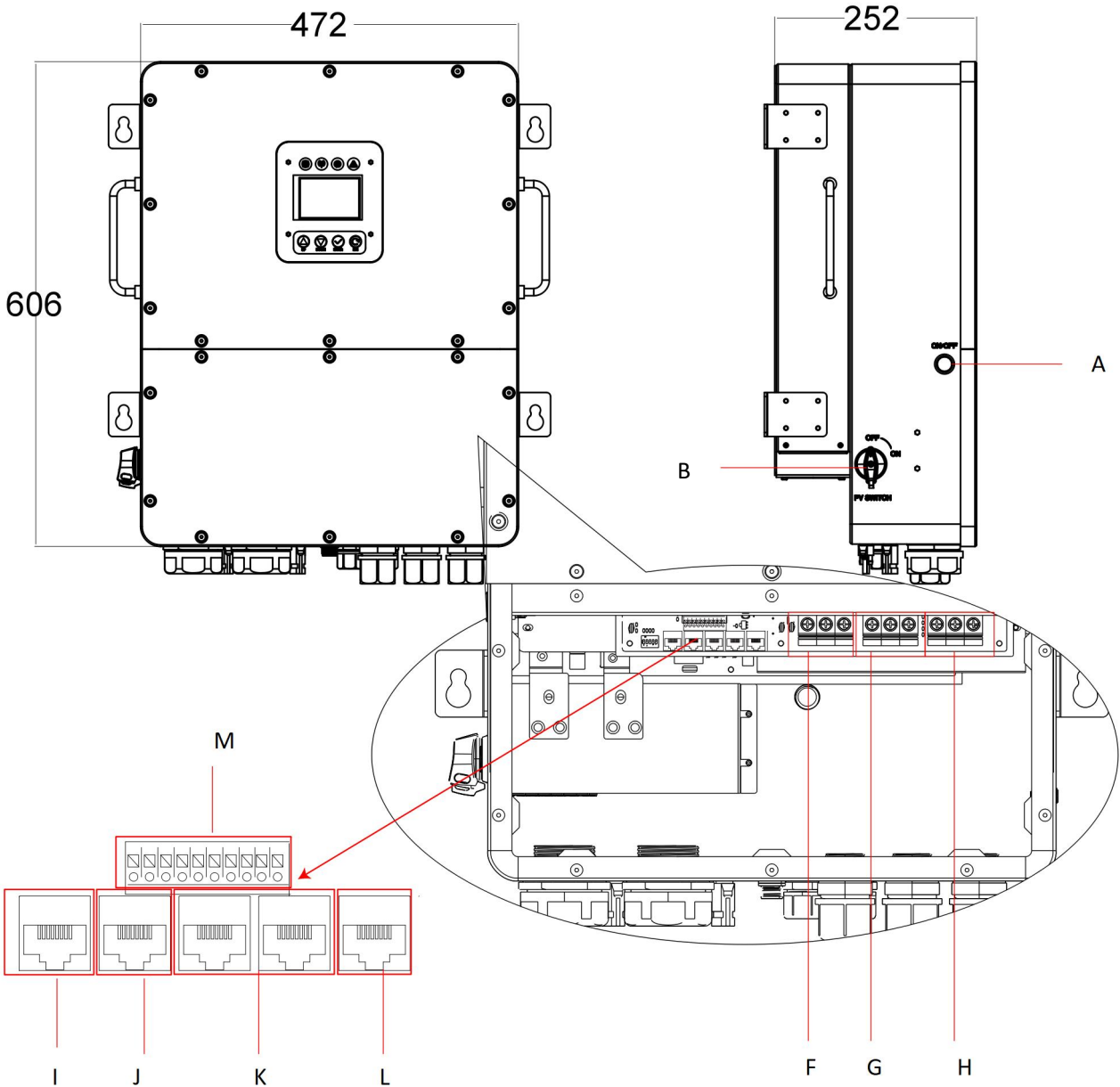

Item	Description	Item	Description
A	Power on/off	H	Generator terminal
B	PV switch	I	DRY/Debug
C	BAT	J	BMS:CAN/485
D	PV connector	K	Parallel port
E	WIFI	L	DRM port
F	Grid terminal	M	Function port
G	EPS terminal		



3.3.3 Nameplate

The nameplate is for reference only.

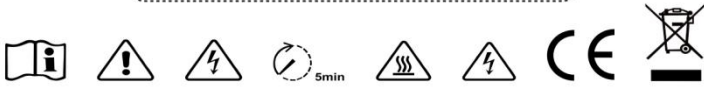
		<h1>Hybrid Inverter</h1>	
SOSEN		Model: SSE-HL16K-P1EU-S	
PV Input			
Max. PV Input Voltage		550V d.c	
MPPT Voltage Range		120~520V d.c	
Max. Input Current		26A d.c*3	
Isc PV		39A d.c*3	
Battery			
Voltage Range		40~60V d.c	
Max.Charge/Discharge Current		275A d.c	
Battery Type		Li-ion/Lead-acid	
Grid			
Rated Voltage		230V a.c,L+N+PE	
Rated Frequency		50/60Hz	
Rated AC Input/Output Current		69.6A a.c	
Rated Output Power		16kW	
Power Factor		0.8Leading~0.8Lagging	
Load			
Rated Voltage		230V a.c,L+N+PE	
Rated Frequency		50/60Hz	
Rated Output Current		69.6A a.c	
Rated Output Power		16kW	
Generator			
GEN Rated Input Current		69.6A a.c	
GEN Rated Input Power		16kW	
General Parameter			
Inverter Topology		Non-isolated	
Protective Class		I	
Ingress Protection		IP66	
Operating Temperature		-25°C~+60°C	
Oversoltage Category		III [AC] , II [DC]	
Shenzhen SOSEN Innovation Technology Co.,Ltd Room 601,Pengzhanhui No 1 Building, Zhongxin Road No 233, Xinqiao Community, Xinqiao Street, Baoan District, Shenzhen, China			
			
			
Made in China			

3.3.4 Features

- Intelligent energy management
- High efficiency
- Compatible with on grid and off grid
- High Sealed design With IP66
- Multiple operating modes are available
- Wide range of battery charge and discharge current
- High speed on/off grid switching

3.3.5 Specification

Model	SSE-HL10K -P1EU-S	SSE-HL12K -P1EU-S	SSE-HL14K -P1EU-S	SSE-HL16K -P1EU-S
Product Type	Hybrid Inverter			
Battery				
Battery Type	Lithium/lead-acid			
Battery Voltage range	40-60V d.c			
Rated Battery Voltage	51.2V d.c			
Max Charge Current	220A d.c	250A d.c	275A d.c	275A d.c
Max Discharge Current	220A d.c	250A d.c	275A d.c	275A d.c
BMS Communication	CAN/RS485			
PV Input				
Recommended Max. PV array power	15000W	18000W	22500W	22500W
Max. operating PV input current (PV 1 / PV 2/PV3)	26/26/26 A d.c			
Max. Isc PV (PV 1 / PV 2/PV3)	39/39/39 A d.c			
Vmax PV (Max. PV input voltage)	550V d.c			
PV input operating voltage range	80-520V d.c			
MPPT Voltage Range	80-480V d.c			
Start-up Voltage	120V d.c			
Number of MPPT Trackers	3			
Strings per MPPT Tracker	2			
Number of PV input	6			
Grid AC input and AC output				
Grid rated voltage	220/230/240V.A.C., L+N+PE			
Grid rated frequency	50/60Hz			
Grid rated input active power	10000W	12000W	14000W	16000W
Grid rated input apparent power	10000VA	12000VA	14000VA	16000VA
Grid Max. input active power	10000W	12000W	14000W	16000W
Grid Max. input apparent power	10000VA	12000VA	14000VA	16000VA
Grid rated output active power	10000W	12000W	14000W	16000W
Grid rated output apparent power	10000VA	12000VA	14000VA	16000VA
Grid Max. output active power	10000W	12000W	14000W	16000W
Grid Max. output apparent	10000VA	12000VA	14000VA	16000VA

power

Grid rated input current	43.5Aac	52.2Aac	60.9Aac	69.6Aac
Grid rated output current	43.5Aac	52.2Aac	60.9Aac	69.6Aac
Grid power factor	0.8 leading to 0.8 lagging			
Total Harmonic Distortion (THDi, rated power)	<3%			

EPS Output

EPS rated output Voltage	220/230/240V a.c, L+N+PE			
EPS rated output frequency	50/60Hz			
EPS rated output active power	10000W	12000W	14000W	16000W
EPS rated output apparent power	10000VA	12000VA	14000VA	16000VA
EPS rated output current	43.5Aac	52.2Aac	60.9Aac	69.6Aac
EPS output power factor	0.8 leading to 0.8 lagging			
EPS output peak power	200% overload(<10s)			
EPS Max. output overcurrent protection	250Vac /100 Aac			
Switch Time	<10ms			
Total Harmonic Distortion (THDv, linear Load)	<3%			
Compatible with the Generator	Optional			

Efficiency

MPPT Efficiency	99.90%
Euro-efficiency	97.00%
Max. efficiency	97.80%

Standard

Safety	EN/IEC 62109-1/2, EN/IEC 60529, EN/IEC 62040-1
EMC	EN IEC 61000-6-1, EN IEC 61000-6-3, EN IEC 61000-3-12, EN IEC 61000-3-11, EN IEC 61000-3-2, EN 61000-3-3
Grid-interactive	CEI 0-21, EN 50549-1, VDE-AR-N 4105, UNE 217002, NTS TYPEA, G99, AS/NZS 4777.2 etc.

General Data

Degree of ingress protection	IP66
Protection class	I
Environment category	Outdoor
Wet location classification	Yes
Pollution degree	PD3
Operating altitude	<4000 m
Operating ambient temperature	-25 to +60 °C (lineal derating to 60% when exceeding +45 to +60 °C)
Operating relative Humidity	0-100% (non-condensing)

Storage Temperature	-25- +60 °C
Storage relative Humidity	0-100% (non-condensing)
Noise Emission(typical)	<50db
Overvoltage Category	AC: III, PV: II
Electrical supply system	TN, TT
Dimension (WxHxD)	750x466x242mm
Net Weight	45kg
Cooling Mode	Intelligent Air Cooling
Topology	Non-isolated
Active anti-islanding method	Active frequency drift
Communication with Meter	RS485
Communication with Portal	Bluetooth/WIFI (Optional)/CAN/RS485
Display	LCD+LED

4. Check and Storage

4.1 Check Before Receiving

Check the following items before receiving the product.

1. Check the outer packing box for damage, such as holes, cracks, deformation, and other signs of equipment damage. Do not unpack the package and contact the supplier as soon as possible if any damage is found.
2. Check the inverter model. If the inverter model is not what you requested, do not unpack the product and contact the supplier.
3. Please check that the product model is correct, that the contents are complete and that it is in perfect condition. Contact the supplier as soon as possible if you detect any damage.

4.2 What's in the box?

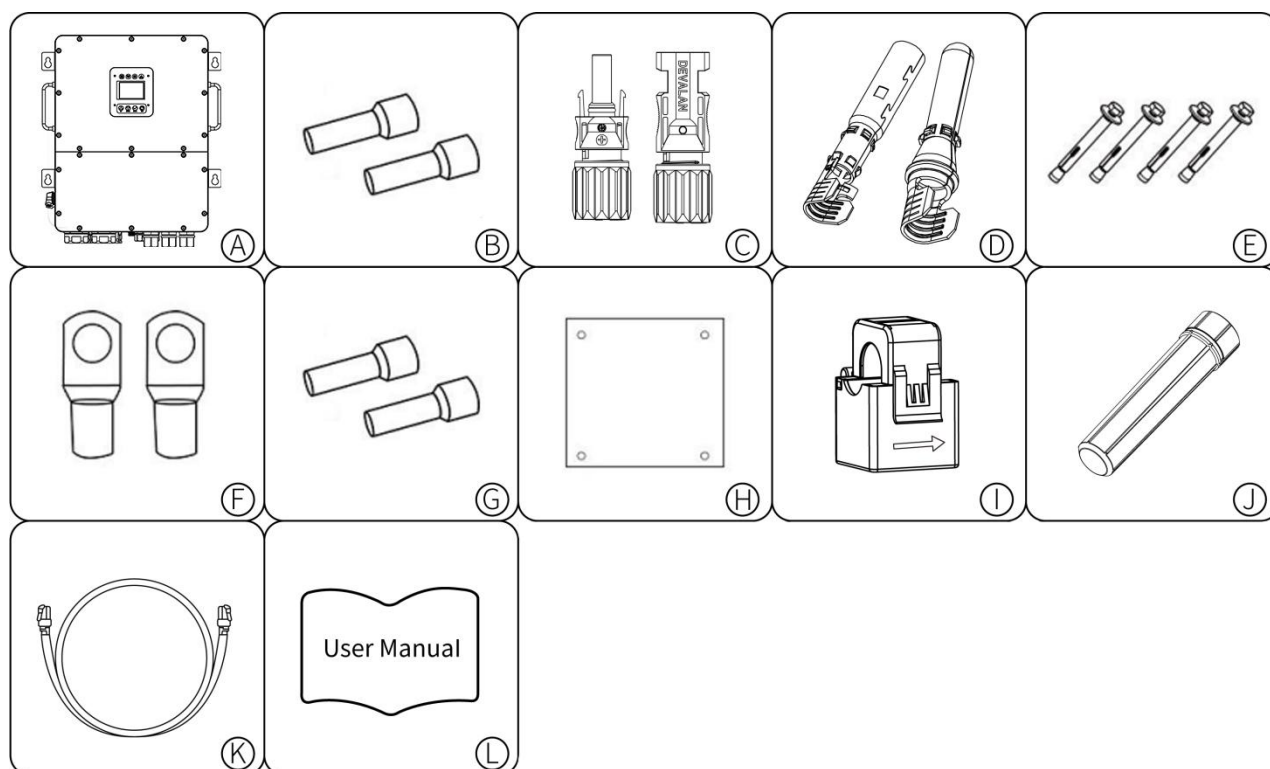

Item	Quantity	Description	Item	Quantity	Description
A	1	Inverter	B	10	Tubular Terminal (0.5 mm ²)
C	12	PV connectors (Black) (6*positive, 6*negative)	D	12	PV pin contacts (Black) (6*positive, 6*negative)
E	4	Parallel steel anti-collision bolt M12x60	F	4	Copper Terminal(50mm ²)
G	10	Tubular Terminal(16mm ²)	H	1	Positioning Board
I	1	CT (1000/1)	J	1	Wi-Fi module
K	1	Parallel communication cable	L	1	User manual

4.3 Storage

If the equipment is not to be installed or used immediately, please ensure that the storage environment meets the following requirements:

1. Do not unpack the outer package or throw the desiccant away.
2. Store the equipment in a clean place. Make sure the temperature and humidity are appropriate and there is no condensation.
3. The height and direction of the stacking inverters should follow the instructions on the packing box.
4. The inverters must be stacked with caution to prevent them from falling.
5. If the inverter has been stored for a long period of time, it should be checked by professionals before being put into use.
6. The storage temperature range is: $-25^{\circ}\text{C}\sim 60^{\circ}\text{C}$, and the storage humidity is $0\sim 95\%$.
7. The box must be suitable for loads of more than 30 kg.

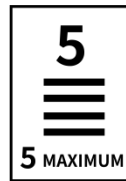
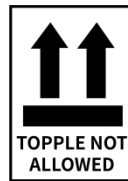

5. Installation

5.1 Installation Requirements

Installation Environment Requirements

1. Do not install the equipment in a place near flammable, explosive, or corrosive materials.
2. Do not install the equipment in a place that is easy to touch, especially within children's reach. High temperatures occur when the equipment is in operation. Do not touch the surface to avoid burning.
3. Avoid the water pipes and cables buried in the wall when drilling holes.
4. Install the equipment in a sheltered place to avoid direct sunlight, rain and snow. Build a sunshade if necessary.
5. The location of the equipment must be well-ventilated to prevent heat radiation and be large enough for operations.
6. The equipment with a high IP rating can be installed indoors or outdoors. The temperature and humidity at the installation site should be within the appropriate range.
7. Install the equipment at a height that is convenient for operation and maintenance, electrical connections, and checking indicators and labels.
8. The altitude to install the inverter shall be lower than the maximum working altitude 2000m or apply the derating power during the system dimensioning.
9. The PV modules used with the inverter must have an IEC61730 class A rating.
10. Overcurrent protection (such as a 250V AC/60A AC circuit breaker) must be provided before the AC input and after the EPS output. Ensure that the installation of those parts does not obstruct access to the disconnecting means.
11. Please ensure that there is adequate ventilation space for the inverter after installation, refer to the installation diagram below.
12. This inverter does not provide an internal isolated transformer between the PV input and battery with the AC output circuits. But basic isolation is provided between the PV input/battery/AC output circuits and the metal case/ground, and reinforced/double isolation is provided between the PV input/battery/AC output and the communication circuits (DRM/Meter/WiFi/RS485).
13. The PV input ranges and ratings please refer to the specification table of subclause 3.3.5, and please make sure that PV array should not be grounded.
14. Install the equipment away from electromagnetic interference. If there are radio stations or wireless communication equipment below 30 MHz near the installation location, please install the equipment as follows:
 - Add a multi-turn winding ferrite core at the DC input line or AC output line of the inverter or add a low-pass EMI filter.
 - The distance between the inverter and the wireless EMI equipment is more than 30m.

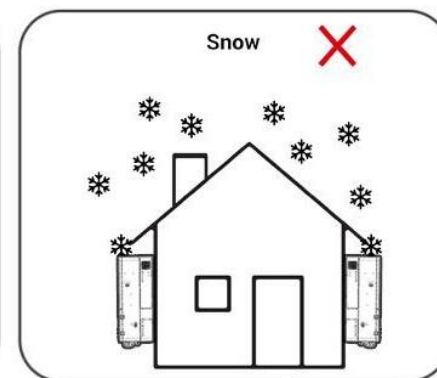
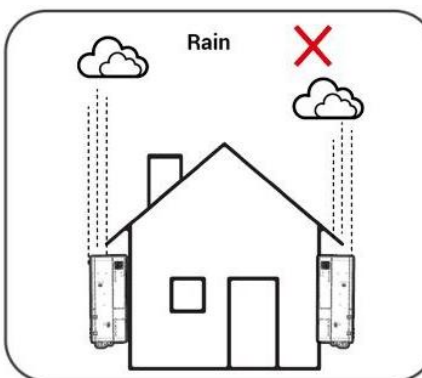
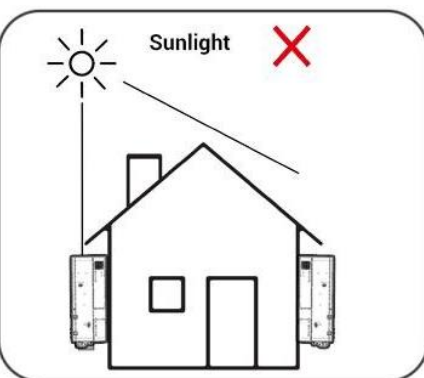
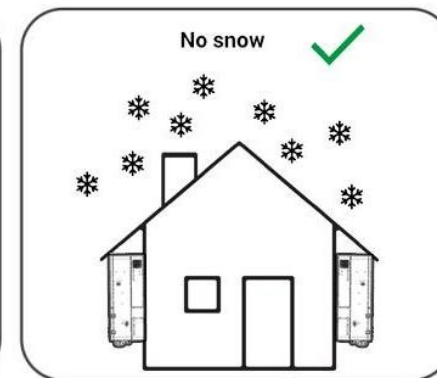
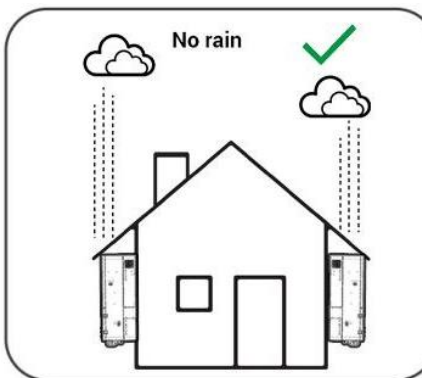
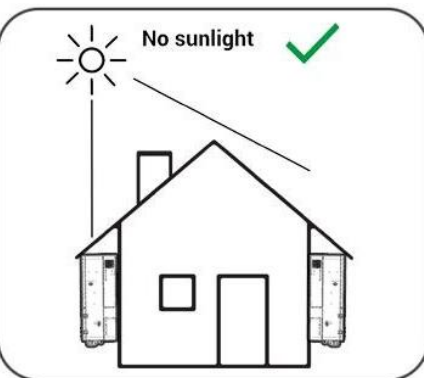
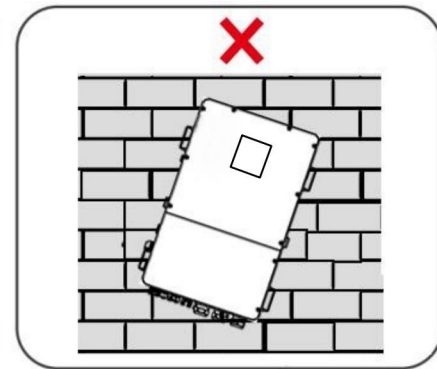
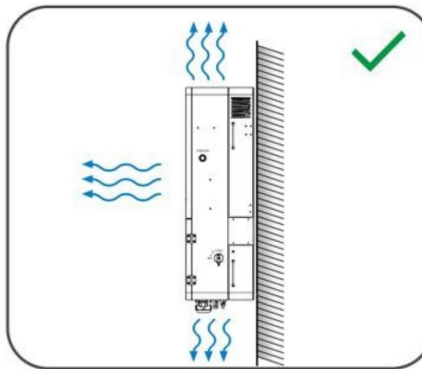
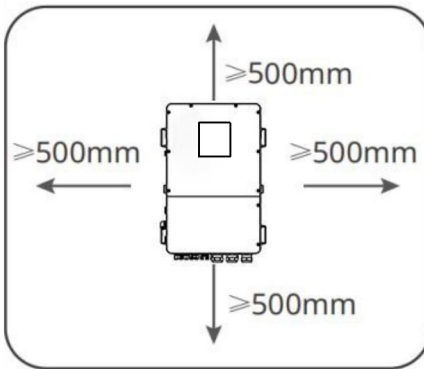
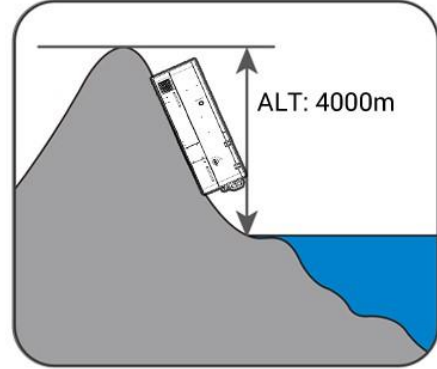
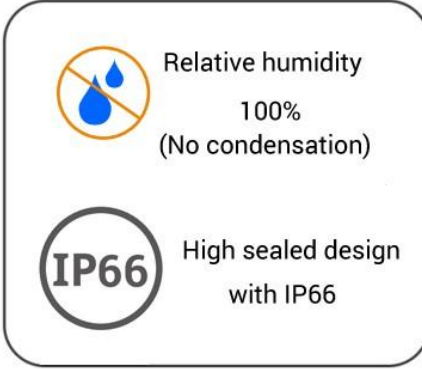
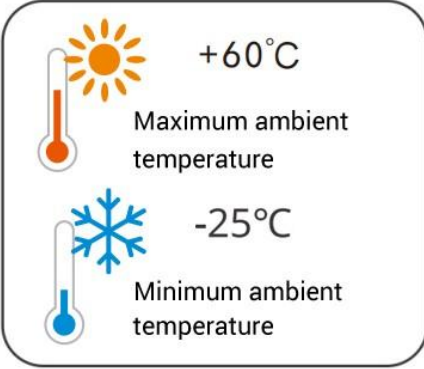
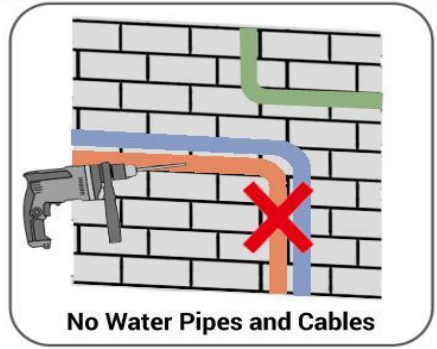

Installation Angle Requirements

- Install the inverter vertically or at a maximum back tilt of 15 degrees.
- Do not install the inverter upside down, forward tilt, back forward tilt or horizontally.

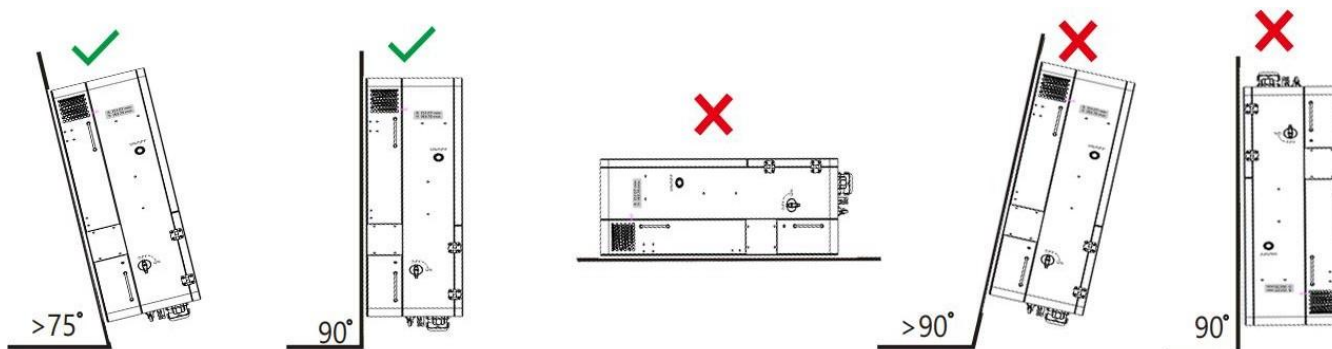

Installation Tool Requirements

The following tools are recommended when installing the equipment. Use other auxiliary tools on site if necessary.



5.2 Inverter Installation

5.2.1 Moving the Inverter

 CAUTION

- The unit is heavy. Do not lift it alone. During lifting procedures, ensure that the unit is securely supported to prevent the risk of accidental tipping or falling. Parts used to support or immobilize the unit must be designed and constructed to minimize the risk of physical injury and accidental loosening of fasteners. Ensure that the lifting method does not allow the unit to slip from chains and slings or tip or slide from lifting devices.
- Transportation must be carried by specialized personal (truck operators. Hook-up personal), equipped with the necessary protection equipment (overalls, safe shoes, protective gloves, helmets, goggles)
- Do not walk or stand beneath or in the proximity of the load. Avoid sudden movements and jolts when unloading and positioning the unit, Internal handling procedures must be conducted with care.
- Do not exert leverage on the components of the machine. If the unit is not balanced apply ballast, any protruding parts should not be supported by hand. The inverter must be installed so that the control panel is easily accessible and allows easy access to the power connection point.
- Accessible for maintenance and repair work. Parts for support or immobilization of unit shall be designed and manufactured to minimize the risk of physical injuries and accidental loosening of fixings.
- Loading capacity and hardness of the supporting surface, load rating of mounting bracket should be at least four times the weight of the devices according to IEC62109-1. And supporting characteristics will be impaired by wear, corrosion, material fatigue or ageing. This should be calculated by inspection of the design data of supporting material and consulting construction engineer.

5.2.2 Installation steps

 NOTICE

- Avoid the water pipes and cables buried in the wall when drilling holes.
- Wear goggles and a dust mask to prevent the dust from being inhaled or contacting eyes when drilling holes.
- Make sure the inverter is installed firmly to prevent it from falling.

Step 1 : Place the mounting plate or bracket on the wall horizontally and mark the positions for drilling the holes.

Step 2 : Drill holes to a depth of 80 mm using a hammer drill. The drill bit diameter should be 10 mm.

Step 3 : Secure the mounting plate using the expansion bolts.

Step 4 : Install the inverter on the mounting plate.

Step 5: Make sure the pin hook the inverter

Step 6 : Install the screws to lock it tight.

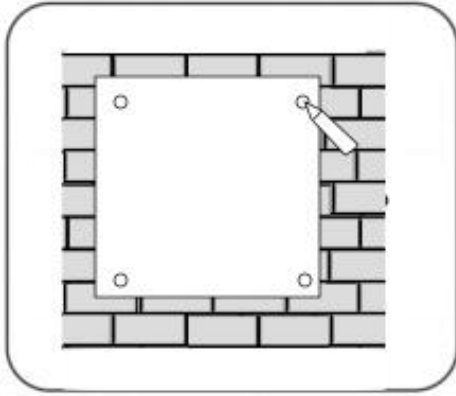

Step 1

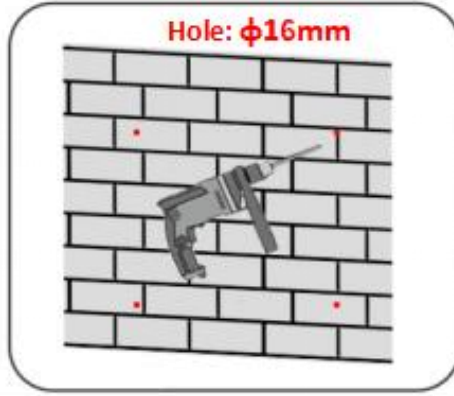

Step 2

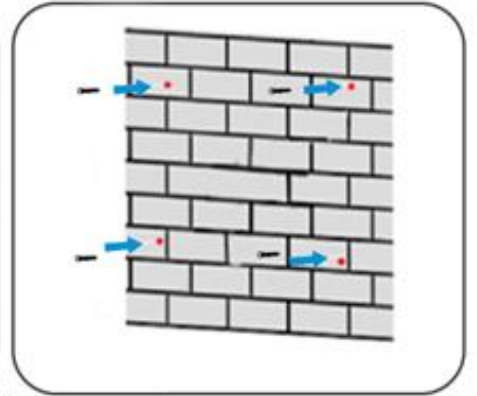

Step 3

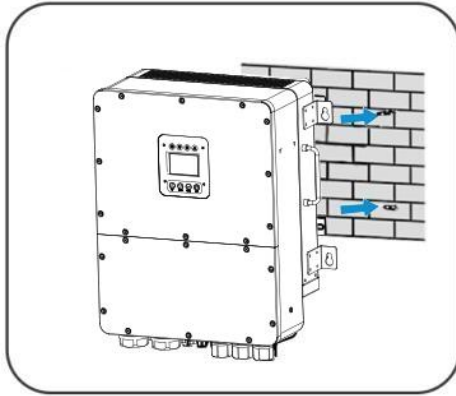

Step 4

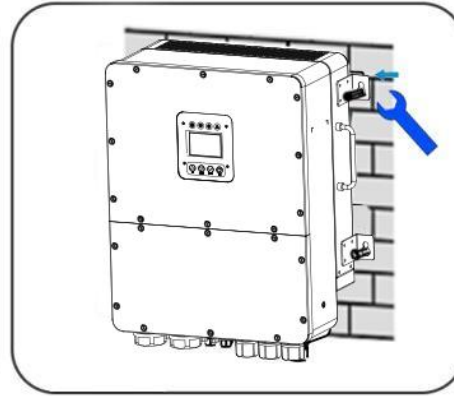

Step 5

6. Electrical Connection

6.1 Safety Precaution



- All operations, cables, and parts specifications during electrical connections must comply with local laws and regulations.
- To safely power off the inverter, disconnect both the DC switch and the AC output switch. Allow at least 5 minutes for the capacitor to discharge before making any electrical connections. Never work with the power turned on, as this may cause an electric shock.
- Group similar types of cables together and keep them separate from different types. Avoid placing the cables in an entangled or crossed manner.
- If the cable is under excessive tension, the connection may be poor. Leave a certain length of the cable before connecting it to the inverter cable port.
- When crimping the terminals, make sure the conductor part of the cable is fully in contact with the terminals. Avoid crimping the cable jacket along with the terminal. If this is not done correctly, the inverter may not operate, or the terminal block could be damaged due to overheating and other issues resulting from an unreliable connection during operation.







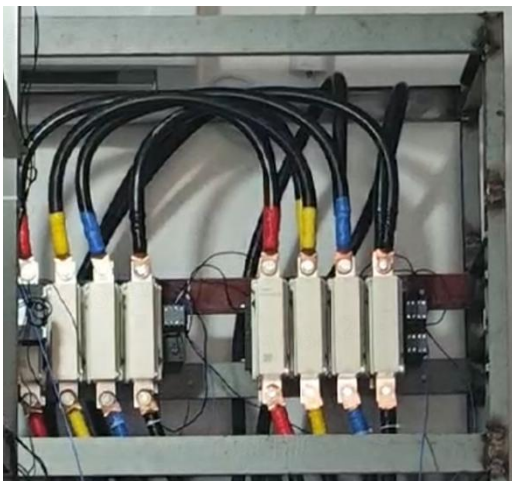

- Always wear personal protective equipment, including safety shoes, safety gloves, and insulating gloves, when making electrical connections.
- All electrical connections should be performed by qualified professionals.
- Cable colors in this document are for reference only. The cable specifications shall meet local laws and regulations.

6.2 Parallel connection notice

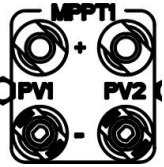
If Parallel quantity equal to 4 or bigger than 4, need add a parallel cabinet like follow, for detail can ask sales person.



6.3 Connection Port Description

Connector	Description	Recommend cable type	Recommended Cable specifications	
	+ : Connect the positive electrode of photovoltaic modules	Industry common outdoor Photovoltaic cable	Conductor cross-sectional area: 12 – 10 AWG	
	- : Connect the negative electrode of photovoltaic modules			
	+ : Connect the positive electrode of battery	Outdoor multi-core copper cable	Conductor cross-sectional area: 2/0 – 4/0 AWG	
	- : Connect the negative electrode of battery			
	EPS (Load)	L	Outdoor multi-core copper cable	Conductor cross-sectional area: 6 – 4 AWG
N				
PE				
	Grid (AC)	L	Outdoor multi-core copper cable	Conductor cross-sectional area: 6 – 4 AWG
N				
PE				
	GEN (AC)	L	Outdoor multi-core copper cable	Conductor cross-sectional area: 6 – 4 AWG
N				
PE				
	WiFi			

6.4 Connection Requirements

6.4.1 AC / DC Connection Requirements

Port	Terminal / Breaker Rating	Terminal Wire Size Range (min-max)
GRID	63A AC(10-12kW) 100A AC(14-16kW)	6 – 4 AWG
LOAD	63A AC(10-12kW) 100A AC(14-16kW)	6 – 4 AWG
GEN	63A AC10-12kW) 100A AC(14-16kW)	6 – 4 AWG
MPPT	32A DC	12 – 10 AWG
Battery Port	250A DC	2/0 – 4/0 AWG

6.4.2 Sensors and Communications Requirements

Component	Wire Size Range	Max Distance
CT Sensor	16-20 AWG	0' – 13' [4 m]: 16 AWG included 13' – 20' [6 m]: CAT6 extendable
Communications	24 – 23 AWG	0' – 100' [30 m]: 24 AWG 100' – 400' [120 m]: 23 AWG
RJ45 Parallel Communication	CAT 5E or better	0' – 7' [2.1 m]: Included 7' – 20' [6m]: Extendable

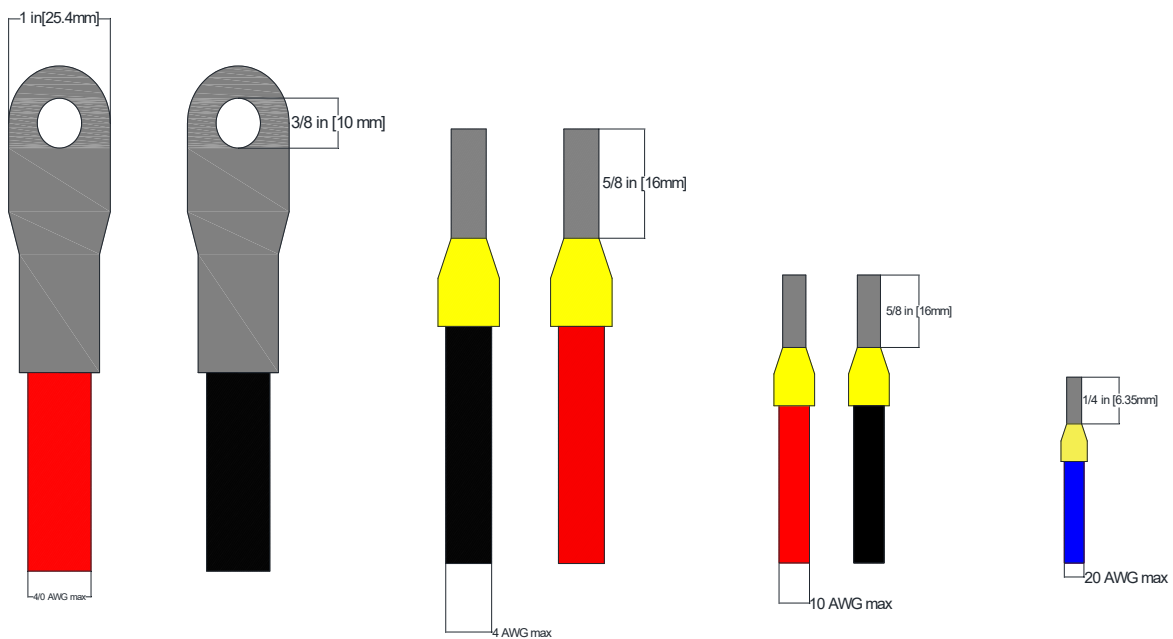

CT Sensors (Included)

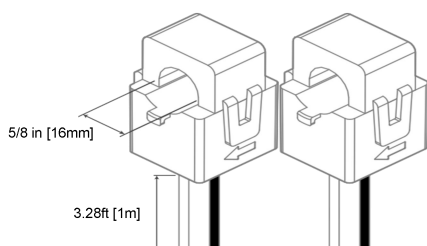

6.5 PE Cable Connection

⚠ WARNING

- The PE cable connected to the inverter's enclosure cannot replace the PE cable connected to the AC output port. Both PE cables must be securely connected.
- Ensure all grounding points on the enclosures are equipotentially connected when using multiple inverters.
- To enhance the corrosion resistance of the ground terminal, it is advisable to apply silica gel or paint after installing the PE cable.
- Prepare PE cables with the recommended specifications:
 - Type: Outdoor single-core copper wire.
 - Cross-sectional area: 10mm² (6AWG).

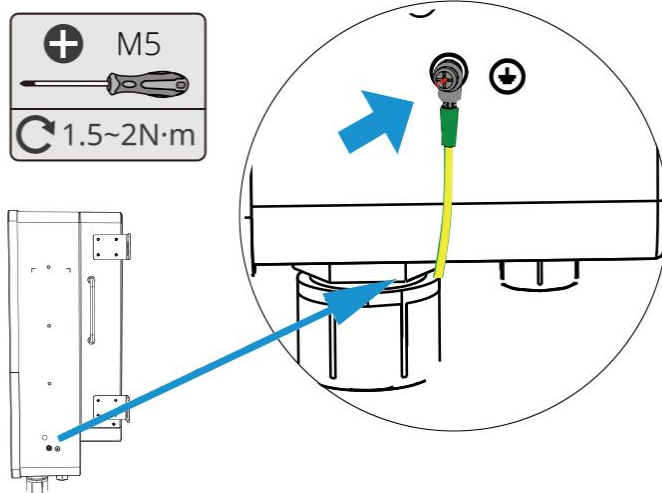
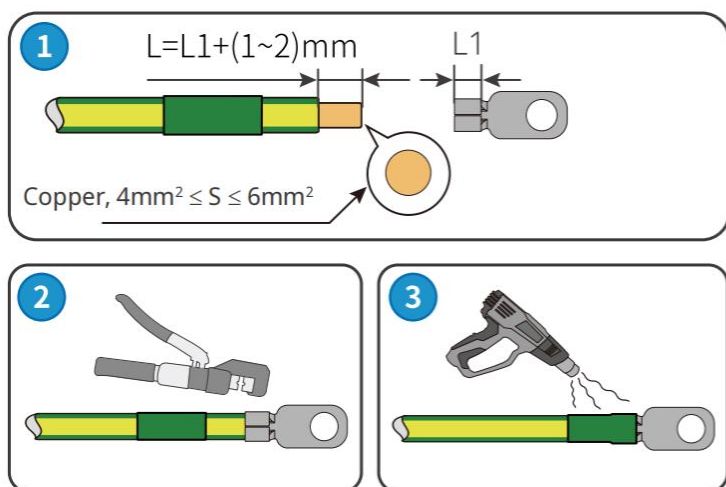

6.6 EPS, Grid and Generator Connection

NOTICE

SSE-HL10-16K-P1EU-S series inverters are designed for single-phase grids. The voltage range is 220/230/240V, and the frequency is 50/60Hz. Other technical specifications must comply with the requirements of the local public grid.

WARNING

- An AC breaker for maximum output overcurrent protection device must be installed between the inverter and the grid. The current rating of the protection device should refer to the table above, and no load should be connected directly to the inverter.

NOTICE

Check the grid voltage and ensure it falls within the permitted voltage range (refer to technical datasheet).

- Disconnect the circuit breaker from all the phases and secure against re-connection.

-

Wiring(as shown in picture)

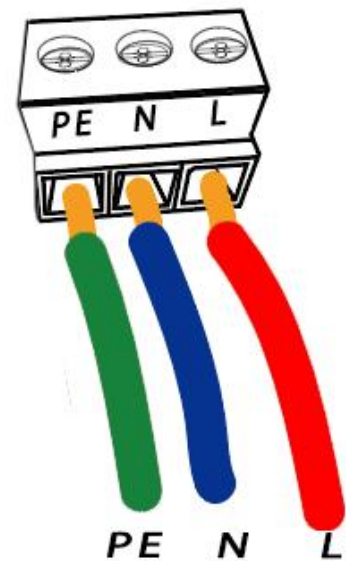
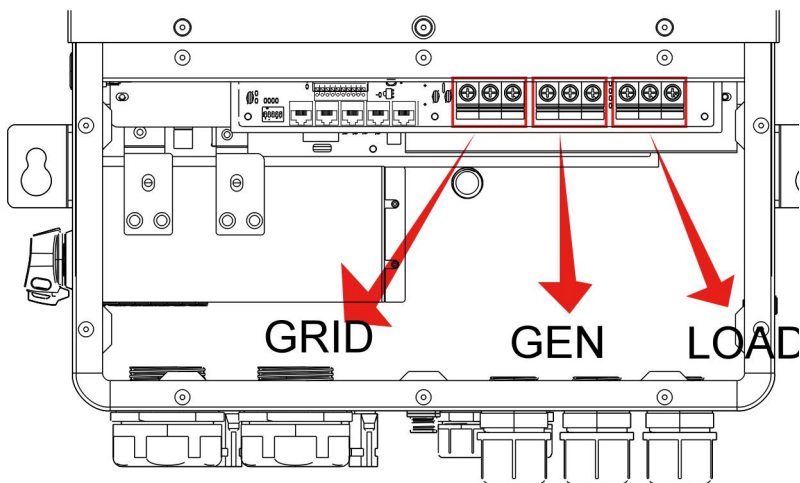

6.7 PV Connection

6.7.1 PV String Connection



Confirm the following information before connecting the PV string to the inverter. Otherwise, the inverter may be damaged permanently or even cause fire and cause personal and property losses.

1. Make sure that the max. short circuit current and the max input voltage per MPPT are within the permissible range.
2. Make sure that the positive pole of the PV string connects to the PV+ of the inverter. And the negative pole of the PV string connects to the PV- of the inverter.



- 1- Please choose a suitable external DC switch if the inverter does not have a built-in DC switch.
- 2- PV module voltage is very high and within a dangerous voltage range, please comply with the electric safety rules when connecting.
- 3- Please do not make PV positive or negative to ground.
- 4- PV modules: Please ensure that all components are of the same type, have identical output and specifications, are aligned properly, and are tilted at the same angle. To minimize cable use and reduce DC loss, we recommend installing the inverter as close to the PV modules as possible.



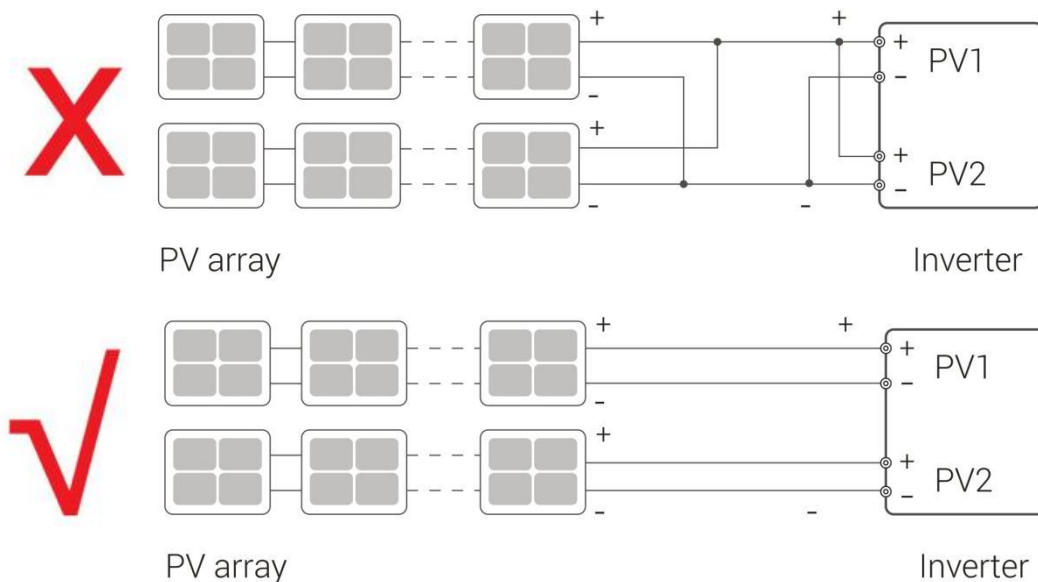

The DC input cable is prepared by the installer. Recommended specifications:

- Type: The outdoor photovoltaic cable must be compatible with the maximum input voltage of the inverter.
- Conductor cross-sectional area: 2.5~4mm² (Devalan) or 4~6mm² (MC4).

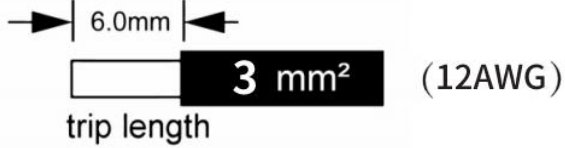
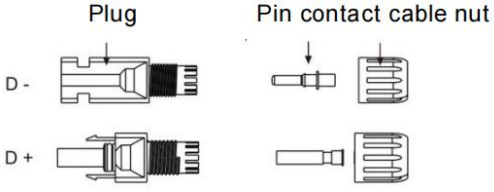
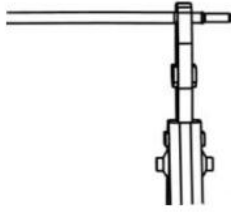

6.7.2 PV Wiring

<ul style="list-style-type: none"> • Turn off the PV and battery switch. • Choose 2,5-4mm² (12 AWG) wire to connect the PV module. • Trim 6mm of insulation from the wire end. 	 <p>6.0mm</p> <p>3 mm² (12AWG)</p> <p>trip length</p>
 <p>Plug</p> <p>Pin contact cable nut</p> <p>D -</p> <p>D +</p>	<p>Separate the DC connector (PV) as below.</p>
<ul style="list-style-type: none"> • Insert stripped cable into the pin contact and ensure all conductor strands are captured in the pin contact. • Put the pin contact with striped cable into the corresponding crimping pliers and crimp the contact. 	
	<p>Insert pin contact through the cable nut to assemble into the back of the male or female plug. When you feel or hear a “click” the pin contact assembly is seated correctly.</p>
<p>Unlock the DC connector</p> <ul style="list-style-type: none"> - Use the specified wrench tool. - When separating the PV + connector, push the tool down from the top. - When separating the PV - connector, push the tool down from the bottom. - Separate the connectors by hand. 	

6.8 Battery Connection



- The battery used with the inverter shall be approved by the inverter manufacturer. The approved battery list can be obtained through the official website.
- A short circuit in the battery may cause personal injury. The instantaneous high current caused by a short circuit can release a large amount of energy and may cause a fire.
- Before connecting the battery cable, ensure the inverter and the battery, and downstream and upstream switches are all disconnected.
- It is forbidden to connect and disconnect the battery cables when the inverter is running. Otherwise, it may cause electric shock.
- It is forbidden to connect loads between the inverter and batteries.
- When connecting battery cables, use insulated tools to prevent accidental electric shock or short circuits to the batteries.
- Ensure that the open circuit battery voltage is within the permissible range of the inverter.
- Install a DC switch between the inverter and the battery

WARNING

- Connect the battery cables to the corresponding terminals such BAT+, BAT- and grounding ports correctly. Otherwise, it will cause damage to the inverter.
- Ensure that the whole cable cores are inserted into the terminal holes. No part of the cable core can be exposed.
- Make sure the cables are securely connected. Otherwise, it may damage the inverter due to overheating during operation.
- Servicing of batteries should be performed or supervised by personnel knowledgeable about batteries and the required precautions.
- When replacing batteries, replace them with the same type and number of batteries or battery packs.
- CAUTION: Do not dispose of batteries in a fire. The batteries may explode.
- CAUTION: Do not open or damage batteries. Released electrolyte is harmful to the skin and eyes. It may be toxic.
- CAUTION: A battery can present a risk of electrical shock and high short-circuit current. The following precautions should be observed when working on batteries:
 - a) Remove watches, rings, or other metal objects.
 - b) Use tools with insulated handles.
 - c) Wear rubber gloves and boots.
 - d) Do not lay tools or metal parts on top of batteries.
 - e) Disconnect charging source prior to connecting or disconnecting battery terminals.
 - f) Determine if battery is inadvertently grounded. If inadvertently grounded, remove the source from ground. Contact with any part of a grounded battery can result in electrical shock. The likelihood of such shock can be reduced if such grounds are removed during installation and maintenance (applicable to equipment and remote battery supplies not having a grounded supply circuit).

Connection steps:

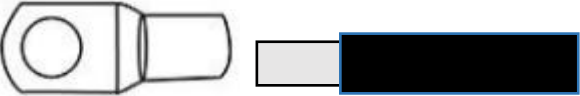
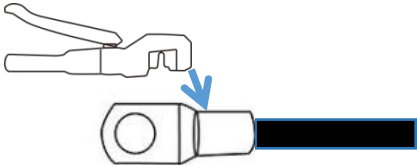
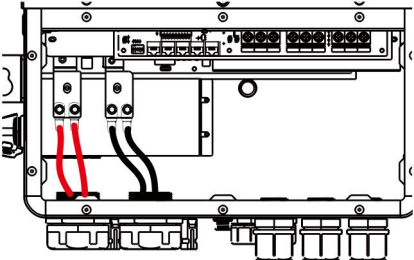
<ul style="list-style-type: none"> • Turn off the PV and battery switch . • Choose 2/0 – 4/0 AWG wire to connect the battery. • Trim 17mm of insulation from the wire end. 	
	<ul style="list-style-type: none"> • Make a copper terminal as shown in the picture.
<ul style="list-style-type: none"> • Insert the cable into the copper terminal port • Crimp pin contact by using a crimping plier. Put the pin contact with striped cable into the corresponding crimping pliers and crimp the contact. 	
	<ul style="list-style-type: none"> • Tighten the cables to the designated position inside the machine, as shown in the figure • The battery copper plate can connect three sets of batteries at the same time, 2*BAT(+) & 2*BAT(-)

6.9 Communication Cable Installation

NOTICE

The SSE-HL10-16K-P1EU series inverter are available with multiple communication options such as WiFi, Bluetooth, RS485 and Meter with an external device.

Operating information like output voltage, current, frequency, fault information, etc., can be monitored locally or remotely and cellphone App via these interfaces.

6.9.1 Communication Ports

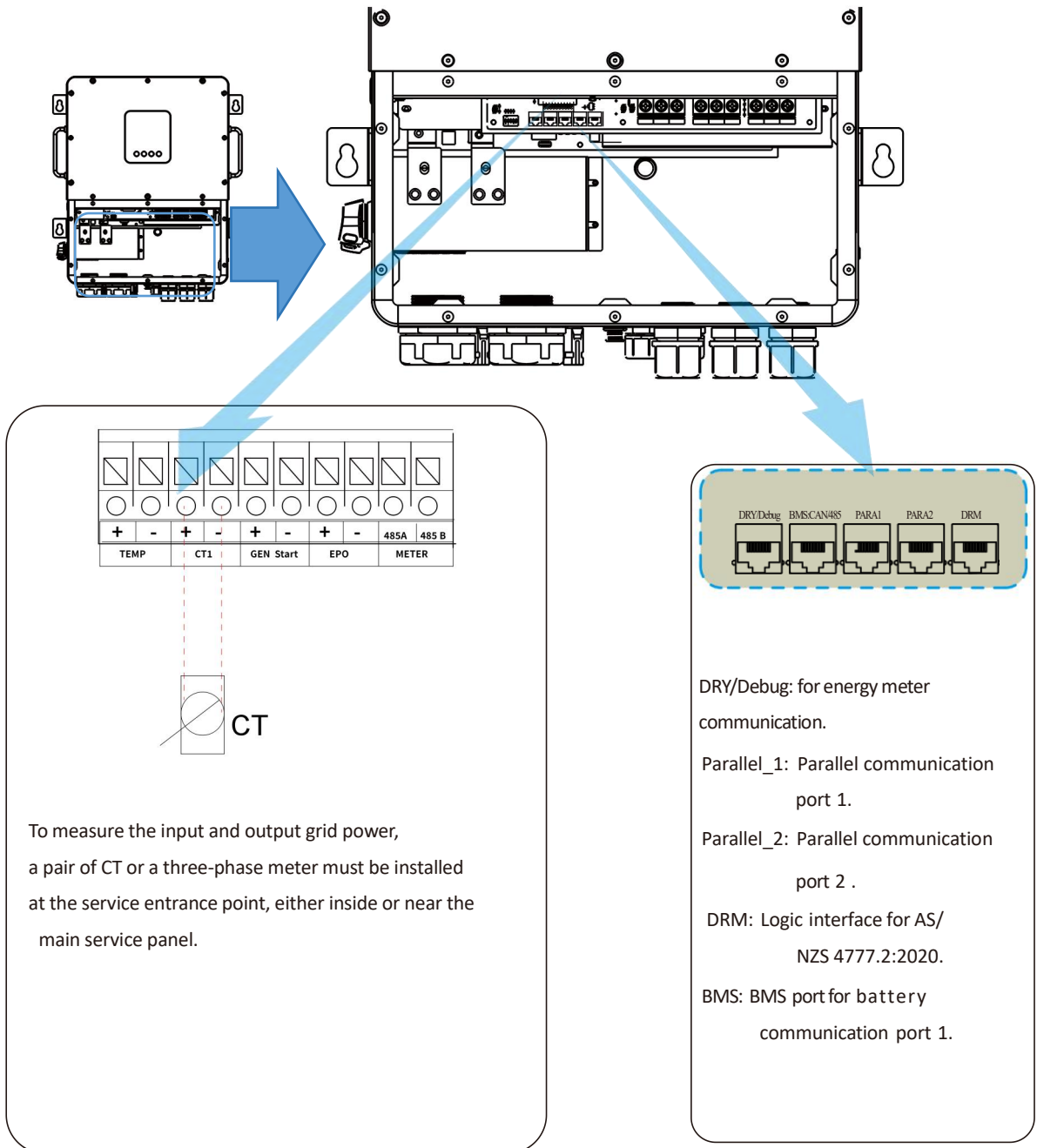

PIN	Meter	BMS RJ45	PARA1/2	DRM
1	Meter RS485A	Lead-acid cell NTC	Para Display CAN_H	DRM1/5
2	Meter RS485B	GND	Para Display CAN_L	DRM2/6
3	/	/	/	DRM3/7
4	5V_VCC	BMS_CAN1_H	Para Power CAN1_H	DRM4/8
5	FR_ALM_IN	BMS_CAN1_L	Para Power CAN1_L	REFGEN
6	5V_GND	GND	/	COM/DRM0
7	AFCI_485A	BMS_485A	Para Power CAN2_H	+12VS
8	AFCI_485B	BMS_485B	Para Power CAN2_L	GND

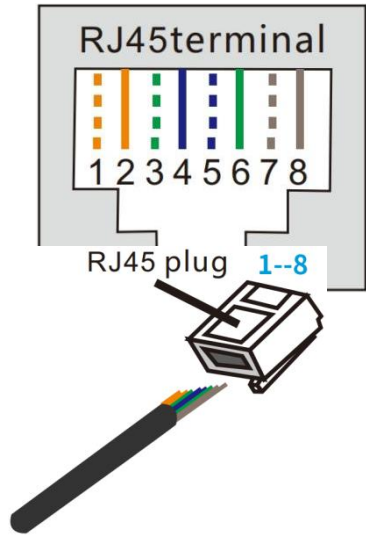

6.10 CT Connection (Default)

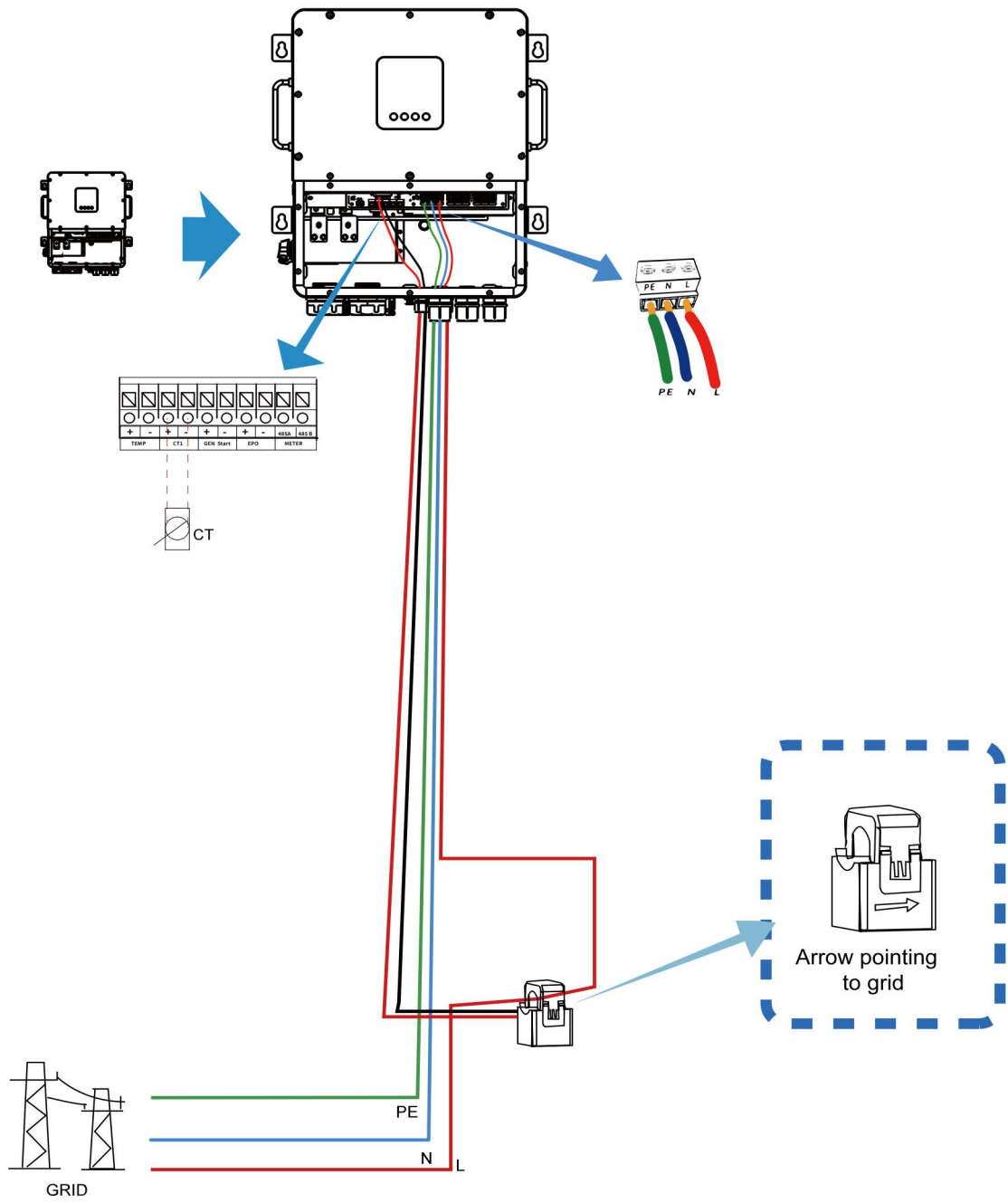

*Note: When the load power reading in the App is not correct, reverse the CT.

6.11 Single phase parallel connection system

— CAN
 — L wire
 — N wire
 — PE wire

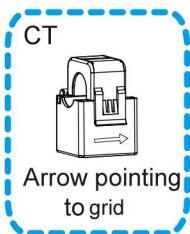
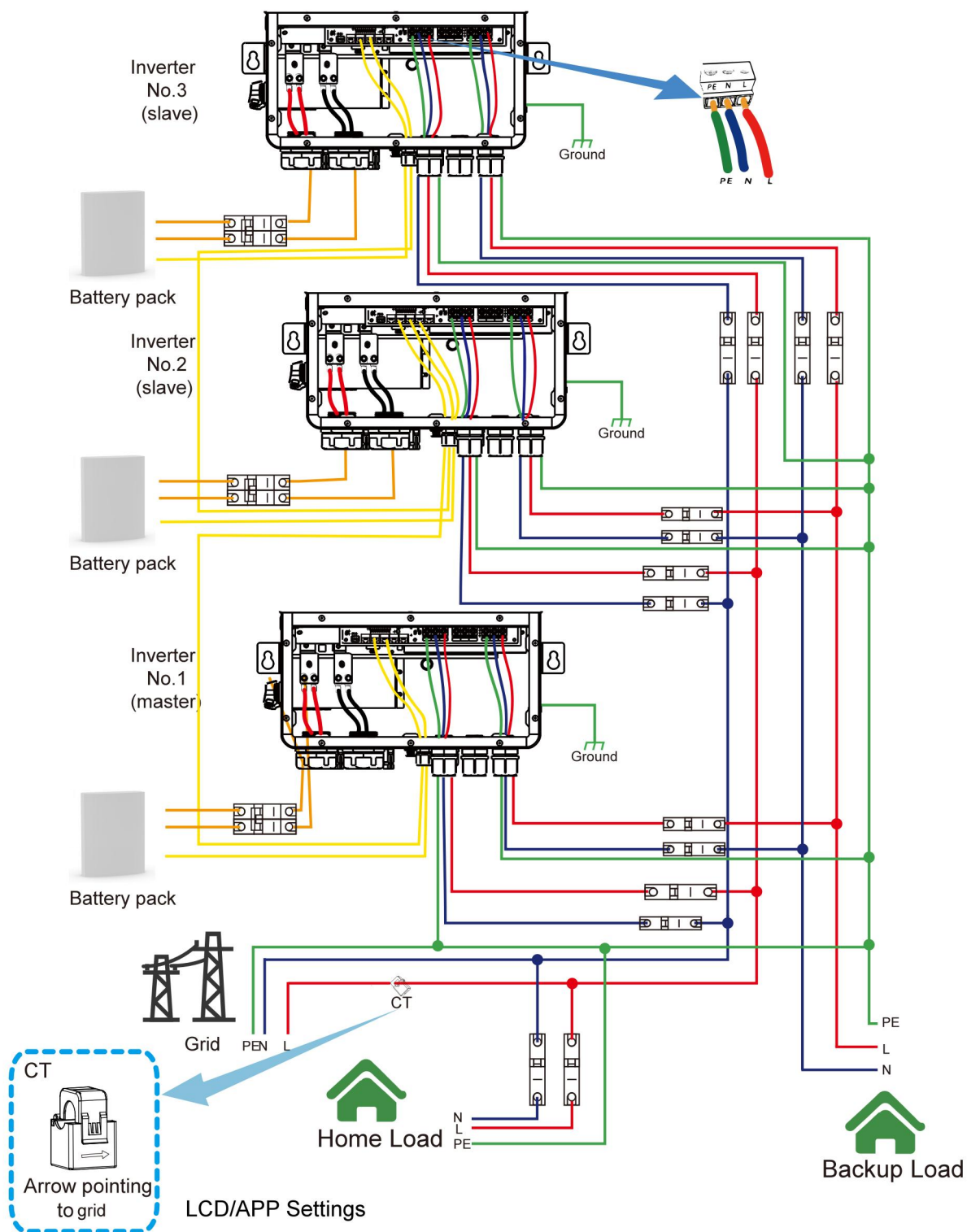

LCD/APP Settings

Master inverter	Slave Inverter	Slave Inverter
Parallel Setting	Parallel Setting	Parallel Setting
Parallel Type	Parallel Type	Parallel Type
Parallel Master	Parallel Slave	Parallel Slave
Parallel Number	Parallel Number	Parallel Number
3	3	3
Parallel Address	Parallel Address	Parallel Address
1	2	3

6.12 Wi-Fi&BLE stick installation and trouble shooting

6.12.1 Indication

- A: Circular Connector Interface: Connect to inverter and communication
- B: Red LED: Inverter communication indication
- C: Green LED: Network communication indication
- D: Product label: Show product information

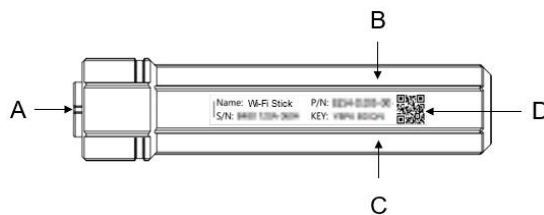

1. The LED lights up only when the Wi-Fi&BLE device is powered on.
2. When the Wi-Fi&BLE stick is powered on, the green LED glows for 3s as a power-on indication.
3. For more details about LED indication, see Chapter 6.9.6 “LED Indication and Troubleshooting”.

6.12.2 Install the Wi-Fi&BLE stick

Follow the installation steps!

1. Remove the waterproof cover.	2. Aligning groove.
3. Plug in WiFi module.	4. Rotate to lock the WiFi module.

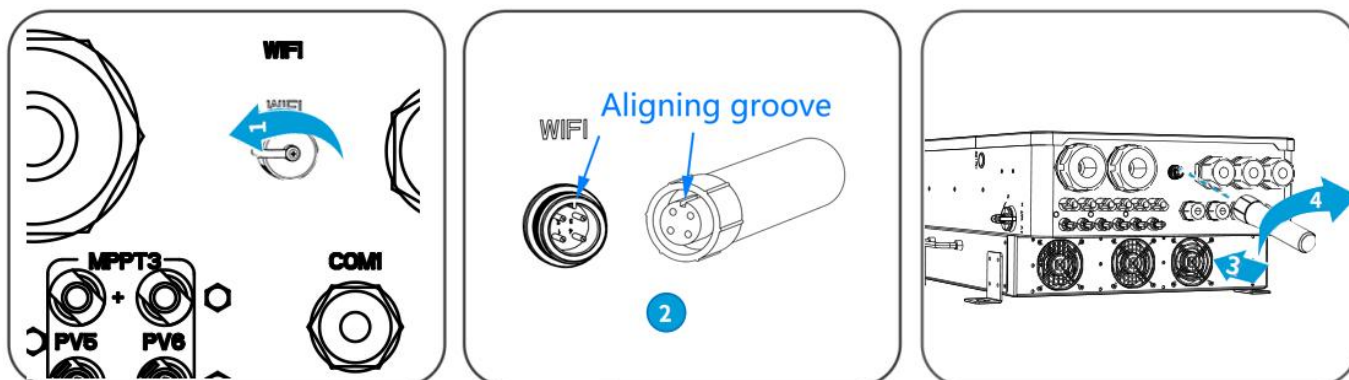

6.12.3 Web/APP

Item	Web View	APP	SOSEN Energy Web&APP manual
QR Code			
Website	https://sosen.inteless.com/	iOS: search “SOSEN Energy” in Apple Store Android: search “SOSEN Energy” in Google Play	https://www.soseninverter.com/product-manual.html

6.12.4 Wi-Fi Connection

The Wi-Fi connection diagram of the Wi-Fi&BLE device is shown in the following figure. The specific process can be done by downloading the APP and setting up the network connection according to the APP operation guide.



NOTICE











Wi-Fi Trouble Shooting

1. Place the inverter within 10 meters of the WiFi router.
2. Place the phone within 5 meters of the device's Bluetooth.
3. Make sure to enter the correct WiFi name and password.
4. The router must be set to 2.4GHz band.
5. Set the router's security mode to WPA2 or WPA, and it can not support WPA3.
6. Is the whitelist enabled on the router?

6.12.5 Installation qualification

If the Wi-Fi&BLE stick works normally, red LED and green LED are always glowing. Otherwise, it needs to be corrected by referring to chapter 6.9.6 "LED indication and trouble shooting"

6.12.6 LED indication and trouble shooting

LED	State	Indication
	Red LED: Inverter communication indication	
	Cycle for 2s: flash once quickly, then glowing	
	Not glow more than 20s	The power supply to the Wi-Fi&BLE stick is abnormal or damaged: 1. Check whether the power supply of the Aerial Plug Interface on the inverter is normal 2. Wi-Fi&BLE stick abnormal, contact the dealer
	Cycle for 2s: flash once quickly, then off	Communication failure: Check whether the connection between the Wi-Fi&BLE stick and inverter is loose or poor contact
	Green LED: Network communication indication	
	When powered on, continuously glows 3s, and then off	Power on indication
	Glow more than 5s	Communication is normal
	During the long glowing, flash occasionally	The network transmits data
	Cycle for 20s: flash once quickly, then off	The router is not connected: 1. Check whether the password is right 2. Check the strength of the router
	Cycle for 20s: flash 3 times continuously, then off	Connected to the route, but can't connect to the cloud server: 1. Check whether the router has Internet access permission 2. Check the firewall setting
	Cycle for 20s: flash 4 times continuously, then off	Wi-Fi&BLE stick information error: Please contact the dealer

7.Operation

7.1 Indicator panel

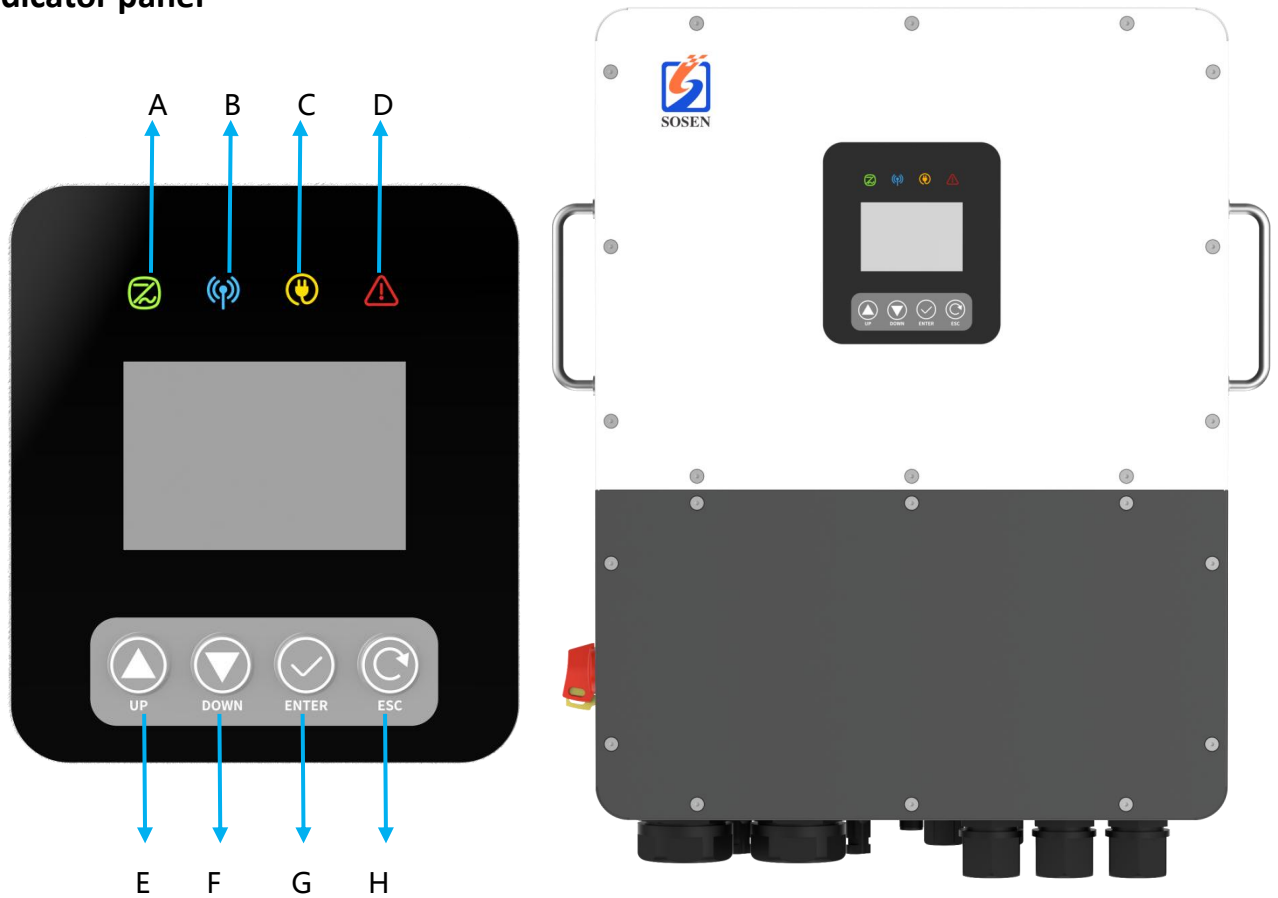

Name	Object	Function
Indicator LED	A	Green : ON, The inverter is running ; Flash is Standby.
	B	Blue : ON, Communication with BMS normal.
	C	Yellow : ON, The inverter is in EPS mode.
	D	Red : The inverter is in fault mode.
	E	UP:To go to previous selection
	F	DOWN:To go to next selection
	G	ENTER:To confirm the selection
	H	ESC:To exit setting mode

7.2 LCD operation flow chart

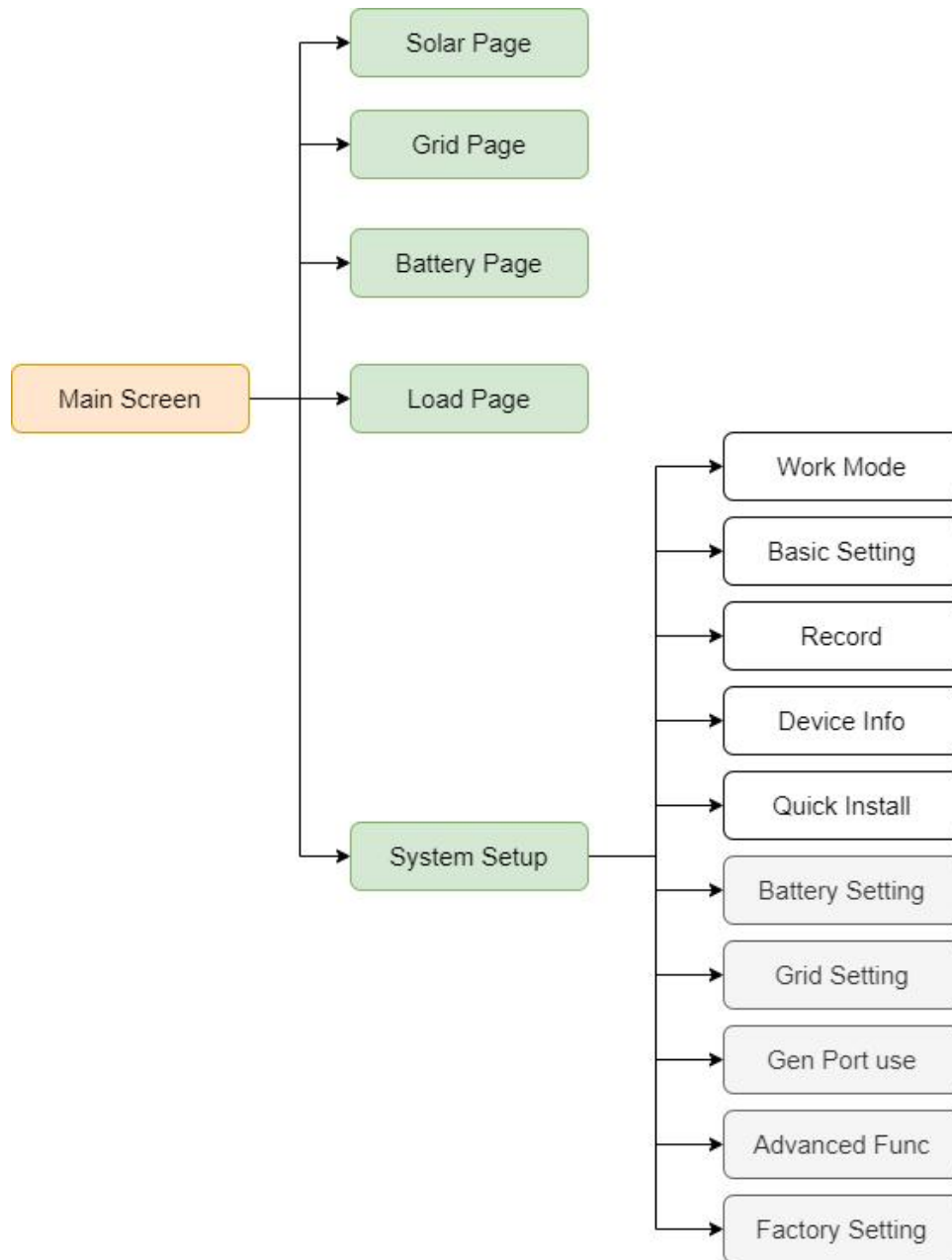

7.3 LCD Display Icons

7.3.1 Main Screen

The LCD is touchscreen,below screen shows the overall information of the inverter.

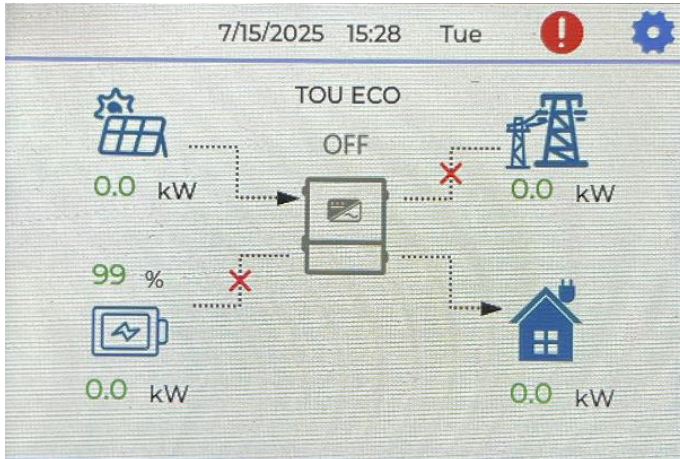

1.System Information Display

1.1 Date and Time

At the top of the screen displays the current system date and time.

1.2 Warning Icon ('!')

A red '!' mark indicates a system fault or abnormal condition.

Clicking the icon opens the fault detail page,where users can check the alarm messages and fault codes.

Follow the on-screen guidance or troubleshooting manual to resolve issues.

1.3 Settings Icon (Gear)

Click to access the system settings menu.

Includes configuration options such as operation mode,battery parameters,grid settings,etc.

2.Inverter Status and Operating Mode

2.1 Inverter Power Status

The icon in the center represents the inverter unit. Its power status is clearly shown as ON or OFF.

2.2 Current Operating Mode Display

The active system mode is shown above the inverter icon.

Possible modes include:TOU ECO,Self-Use,Backup,etc.

This helps users understand how the system is currently

3.Real-Time Energy Device Overview

The four blue icons visually represent the status and power of key energy components.Each icon is interactive:

3.1 Top Left--PV

Displays real-time solar generation power.

Click to view detailed PV status.

3.2 Top Right--Grid

Shows grid import power.

Click to view grid connection information.

3.3 Bottom Left--Battery

Displays current battery state of charge and charge/discharge power.

Click to view battery details.

3.4 Bottom Right--Load

Shows real-time load consumption.

Click to access detailed load information.

4.Energy Flow and Connection Indicators

4.1 Arrow Indicators

Arrows illustrate real-time energy flow paths.

The direction indicates the power flow direction (e.g.,from PV to Load).

4.2 Red"X"Icons

Indicate that a path or device is not connected or inactive.

Examples include:battery not installed,grid offline,etc.

-PV power and Load power always keep positive.

-Grid power negative means get from grid,positive means sell to grid.

-Battery power negative means charge,positive means discharge.

7.3.2 PV Information Page Overview



(Subject to variation depending on project configuration)

When the PV icon on the main interface is clicked, the system navigates to the PV information page. Here, PV1 to PV4 display the voltage, current, and power data for each of the four PV input channels. Below these readings, users can view the total current PV power, the energy generated today, and the historical cumulative generation. Page navigation arrows on the side of the screen allow users to scroll through additional PV data pages

7.3.3 Grid Information Page Overview

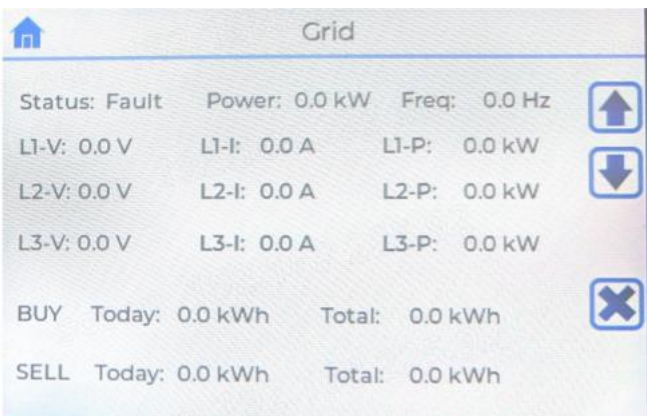

The Status field indicates the operating condition of the inverter; in this example, the current status is "Fault."

The Power field displays the total grid power.

Freq refers to the present grid frequency.

L1, L2, and L3 represent the three AC phases (R, S, T), each showing their respective voltage, current, and power values.

At the bottom of the page, the energy purchased from the grid is displayed, including both the daily purchased energy and cumulative purchased energy. (Note: These fields may vary depending on the specific project configuration.)

7.3.4 Battery Information Page Overview

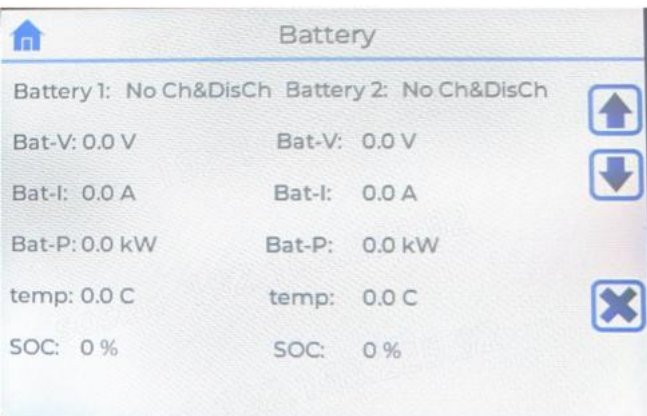

This page displays the operating information of Battery 1 and Battery 2 (subject to variation depending on the project configuration).

Key parameters include the current battery status, voltage, current, power, temperature, and State of Charge (SOC).

7.3.5 Load Information Page Overview

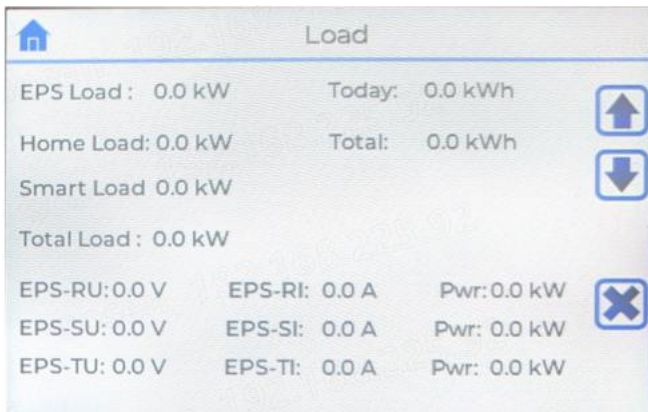

(Subject to variation depending on the project configuration)

This page includes readings for EPS load power, household load power, smart load power, and the total load power.

Below these values, the page also displays the voltage, current, and power for the three AC phases: R, S, and T (corresponding to L1, L2, and L3).

7.4 System Setup Menu

System Settings Page (Standard User Access)

This is the settings page available under standard user permissions.

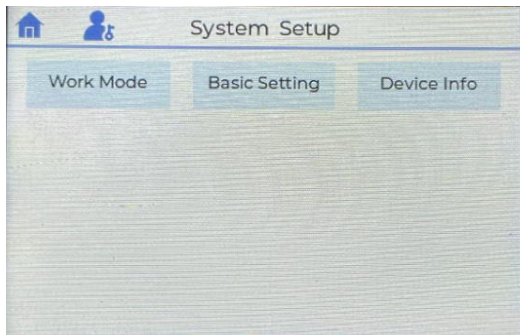

To enter basic settings mode, click the icon  in the upper-left corner and enter the password **0000**.

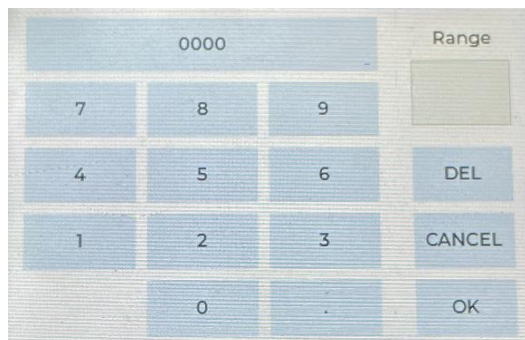

Advanced User Access

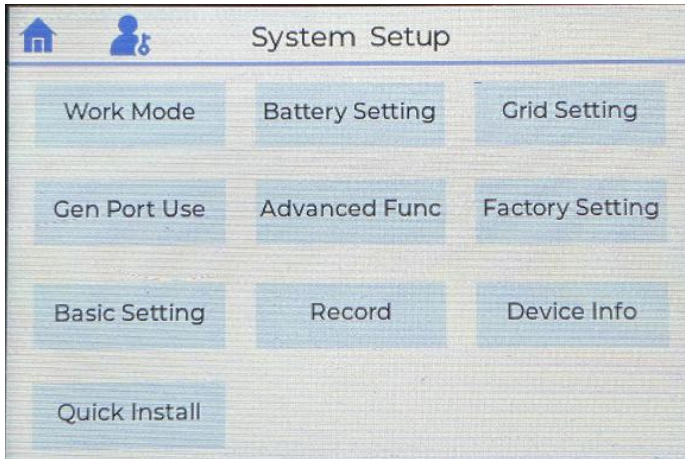

To enter advanced settings mode, click the icon  in the upper-left corner and enter the password 7777. Once verified, the system will open the Advanced Settings Page, where users can access additional configuration options not available under standard permissions.

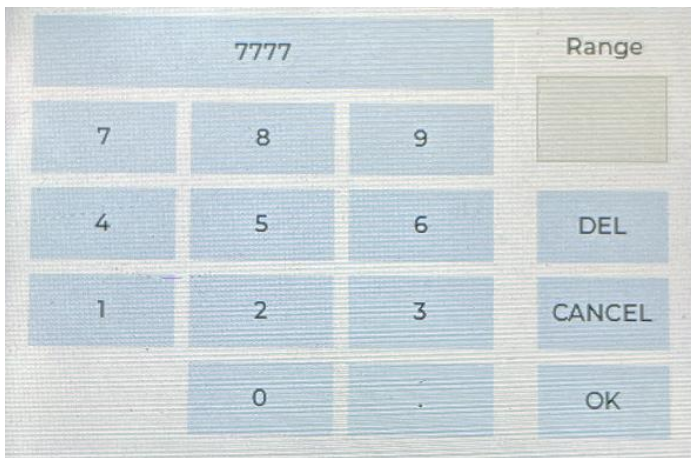

7.5 Basic Settings Menu

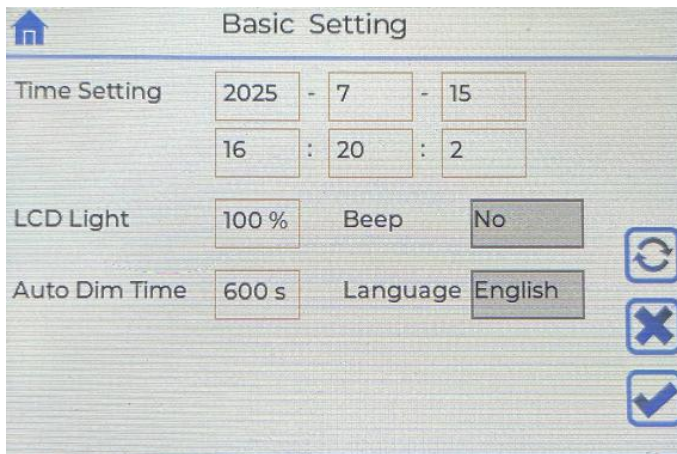

-Time Setting:

Set the system's date and time, including year, month, day, hour, and minute.

-LCD Light:

Adjust the screen brightness level.

-Beep:

Enable or disable the buzzer.

Enabled by default; the buzzer will sound upon touch or key press.

-Auto Dim Time:

Set the duration before the screen automatically dims or turns off.

-Language:

Select the system display language.

7.6 Work Mode Settings Menu

Work Mode Settings-Page 1

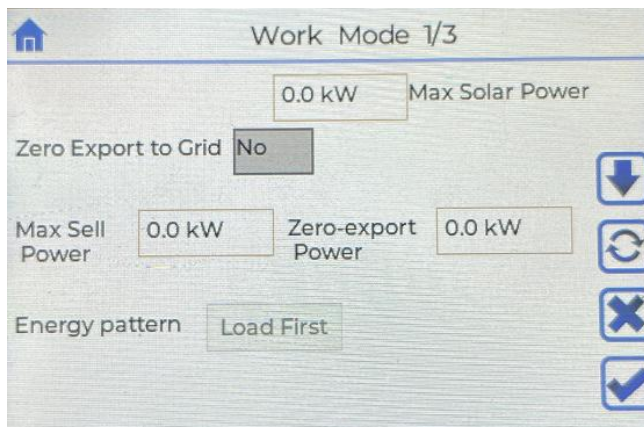

-Max Solar Power:

Sets the maximum PV input power.

Zero Export to Grid:

When enabled, the inverter limits the amount of power exported to the grid.

The actual export limit is defined by the Zero-export Power setting.

-Zero-export Power:

Specifies the inverter's export power limit to the grid.

This setting takes effect only when Zero Export to Grid is enabled.

-Max Sell Power:

Sets the maximum power that can be exported to the grid.

-Energy Pattern:

Defines the system's energy priority strategy. Currently, only **Load First** mode is supported.

-Load First:

PV power is used first to supply the load.

Any surplus PV energy is then used to charge the battery. If PV is insufficient, the grid will supply the load.

Work Mode Settings-Page 2

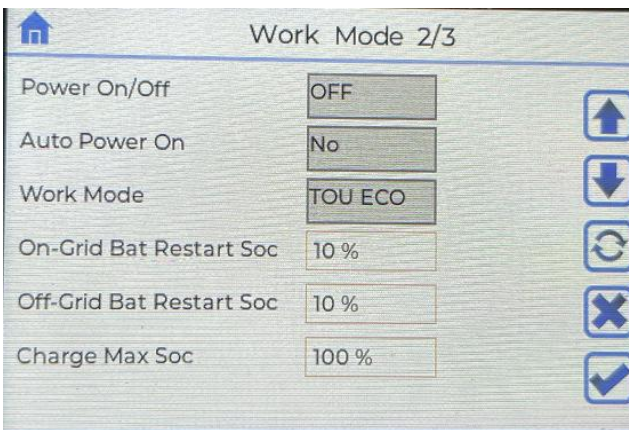
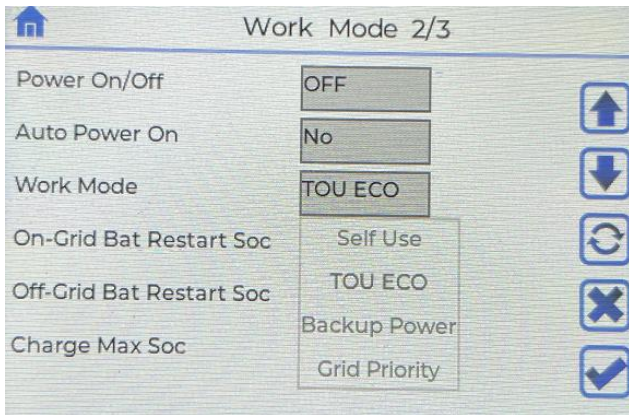

-Power On/Off:

Manually switches the inverter ON or OFF.

-Auto Power On:

Enables automatic startup and shutdown.

When enabled, the inverter will power on automatically.

-Work Mode:

Sets the system's working mode. Available options include:

Self-USE, TOU ECO, Backup Power, and Grid Priority.

-On-Grid Bat Restart SOC:

When the inverter is connected to the grid:

Battery is allowed to discharge if SOC 10%.

If battery SOC drops below (Restart SOC-3), the inverter will trigger forced charging to

raise SOC back to 10%.

-Off-Grid Bat Restart SOC:

When the inverter is off-grid (not connected to the utility):

Battery is allowed to discharge if SOC 10%.

-Charge Max SOC:

Sets the maximum battery SOC for charging.

Once this limit is reached, charging will stop automatically.

Work Mode Settings-Page 3(TOU Mode Settings)

	Time	Type	Curr	SOC
-	00:00 12:30	Disch	50 A	20 %
-	12:30 16:30	Self Use	50 A	40 %
+	16:30 23:59	Disch	30 A	90 %

To enable TOU scheduling, the Work Mode on **Work Mode Settings – Page 2** must be set to **TOU ECO**. Only then will the time-based configuration become effective.

-Time:Defines the time slots used for energy management.

The full 24-hour day must be divided into continuous,non-overlapping periods.Each time slot includes a start time and an end time.Up to 6 time slots can be added by clicking the "+"icon.

-Type:Defines the behavior of the system during the time slot:

Discharge:Battery discharges according to the specified parameters.

Charge:Battery charges using PV or grid power.

Self-Use:Prioritizes self-consumption from PV.

-Curr:Sets the maximum charging or discharging current for the battery.

-SoC:Target SOC value for the battery during the time slot.

Example Schedule:

Time Period	Priority Type	Zero Export Disabled	Zero Export Enabled
00:00 – 12:30	Discharge	- Battery discharges if SOC > 20% (up to 50A limit) - Excess PV is exported to the grid	- Same discharge behavior - Excess PV charges battery to avoid waste
12:30 – 16:30	Self Use	- Battery discharges if SOC > 40% when PV cannot meet load - Battery charges if SOC < 36% using PV or grid - Remaining PV is exported	- Same behavior - No export allowed: Excess PV not used for load or charging is curtailed
16:30 – 23:59	Charge	- Battery charges if SOC < 90% using PV + grid (up to 30A) - Excess PV is exported	- Same charging behavior - No export allowed: Any excess PV after charging is curtailed

7.7 Battery Settings Menu

Battery1 Setting1 – Page 1

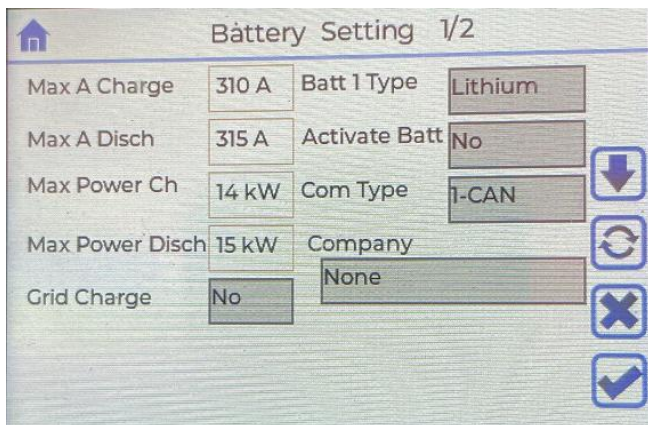

1.-Max A Charge / Max A Disch:
Set the **maximum battery charging current** and **maximum battery discharging current**, respectively.

-Max Power Ch / Max Power Disch:
Set the **maximum charging power** and **maximum discharging power** for the battery.

-Grid Charge:
Enables or disables battery charging from the utility grid.

2.-Parallel Bat & Bat2:
For inverter models with two battery ports, enabling this function allows a single battery to be connected to both **Battery Port 1** and **Battery Port 2** simultaneously.
In this case, the battery communication cable should be connected to the inverter’s **BMS1 port**.

-Batt1 Type:
Select the battery type. Available options include: **Lithium, Lead-acid, DC Source, and No Battery**.

-Activate Batt:
Manually triggers battery activation or wake-up.

3.-Com Type:
Select the battery communication protocol: **CAN** or **RS485**

-Company:
Select the battery manufacturer. The system will automatically match the correct communication protocol based on the selected brand.

Battery1 Setting2 – Page 2

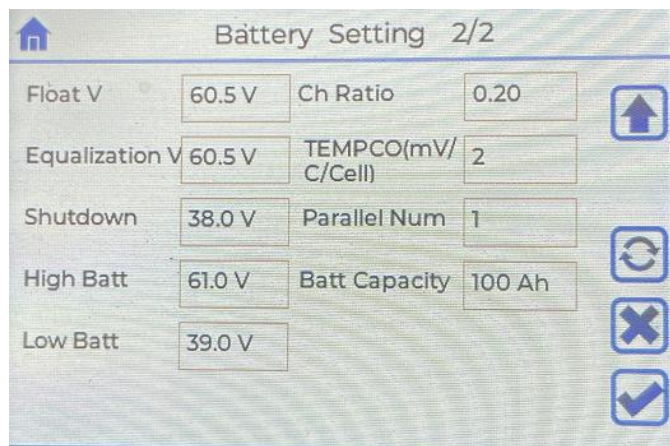

Float V:

Sets the **battery float charging voltage**.

Ch Ratio:

Sets the **charging C-rate** (charging ratio), applicable **only to lead-acid batteries**.

Equalization V:

Sets the **equalization charging voltage**.

TEMPCO:

Battery **temperature compensation coefficient**, applicable **only to lead-acid batteries**.

Shutdown:

Sets the **battery discharge cutoff voltage** for protection.

Parallel Num:

Sets the **number of parallel-connected battery groups**. This setting is required **only for lead-acid batteries** used in multiple parallel clusters.

High Batt / Low Batt:

Define the **battery port over-voltage** and **under-voltage protection thresholds**, respectively.

Batt Capacity:

Set the **battery capacity**, applicable **only to lead-acid batteries**.

Recommended battery settings

Battery Type	Absorption Stage	Float Stage	Equalization Voltage (every 30 days 3hr)
AGM(or PCC)	14.2V (57.6V)	13.4V (53.6V)	14.2V (57.6V)
Gel	14.1V (56.4V)	13.5V (54.0V)	
Wet	14.7V (59.0V)	13.7V (55.0V)	14.7V (59.0V)
Lithium	Follow its BMS voltage parameters		

7.8 Grid Settings Menu

Grid Settings – Page 1

The screenshot shows a 'Grid Code Selection 1/4' menu with the following settings:

Grid Mode	Italy CEIO-21	Grid Sensor	None
Grid Volt	220V	CT Ratio	0
Grid Freq	50Hz	Meter Addr	1
Zero Export	No	Meter Select	CHNT
Zero Export Power	0.0 kW	Max Buy Power	0.0 kW
Max Sell Power	0.0 kW		

Grid Mode: Select the national grid standard according to the installation region (e.g.,Italy-CEIO-21,Spain UNE217002).

Grid Sensor: Configuration of the grid-side current sampling method.Options include:

None:Inverter samples current internally at the grid port.

CT:External current transformer(CD)is used for sampling.

Meter:External smart meter connected via RS485 for grid data acquisition.

Grid Volt:Set the nominal grid voltage according to the country standard.

Grid Freq:Set the nominal grid frequency based on the local grid specification.

CT Ratio:Set the CT transformation ratio.

Zero Export:When enabled,the inverter will limit the power exported to the grid.

The limit is defined by the Zero-export Power setting.

Zero-export Power: Sets the maximum inverter export power.This is only effective when Zero Export is enabled.

Meter Addr: Set the RS485 address of the external energy meter.

Meter Select:Select the meter manufacturer.Please ensure the selected model matches the actual hardware.

Max Sell Power:Sets the maximum allowed output power exported to the grid.

Max Buy Power:Sets the maximum allowed input power drawn from the grid to the inverter

Grid Settings – Page 2

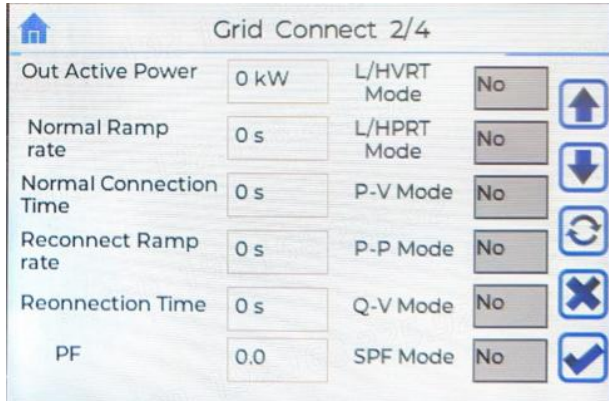

Parameter	Value	Mode	Setting	Icon
Out Active Power	0 kW	L/HVRT Mode	No	Up Arrow
Normal Ramp rate	0 s	L/HPRT Mode	No	Down Arrow
Normal Connection Time	0 s	P-V Mode	No	Refresh
Reconnect Ramp rate	0 s	P-P Mode	No	X
Reconnection Time	0 s	Q-V Mode	No	Checkmark
PF	0.0	SPF Mode	No	Checkmark

Reserved:This function is reserved.It is not recommended.Please inform the manufacturer/installer before setting up

Out Active Power:

Sets the maximum apparent power output to the grid.

Normal Ramp Rate:

Sets the power ramp-up time after inverter startup.

Normal Connection Time:

Sets the time delay before the inverter injects active power to the grid after startup.

Reconnect Ramp Rate:

Sets the ramp-up time for active power after fault recovery.

Reconnection Time:

Sets the reconnection delay time after a fault is cleared.

Grid Settings-Page 3

Grid Protection 3/4			
High volt 1	0.0 %	Low volt 1	0.0 %
High volt 2	0.0 %	Low volt 2	0.0 %
		Low volt 3	0.0 %
High volt time 1	0.00 s	Low volt time 1	0.00 s
High volt time 2	0.00 s	Low volt time 2	0.00 s
		Low volt time 3	0.00 s
High volt recv	0.0 %	Low volt recv	0.0 %

**Reserved:This function is reserved.It is not recommended.
Please inform the manufacturer/installer before setting up**

High Volt 1/High Volt 2:Level 1 and Level 2 overvoltage protection thresholds (as a percentage of nominal voltage).

High Volt Time 1/High Volt Time 2:Time delays for triggering Level 1 and Level 2 overvoltage protection.

High Volt Recv:Grid overvoltage recovery threshold.

Low Volt 1 Low Volt 2:Level1 and Level 2 undervoltage protection thresholds,also defined as percentages of the nominal voltage.

Example

To adjust the acceptable voltage range of the inverter for grid connection:

Simply configure High Volt 1 and Low Volt 1 values.

If the nominal voltage is 230V:

High Volt 1 at 120%-Overvoltage point 276V

Low Volt 1 at 80%-Undervoltage point 184V

If the nominal voltage is 220V:

High Volt 1 at 120%-Overvoltage point 264V

Low Volt 1 at 80%-Undervoltage point 176V

Grid Settings-Page 4

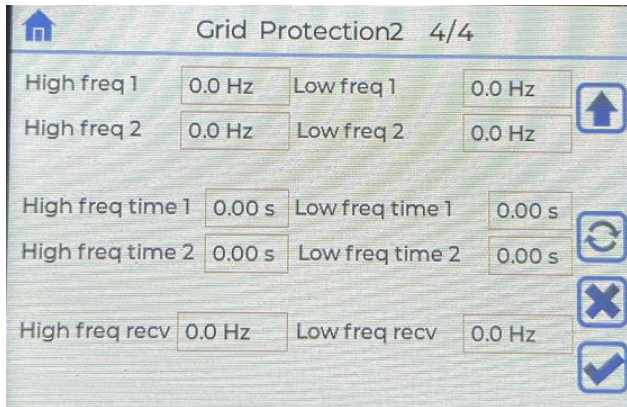

Reserved: This function is reserved. It is not recommended.

Please inform the manufacturer/installer before setting up

High Freq 1 and High Freq 2 refer to the first- and second-level over-frequency protection thresholds (in Hz). These values are typically based on the system's nominal frequency (e.g., 50Hz or 60Hz).

High Freq Time 1 and High Freq Time 2 define the delay time before triggering protection actions when the grid frequency exceeds the corresponding threshold.

High freq recv: The recovery point frequency value of the power grid overfrequency protection. When the frequency recovers from too high to below this value, the system will allow reconnection to the grid or resume operation.

Low Freq 1 and Low Freq 2 represent the first- and second-level under-frequency protection thresholds. If the frequency falls below these values, protection will be triggered accordingly.

Low Freq Time 1 and Low Freq Time 2 set the delay durations before activating under-frequency protection once the frequency drops below the set limits.

Low Freq Recv: The recovery threshold for under-frequency protection. The system will reconnect or resume operation when the grid frequency rises above this value.

Example:

If the system nominal frequency is 50Hz, and the settings are as follows:

High Freq 1 = 52Hz, Low Freq 1 = 47Hz

The system will trigger first-level protection when the frequency goes above 52Hz or below 47Hz, based on the defined time delays.

High Freq 2 = 53Hz, Low Freq 2 = 46Hz

More severe deviations will activate second-level protection mechanisms. High Freq 1 and High Freq 2 refer to the first- and second-level over-frequency protection thresholds (in Hz). These values are typically based on the system's nominal frequency (e.g., 50Hz or 60Hz).

7.9 Generator Port Settings Menu

Gen Port Function

Select the functional mode of the generator port. Available options:



None: No function assigned. This is the default setting.

Generator: The port is used as an input for generator power. Once the generator starts, its

power is used to charge the battery.

Smart Load: The port is used as a dedicated load output, with user-defined working conditions for smart load control.

When Gen Port Function is set to Generator, the following parameters become effective:

Gen Warm Time:

Generator warm-up time. After the inverter sends the start signal, it waits for this duration before accepting generator input.

Start SOC / Stop SOC:

Battery SOC thresholds for starting and stopping the generator automatically.

Gen Rated Power:

Maximum power output of the generator.

Max Run Time:

Maximum continuous run time for the generator. Applies when the inverter is automatically controlling the generator.

Cooling Time:

Generator cooldown period after stopping. Applies to inverter-controlled generator operation.

Gen Force:

Force Start Generator function. Should be enabled during the first-time connection of a generator to ensure recognition and activation.

Smart Load Configuration

This configuration page becomes effective only when Gen Port Function is set to Smart Load.

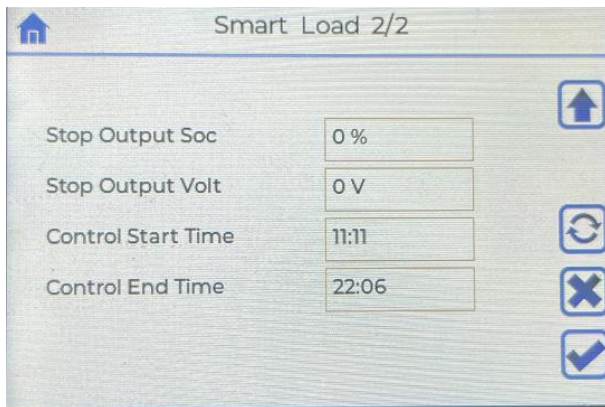

Stop Output SOC:

When the battery SOC drops to this threshold, the smart load output will automatically disconnect.

Stop Output Volt:

If voltage-based control is selected, the smart load output will disconnect when the battery voltage reaches this value.

Control Start Time:

Start of the time window during which the SOC or voltage control conditions are valid.

Control End Time:

End of the time window during which the SOC or voltage control conditions are valid.

Note:

Outside the defined time window, the smart load output is not restricted by SOC or voltage conditions, and will follow the same discharge behavior as the EPS output.

Accessing Generator Data from the Home Page

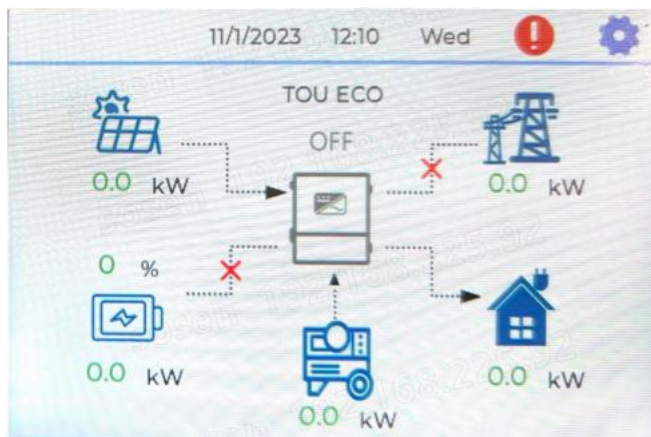

Once the generator function is enabled, a generator icon will appear on the home screen.

Clicking this icon will navigate to the Generator Details Page.

Generator Details Page

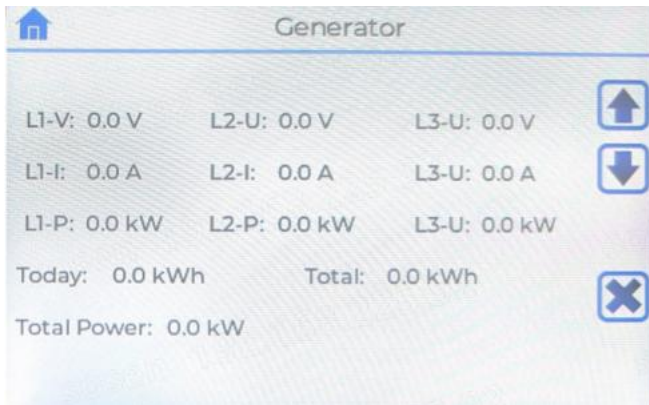

L1 / L2 / L3:

Displays the voltage, current, and power of each phase.

Additional Information:

Today's Generated Energy

Total Historical Generation

Total Generator Power Output

7.10 Advanced Settings Menu

This page allows configuration of parallel settings, Wi-Fi baud rate, and EMS communication parameters.

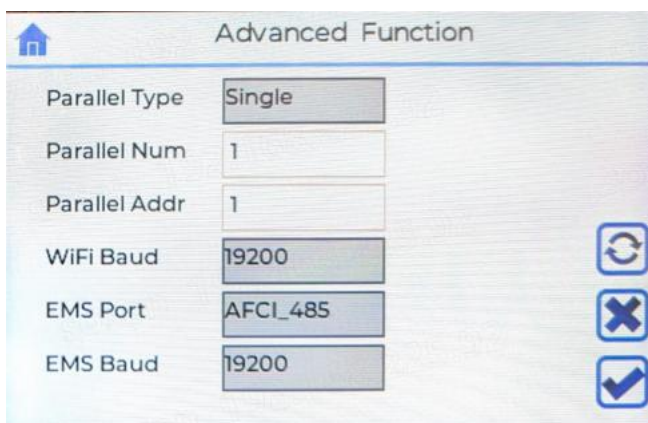

1.Parallel Settings

Parallel Type:

Sets the parallel operation mode of the system.

Parallel Num:

Specifies the total number of inverters in the system (Master + Slaves).

Parallel Addr:

Sets the inverter address in the system.

The master inverter is always set to address 1.

Slave inverters follow in sequential order (2, 3, ...).

2.WiFi Baud:

Baud rate for communication between inverter and data logger.

EMS Port:

Designates the spare RS485 port on the inverter for EMS (Energy Management System) communication.

Default setting: AFCL_485 (can be changed based on actual use).

EMS Baud:

Sets the communication baud rate for the EMS Port.

Default value: 19200.

3. Parallel Configuration Screens – Example of 3-Inverter System

The following screenshots demonstrate how to configure a parallel system with one master inverter and two slave inverters. All settings must be consistent across devices, except for Parallel Addr, which should be unique per unit.

(1) Master Inverter Configuration

Advanced Function	
Parallel Type	Master
Parallel Num	3
Parallel Addr	1
WiFi Baud	19200
EMS Port	AFCI_485
EMS Baud	19200

Parallel Type: Master

Parallel Num: 3 (total number of inverters)

Parallel Addr: 1

WiFi Baud: 19200

EMS Port: APCI_485

EMS Baud: 19200

This inverter is designated as the master unit, responsible for synchronization and control across the entire system.

(2) Slave Inverter 1 Configuration

Advanced Function	
Parallel Type	Slave
Parallel Num	3
Parallel Addr	2
WiFi Baud	19200
EMS Port	AFCI_485
EMS Baud	19200

Parallel Type: Slave

Parallel Num: 3

Parallel Addr: 2

WiFi Baud: 19200

EMS Port: APCI_485

EMS Baud: 19200

This inverter operates as Slave 1, assigned address 2.

(3)Slave Inverter 2 Configuration

Advanced Function	
Parallel Type	Slave
Parallel Num	3
Parallel Addr	3
WiFi Baud	19200
EMS Port	AFCI_485
EMS Baud	19200

Parallel Type: Slave

Parallel Num: 3

Parallel Addr: 3

WiFi Baud: 19200

EMS Port: APCI_485

EMS Baud: 19200

This inverter operates as Slave 2, assigned address 3.

-Important Notes:

1. All inverters must have the same WiFi Baud rate and EMS Baud rate.
2. Ensure proper wiring and grounding between all units.
3. Make sure firmware versions are consistent across all inverters.
4. Communication cables (e.g. RS485 or CAN) must be securely connected.

7.11 Record Menu

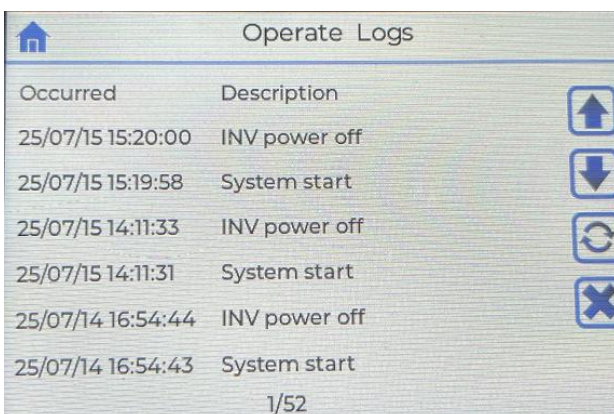
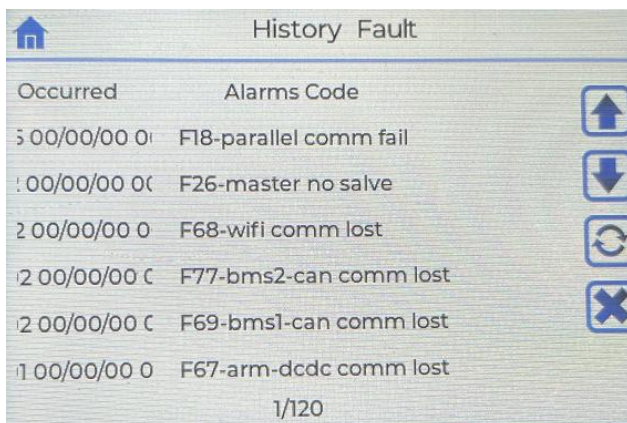
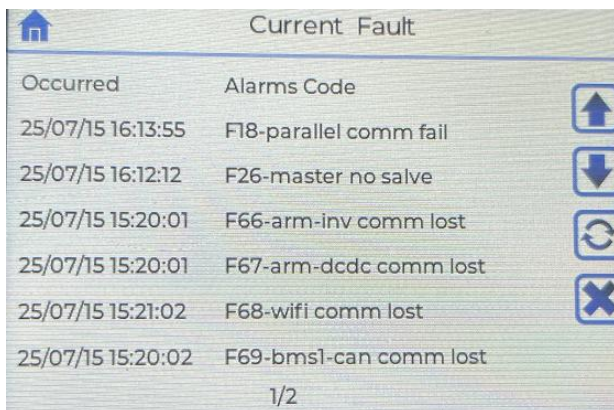
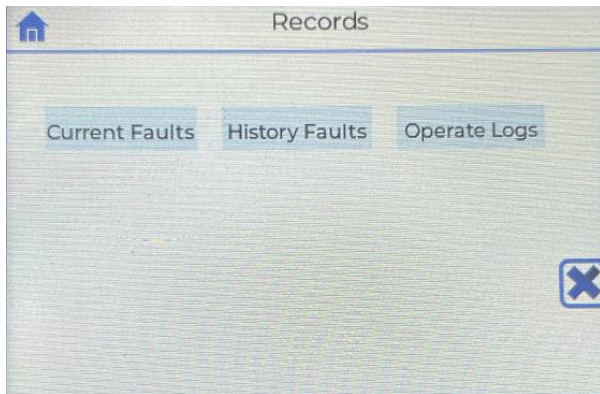

Fault and Operation Logs

Current Fault:

Displays the inverter's active faults and alarms.

It includes the timestamp, fault code, and fault description of the current issue.

History Fault:

Shows the inverter's fault and alarm history.

It records the start time, recovery time, and details of each fault event.

Operate Logs:

Contains logs of user operations such as changing inverter modes, powering the system on/off, or adjusting system settings.

These logs are useful for tracking system changes and user actions.

7.12 Device Info Setup Menu

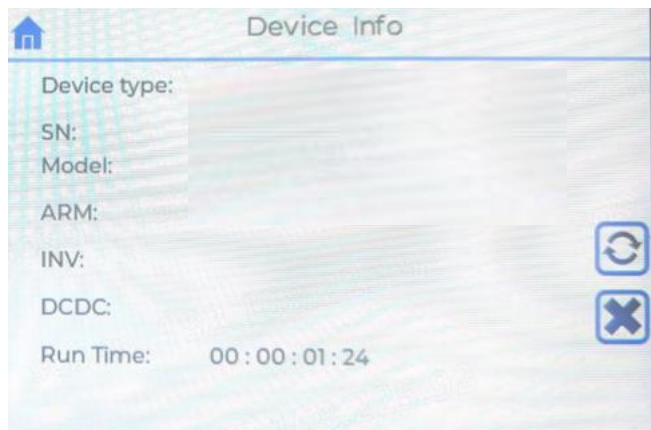

This page displays basic information about the inverter, including:

Device Type:The category or class of the inverter.

Model Number:The specific model identifier.

Serial Number:The unique identifier assigned to each unit.

Software Version:The currently installed firmware/software version.(ARM,INV,DCDC)

Run Time:Total runtime of the inverter since initial operation.

This page is useful for system diagnostics, firmware tracking, and technical support.

7.13 Factory Setting Menu

Reserved: This function is reserved. It is not recommended. Please inform the manufacturer/installer before setting up

Factory Setting 1/3

DRM	<input type="checkbox"/> No	Preventive PID	<input type="checkbox"/> No
Factory Reset	<input type="checkbox"/> No	Active island	<input type="checkbox"/> No
AFCI	<input type="checkbox"/> No	BatTempCompen	<input type="checkbox"/> No
Bat Warn	<input checked="" type="checkbox"/> Yes	Bat Wake-up	<input type="checkbox"/> No
GRID Warn	<input type="checkbox"/> No	ISO	<input type="checkbox"/> No
Ext-Control	<input type="checkbox"/> No	Leakage Curr	<input type="checkbox"/> No

Navigation icons: Home, Down Arrow, Refresh, X, Checkmark

Factory Setting 2/3

Device Reset	<input type="checkbox"/> No	MPPT Ctrl Mode	<input type="text" value="MPPT"/>
Record Clear	<input type="checkbox"/> No	MPPT Para Mode	<input type="text" value="Two-Para"/>
AFCI Alarm Clear	<input type="checkbox"/> No	MPPT Num	<input type="text" value="2"/>
Relay self-test	<input type="checkbox"/> No	MPPT Power	<input type="text" value="30 kW"/>
Device lock	<input type="checkbox"/> No	MPPT Disturbed	<input type="text" value="8"/>
Exec quick	<input type="checkbox"/> No	CVT Volt	<input type="text" value="500 V"/>

Navigation icons: Home, Up Arrow, Down Arrow, Refresh, X, Checkmark

Factory Setting 2/3

Device Reset	<input type="checkbox"/> No	MPPT Ctrl Mode	<input type="text" value="MPPT"/>
Record Clear	<input type="checkbox"/> No	MPPT Para Mode	<input type="text" value="Two-Para"/>
AFCI Alarm Clear	<input type="checkbox"/> No	MPPT Num	<input type="text" value="2"/>
Relay self-test	<input type="checkbox"/> No	MPPT Power	<input type="text" value="30 kW"/>
Device lock	<input type="checkbox"/> No	MPPT Disturbed	<input type="text" value="8"/>
Exec quick	<input type="checkbox"/> No	CVT Volt	<input type="text" value="500 V"/>

Navigation icons: Home, Up Arrow, Down Arrow, Refresh, X, Checkmark

8.Trouble Shooting

This section contains information and procedures for solving possible problems with the SSE-HL10-16K-P1EU series inverters, and provides you with trouble shooting tips to identify and solve most problems that could occur with the SSE-HL10-16K-P1EU series inverters.

This section will help you narrow down the source of any problems you may encounter. Please read the following trouble shooting steps.

Check the warning or fault messages on the System Control Panel or Fault codes on the inverter information panel. If a message is displayed, record it before doing anything further. Attempt the solution indicated in below table.

Error code	Description	Solutions
F01	inv over volt	The inverter is faulty. Turn off the PV, grid, and battery, and wait 5 minutes before turning on the inverter. Check whether the problem is resolved. Or seek help from us, if not go back to normal state.
F02	inv under volt	
F03	short circuit	
F04	inv over curr	
F05	over load	If the load power is too high or the device is downgraded, please reduce the power consumption. Or seek our help if you are unable to return to a normal state.
F07	inv bus over volt	The inverter is faulty. Turn off the PV, grid, and battery, and wait 5 minutes before turning on the inverter. Check whether the problem is resolved. Or seek help from us, if not go back to normal state.
F08	inv bus under volt	
F09	bus unbalance	
F10	leakage self-test fail	
F11	leakage over limit	
F12	relay self-test fail	
F13	inv locked	The inverter is faulty. Turn off the PV, grid, and battery, and wait 5 minutes before turning on the inverter. Check whether the problem is resolved. Or seek help from us, if not go back to normal state.
F14	busbar buffer fail	
F15	inv over temp	
F17	parallel total count err	Check whether the parallel communication cable is properly connected. Or seek help from us, if not go back to normal state.
F18	parallel comm fail	
F19	parallel SW mismatch	
F20	parallel HW mismatch	
F21	parallel model mismatch	
F22	parallel para sync	
F23	master conflict	
F24	slave id conflict	
F25	parallel signal err	
F26	master no salve	
F33	inv flash fault	The internal communication and storage are abnormal. Turn off the PV, grid, and battery, and wait 5 minutes before turning on the
F34	inv-dc comm fault	
F35	inv phase-locked	

F36	inner para match fail	inverter. Check whether the problem is resolved.Or seek help from us, if not go back to normal state.
F37	self-test fail(Italy)	
F38	inv master fault	
F39	inv parallel comm fail	
F40	inv parallel signal err	
F41	inv curr DC component high	
F42	inv parallel overload	
F43	inv load curr unbalance	
F44	inv parallel system fault	
F49	dc bus over volt	
F50	dc bus under volt	
F51	midbus over volt	
F52	midbus under volt	
F53	dc bat disch OC	
F54	dc bat ch OC	
F55	LLC HW over curr	
F56	dc bat over volt	
F57	dc bat under volt	
F60	bat reverse connect	Check whether the positive and negative terminals of the battery power line are connected in reverse mode.
F63	dc over temp	Ensure that the inverter is installed in a place without direct sunlight. Make sure the inverter is installed in a cool/well-ventilated area. Ensure that the inverter is installed vertically and the ambient temperature is lower than the upper limit of the inverter temperature.
F65	meter comm lost	Check whether the meter communication line is normal.
F66	arm-inv comm lost	The internal communication and storage are abnormal. Turn off the PV, grid, and battery, and wait 5 minutes before turning on the inverter. Check whether the problem is resolved.Or seek help from us, if not go back to normal state.
F67	arm-dcdc comm lost	
F68	wifi comm lost	Please check wifi LED light status.Or seek help from us, if not go back to normal state.
F69	bms1-can comm lost	Make sure the battery you use is compatible with the inverter. Check whether the communication cables or ports between the battery and the inverter are properly connected
F70	dsp para match err	The internal communication and storage are abnormal. Turn off the PV, grid, and battery, and wait 5 minutes before turning on the

		inverter. Check whether the problem is resolved.Or seek help from us, if not go back to normal state.
F71	EPO	Seek help from us, if not go back to normal state.
F72	ambient temp high	Ensure that the inverter is installed in a place without direct sunlight. Make sure the inverter is installed in a cool/well-ventilated area. Ensure that the inverter is installed vertically and the ambient temperature is lower than the upper limit of the inverter temperature.
F73	bms1-485 comm lost	Make sure the battery you use is compatible with the inverter. Check whether the communication cables or ports between the battery and the inverter are properly connected
F74	arm flash error	The internal communication and storage are abnormal. Turn off the PV, grid, and battery, and wait 5 minutes before turning on the inverter. Check whether the problem is resolved.Or seek help from us, if not go back to normal state.
F75	NTC disconnect	
F76	dsp para set fail	
F81	dc-inv comm lost	
F82	dc flash fault	
F83	dc fault locked	
F84	12V aux fault	
F87	PV1 over volt	The inverter is faulty. Turn off the PV, grid, and battery, and wait 5 minutes before turning on the inverter. Check whether the problem is resolved.Or seek help from us, if not go back to normal state.
F88	PV2 over volt	
F89	PV1 over curr	
F90	PV2 over curr	
F91	PV1 reverse connect	Check whether the PV cables are correctly connected.
F92	PV2 reverse connect	
F96	ISO fault	Seek help from us, if not go back to normal state.
Warning code	Description	Solutions
W01	over load	If the load power is too high or the device is downgraded, please reduce the power consumption. Or seek our help if you are unable to return to a normal state.
W02	inv over temp	Ensure that the inverter is installed in a place without direct sunlight. Make sure the inverter is installed in a cool/well-ventilated area. Ensure that the inverter is installed vertically and the ambient temperature is

		lower than the upper limit of the inverter temperature.
W03	grid over freq	If the power grid is abnormal, the inverter automatically returns to the normal working state after the power grid recovers. Or seek help from us, if not go back to normal state. *GARDA(Power grid amplitude quick check alarm)
W04	grid under freq	
W05	grid over volt	
W06	grid under volt	
W07	grid lost phase	
W08	grid long time OV	
W09	grid phase error	
W10	GARDA	
W11	grid DC component rapid detection	
W12	grid phase rapid inspection	
W13	dc bat over volt	If the internal fault of the lithium battery occurs, Turn off the PV, grid, and battery, and wait 5 minutes to turn on the inverter and lithium battery. Check whether the problem is resolved. Or seek help from us, if not go back to normal state.
W14	dc bat under volt	
W15	bat none-connected	The inverter does not detect the battery voltage. Ensure that the battery switch system is started and cables are properly connected.
W16	dc over temp	Ensure that the inverter is installed in a place without direct sunlight. Make sure the inverter is installed in a cool/well-ventilated area. Ensure that the inverter is installed vertically and the ambient temperature is lower than the upper limit of the inverter temperature.
W17	soc1 low	Check Battery communication status.Or seek help from us, if not go back to normal state.
W18	bat ch&disch limit	
W21	PV1 under volt	Turn off the PV, grid, and battery, and wait 5 minutes before turning on the inverter. Check whether the problem is resolved.Or seek help from us, if not go back to normal state.
W22	PV2 under volt	
W28	gen volt abnormal	Measure the generator output voltage using a multimeter. Ensure the generator is operating within its rated voltage (typically 220/230V or 380/400V depending on the system). Check for loose or faulty wiring between the generator and inverter input.
W29	gen freq abnormal	Check the generator frequency output with a

		<p>frequency meter.</p> <p>Make sure the generator engine speed is stable (RPM too high or low will affect frequency).</p> <p>Adjust the engine governor if needed.</p> <p>Avoid overloading the generator, which may cause frequency fluctuations.</p>
W30	gen phase abnormal	<p>Verify the phase sequence (e.g., R-S-T) using a phase rotation tester.</p> <p>Ensure all generator output phases are properly connected and no wires are loose or damaged.</p> <p>Check for any single-phase load imbalance or internal generator phase loss.</p> <p>For three-phase systems, confirm that generator and inverter phase sequences match.</p>
W31	slave comm fail	<p>Check parallel settings. Or seek help from us, if not go back to normal state.</p>

 **NOTICE**

If your inverters information panel is not displaying a Fault light, check the following list to make sure that the present state of the installation allows proper operation of the unit.

Is the inverter located in a clean, dry, and adequately ventilated place?

Have the DC input breakers been opened?

Are the cables adequately sized and short enough?

Are the input and output connections and wiring in good condition?

Are the configurations settings correct for your particular installation?

Are the display panel and the communications cable properly connected and undamaged?

Contact Customer Service for further assistance. Please be prepared to describe details of your system installation and provide the model and serial number of the unit.

9.Maintenance

9.1 Power ON the Inverter for first time



Important: Please follow these steps to turn on the inverter.

Step 1: Press the Power on/off button to turn on the device, and keep the button pressed.

Step 2: make the PV SWITCH to the ON position.

Step 3: Turn on the battery. Turn on the DC switch between battery and inverter.

Step 4: Turn on the AC circuit breaker between the inverter port and the power grid.

Step 5: Open the AC circuit breaker between the inverter load port and the emergency load.

Step 6: Manually send the startup command through the APP (for safety, it can be set to automatic startup after the initial power-on).

Step 7: The inverter should start running now.

9.2 Power Off the Inverter



- Power off the inverter before operations and maintenance. Otherwise, the inverter may shocks or occur.
- Delayed discharge. Wait until the components are discharged after power off.

Step 1: Turn off the AC breaker on the ON-GRID side of the inverter.

Step 2: Turn off the AC breaker on the BACK-UP side of the inverter.

Step 3: Turn off the battery breaker between the inverter and the battery.

Step 4: Turn off the PV switch of the inverter.

9.3 Removing the Inverter



- Make sure that the inverter is powered off.
- Wear proper PPE before any operations.

Step 1: Disconnect all the cables, including DC cables, AC cables, communication cables, the communication module, and PE cables.

Step 2: Remove the inverter from the mounting plate.

Step 3: Remove the mounting plate.

Step 4: Store the inverter properly. If the inverter needs to be used later, ensure that the storage conditions meet the requirements.

9.4 Disposing of the Inverter

If the inverter cannot work anymore, dispose of it according to the local disposal requirements, The inverter cannot be disposed of together with household waste.



- Make sure that the inverter is powered off.
- Wear proper PPE before any operations.

9.5 Routine Maintenance

Maintaining Item	Maintaining Method	Maintaining Period
System Clean	Check the heat sink, air intake, and air outlet for foreign matter or dust.	Once 6-12 months
PV Switch	Turn the DC switch on and off ten consecutive times to make sure that it is working properly.	Once a year
Electrical Connection	Check whether the cables are securely connected. Check whether the cables are broken or whether there is any exposed copper core.	Once 6-12 months
Sealing	Check whether all the terminals and ports are properly sealed. Reseal the cable hole if it is not sealed or too big.	Once a year