

User Manual

Hybrid Inverter

SSE-HH3K-6K-P1-EU/AU/BE Series



SSE-HH3K-P1-EU/AU
SSE-HH3K7-P1-EU/AU
SSE-HH4K6-P1-EU/AU
SSE-HH5K-P1-EU/AU/BE
SSE-HH6K-P1-EU/AU

Please read this manual before use and follow its guidance.
Keep this manual for future reference.

CONTENTS

1. About This Manual	1
1.1 Applicable Model	1
1.2 Target Audience	1
1.3 Symbol Definition	1
1.4 Updates	1
2. Safety Precaution	2
2.1 General Safety	2
2.2 PV String Safety	2
2.3 Inverter Safety	2
2.4 Battery Safety	3
2.5 Personal Requirements	3
2.6 EU Declaration of Conformity	4
3. Product Introduction	4
3.1 Product Features	4
3.2 Working Mode	6
3.3 Appearance	7
3.3.1 Dimension	7
3.3.2 Ports	7
3.3.3 Nameplate	8
3.3.4 Features	9
3.3.5 Specification	9
4. Check and Storage	12
4.1 Check Before Receiving	12
4.2 What' in the box?	12
4.3 Storage	13
5. Installation	13
5.1 Installation Requirements	13
5.2 Inverter Installation	16
5.2.1 Moving the Inverter	16
5.2.2 Installing Steps	16
6. Electrical Connection	17
6.1 Safety Precaution	17
6.2 Connection Port Description	18
6.3 PE Cable Connection	18
6.4 AC Connection	19
6.5 PV Connection	22
6.6 Battery Connection	23
6.7 Communication Device Installation (Optional)	25
6.8 Wi-Fi&BLE stick installation	27
7. Operation	29
7.1 Indicator panel	29
8. Trouble Shooting	30
9. Maintenance	32
9.1 Power Off the Inverter	32
9.2 Removing the Inverter	32
9.3 Disposing of the Inverter	33
9.4 Routine Maintenance	33

1.About This Manual

This manual describes the product information, installation, electrical connection, commissioning, troubleshooting, and maintenance. Read through this manual before installing and operating the product. All the installers and users have to be familiar with the product features, functions, and safety precautions. This manual is subject to update without notice. For more product details and latest documents, visit <https://www.sosencx.com>.

1.1 Applicable Model





Model	Nominal Output Power	Nominal Output Voltage
SSE-HH3K-P1-EU/AU	3000W	230V a.c
SSE-HH3K7-P1-EU/AU	3680W	230V a.c
SSE-HH4K6-P1-EU/AU	4600W	230V a.c
SSE-HH5K-P1-EU/AU/BE	5000W	230V a.c
SSE-HH6K-P1-EU/AU	6000W	230V a.c

1.2 Target Group

This manual is intended for qualified and knowledgeable electrical technical personnel who are responsible for hybrid inverter installation and commissioning in the energy storage system and electric system.

1.3 Symbol Definition

The following types of safety instructions and general information appear in this document as described below:

 DANGER	 WARNING	 CAUTION	 NOTICE
“Danger” indicates a hazardous situation with a high level of risk that, if not avoided, will result in death or serious injury.	“Warning” indicates a hazardous situation with a medium level of risk that, if not avoided, could result in death or serious injury.	“Caution” indicates a hazardous situation with a low level of risk that, if not avoided, could result in minor or moderate injury.	“Notice” provides some tips and methods to solve product-related problems to save time.

1.4 Updates

The latest document contains all the updates made in earlier issues.

- V01 2023-11-22
- V02 2025-7-21
- V03 2026-2-3

- First Issue

2.Safety Precaution

Please strictly follow these safety instructions in the user manual during the operation.

2.1 General Safety

NOTICE

- The information in this user manual is subject to change due to product updates or other reasons. This guide cannot replace the product labels or the safety precautions in the user manual unless otherwise specified. All descriptions here are for guidance only.
- Before installations, read through the quick installation guide. For additional information, please see the user manual.
- All installations should be performed by trained and knowledgeable technicians who are familiar with local standards and safety regulations.
- Use insulating tools and wear personal protective equipment when operating the equipment to ensure personal safety. Wear anti-static gloves, cloths, and wrist strips when touching electron devices to protect the inverter from damage.
- Strictly follow the installation, operation, and configuration instructions in this manual. The manufacturer shall not be liable for equipment damage or personal injury if you do not follow the instructions. For more warranty details, please visit <https://www.sosencx.com/>.

2.2 PV String Safety

DANGER

Connect the DC cables using the delivered PV connectors. The manufacturer shall not be liable for the equipment damage if other connectors or terminals are used.

WARNING

- Ensure the component frames and the bracket system are securely grounded.
- Ensure the DC cables are connected tightly, securely, and correctly.
- Measure the DC cables with a multimeter to avoid reverse polarity connection. Also, the voltage should be under the permissible range.
- Do not connect one PV string to more than one inverter at the same time. Otherwise, it may cause damage to the inverter.
- The PV modules used with the inverter must have an IEC61730 class A rating.
- When the photovoltaic array is exposed to light, it supplies a d.c. voltage to the inverter.











2.3 Inverter Safety

WARNING

- The voltage and frequency at the connecting point should meet the on-grid requirements.
- Additional protective devices like circuit breakers or fuses are recommended on the AC side. Specification of the protective device should be at least 1.25 times the AC rated output current.
- Make sure that all the groundings are tightly connected. When there are multiple inverters, make sure that all the grounding points on the enclosures are equip Potential bonding.
- It should be taken into account the characteristics of photovoltaic power instability, if the battery is not connected, there is no EPS function.

⚠ DANGER

- All labels and warning marks should be visible after the installation. Do not cover, scrawl, or damage any label on the equipment.
- Warning labels on the inverter are as follows:

	DANGER High voltage hazard. Disconnect all incoming power and turn off the product before working on it.		Delayed discharge. Wait 5 minutes after power off until the components are completely discharged.
	Read through the user manual before working on this device.		Potential risks exist. Wear proper PPE before any operations.
	High-temperature hazard. Do not touch the product under operation to avoid being burnt.		Grounding point.
	With CE mark & the inverter fulfills the basic requirements of the guideline governing Low-Voltage and electro-magnetic compatibility.		Do not dispose of the inverter as household waste. Discard the product in compliance with local laws and regulations, or send it back to the manufacturer.
	UKCA marking Indicates compound UK product safety certification requirements.		RCM marking

2.4 Battery Safety

⚠ WARNING

- The battery used with the inverter shall be approved by the inverter manufacturer. The approved battery list can be obtained through the official website.
- Before installations, read through the corresponding battery's User Manual to learn about the product and the precautions. Strictly follow its requirements.
- If the battery discharged completely, please charge it in strict accordance with the corresponding model's User Manual.
- Factors such as: temperature, humidity, weather conditions, etc. may limit the battery's current and affect its load.
- Contact after-sale service immediately if the battery is not able to be started. Otherwise, the battery might be damaged permanently.
- Use the multimeter to measure the DC cable to avoid reverse polarity connection. Also, the voltage should be under the permissible range.
- Do not connect one battery group to several inverters at the same time. Otherwise, it may cause damage to the inverter.

2.5 Personal Requirements

💡 NOTICE

- Personnel who install or maintain the equipment must be strictly trained, learn about safety precautions and correct operations.
- Only qualified professionals or trained personnel are allowed to install, operate, maintain, and replace the equipment or parts.

2.6 EU Declaration of Conformity

Shenzhen Sosen Innovation Technology Co., Ltd. hereby declares that the inverter with wireless communication modules sold in the European market meets the requirements of the following directives:

- Radio Equipment Directive 2014/53/EU (RED)
- Restrictions of Hazardous Substances Directive 2011/65/EU and (EU) 2015/863 (RoHS)
- Waste Electrical and Electronic Equipment 2012/19/EU
- Registration, Evaluation, Authorization and Restriction of Chemicals (EC) No 1907/2006 (REACH)

Shenzhen SOSEN Innovation Technology Co., Ltd. hereby declares that the inverter without wireless communication modules sold in the European market meets the requirements of the following directives:

- Electromagnetic compatibility Directive 2014/30/EU (EMC)
- Electrical Apparatus Low Voltage Directive 2014/35/EU (LVD)
- Restrictions of Hazardous Substances Directive 2011/65/EU and (EU) 2015/863 (RoHS)
- Waste Electrical and Electronic Equipment 2012/19/EU
- Registration, Evaluation, Authorization and Restriction of Chemicals (EC) No 1907/2006 (REACH)

You can download the EU Declaration of Conformity on <https://sosencx.com>.

3. Product Introduction

3.1 Product Features

Intended usage

The SSE-HH3K-6K-P1-EU/AU series hybrid inverters apply to energy storage system with battery, loads and grid. The energy produced by PV system shall be used to optimize self-consumption, excess power charge battery and the rest power could be fed into the grid. Battery shall be discharged to support loads when PV power is insufficient to meet self-consumption. If both PV power and battery power is insufficient, the system will take power from grid to support loads. Work mode depends on PV energy and user's preference.

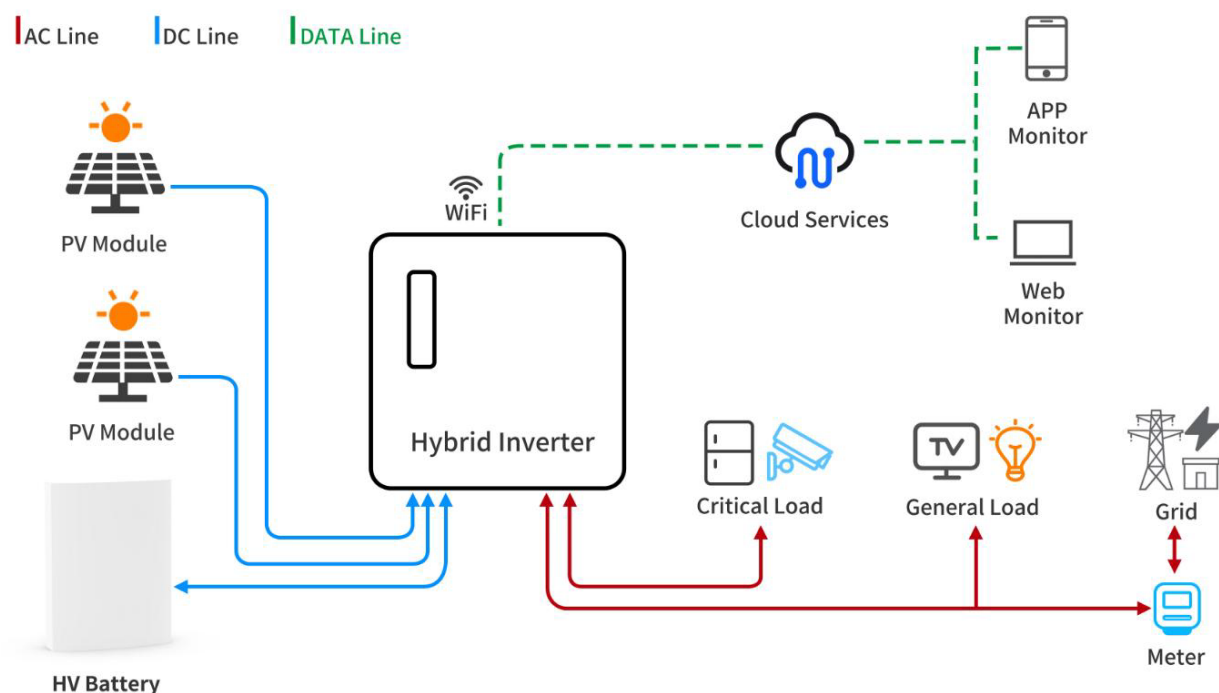

Model

This manual applies to the listed inverters below:

SSE-HH3K-P1-EU/AU SSE-HH3K7-P1-EU/AU SSE-HH4K6-P1-EU/AU SSE-HH5K-P1-EU/AU SSE-HH6K-P1-EU/AU

Model description

SS E - H H 6K - P1 - EU

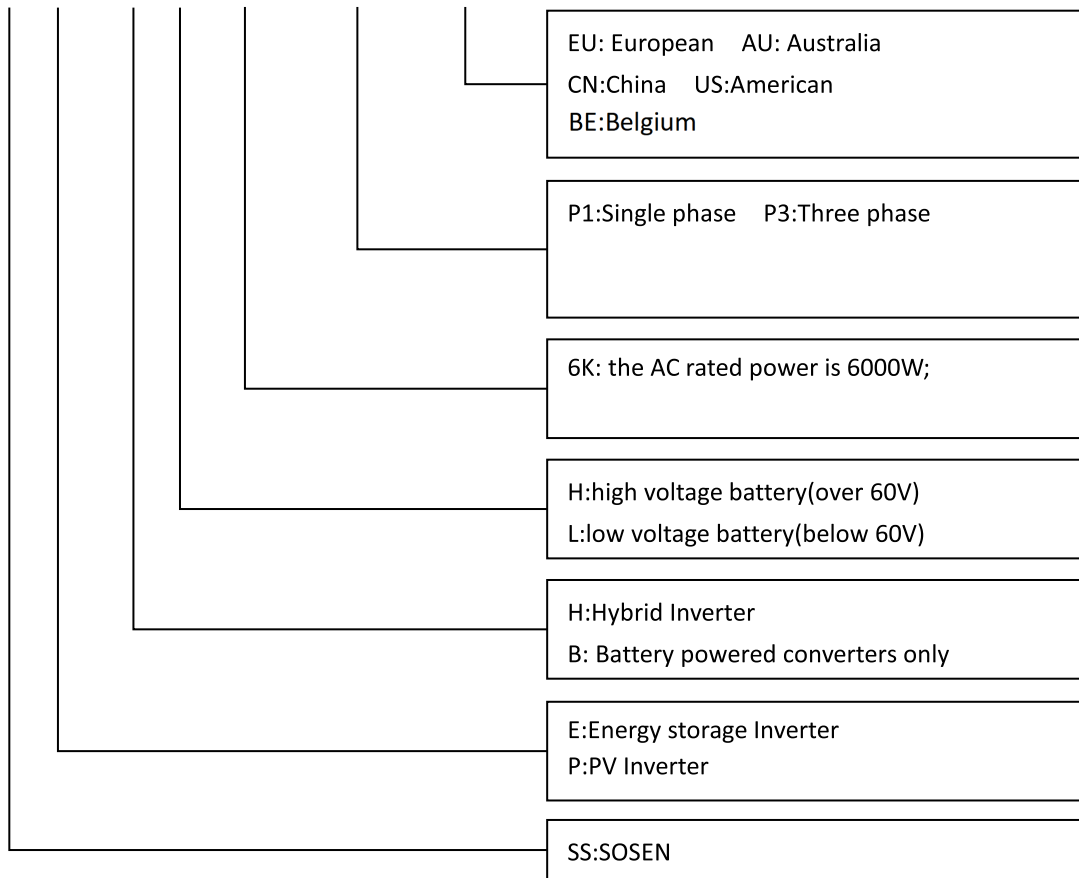

3.2 Working Mode

The SSE-HH3K-6K-P1-EU/AU Series hybrid inverter has the following work modes based on your configuration and layout conditions.

Work modes	Description
Self-use (with PV Power)	Priority: load>battery>grid The energy produced by the PV system is used to optimize self-consumption. The excess energy is used to charge the batteries, then exported to grid.
Self-use (without PV Power)	Priority: load>battery When no PV supplied, battery will discharge for local loads firstly, and grid will supply power when the battery capacity is not enough.
Feed in priority	Priority: load>grid>battery The power generated will be used to supply the local loads firstly, then export to the public grid. The redundant power will charge the battery.
Force time use	Priority: battery>load>grid (when charging) Priority: load>battery>grid (when discharging) This mode applies the area that has electricity price between peak and valley. User can use off-peak electricity to charge the battery. The charging and discharging time can be set flexibly, and it also allows to choose whether charge from the grid or not.
Back up mode	Priority: load>battery When the grid is off, system will supply emergency power from PV or battery to supply the home loads (Battery is necessary in EPS mode).

 **CAUTION**

Make sure the load powering rating in within the EPS's output rating. Or the inverter will shut down with an 'over load' warning. When an "over load" is appeared, adjust the load power make sure it is with the range of the EPS output, and turn the inverter on. For the nonlinear load, please pay attention to the inrush power make sure it is within the range of the EPS output.

3.3 Appearance

3.3.1 Dimension

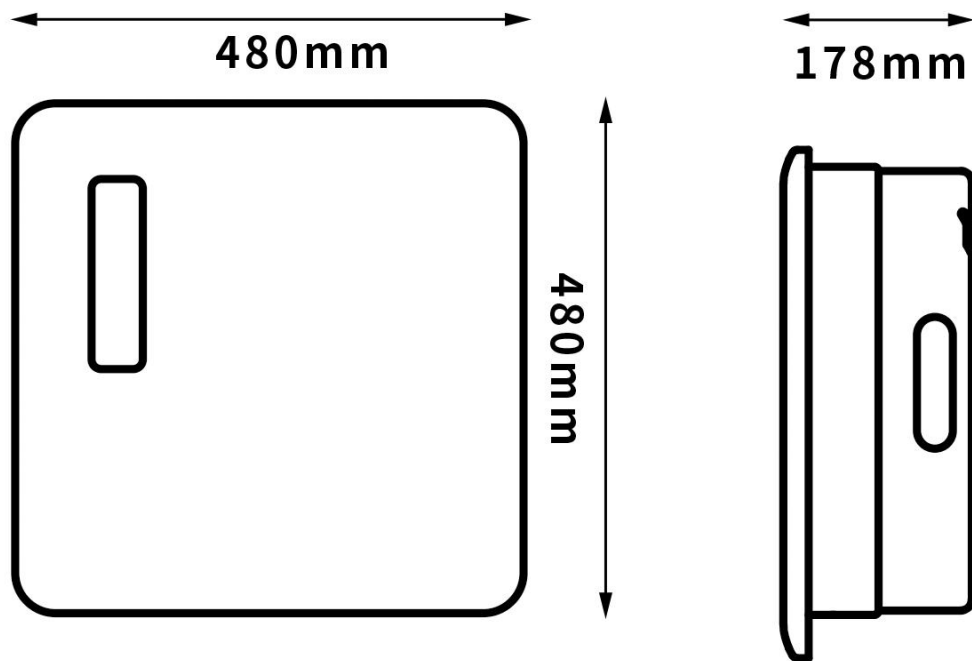

3.3.2 Ports

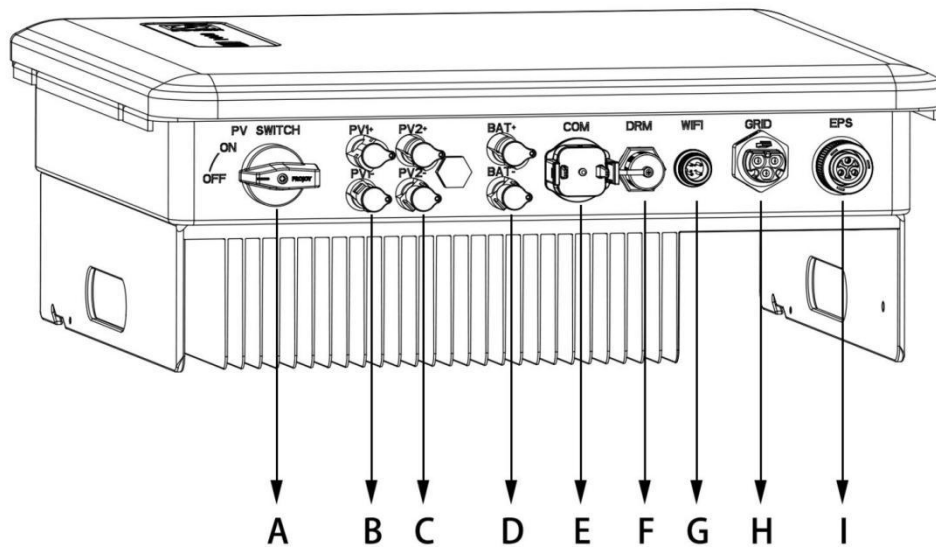

item	Description	item	Description
A	PV switch	B	PV1 connector
C	PV2 connector	D	Battery connector
E	Communication port	F	DRM (Only for Australia)
G	WiFi	H	Grid connector
I	EPS connector		

3.3.3 Nameplate

The nameplate is for reference only.



Hybrid Inverter

Model	SSE-HH6K-P1-EU
Vmax PV(Max.PV input voltage)	600V d.c
PV input operating voltage range	60-550V d.c
Max.operating PV input current	16A d.c*2
Isc PV	24A d.c*2
Grid rated voltage	230V a.c,1W+N+PE
Grid rated frequency	50Hz
Grid rated input current	26.1+26.1A a.c(bypass)
Grid rated output current	26.1A a.c
Grid rated input apparent power	6000+6000VA(bypass)
Grid rated output apparent power	6000VA
EPS rated output voltage	230V a.c,1W+N+PE
EPS rated output frequency	50Hz
EPS rated output current	26.1A a.c
EPS rated output apparent power	6000VA
Power Factor	0.8Leading-0.8Lagging
Battery operation voltage range	85-480V d.c
Max.charge and discharge current	35A d.c
Battery type	Li-ion
Protective class	I
Ingress protection degree	IP65
Overvoltage category	PV: II AC:III
Inverter topology	Non-isolated
Operating temperature range	-25°C -+60°C

Manufacturer:

Shenzhen Sosen Innovation Technology Co.,Ltd

Address601,Pengzhanhui,Building1, No.233, Xinqiao Community Center Road,Xinqiao Street, Bao'an District, Shenzhen, China



3.3.4 Features

- Intelligent energy management
- Multiple operating modes are available
- High efficiency
- Wide range of battery voltage
- Compatible with on grid and off grid
- High speed on/off grid switching
- High Sealed design With IP65

3.3.5 Specification

Model for EU	SSE-HH3K-P1-EU/AU	SSE-HH3K7-P1-EU/AU	SSE-HH4K6-P1-EU/AU	SSE-HH5K-P1-EU/AU	SSE-HH5K-P1-BE	SSE-HH6K-P1-EU/AU
Battery Type	Li-ion					
Battery Voltage range	85-460V d.c					
Full power Battery voltage range	92-460V d.c	112-460V d.c	190-460V d.c	190-460V d.c	190-460V d.c	190-460V d.c
Rated Battery Voltage	300V d.c					
Max.charge/discharge Power	3000W	3680W	4600W	5000W	5000W	6000W
Max Charge Current	35A d.c					
Max Discharge Current	35A d.c					
BMS Communication	CAN, RS485					
Reverse Connect Protection	Yes					
PV Input						
Recommended Max. PV array power for each input	3000W	3680W	4140W	4500W	4500W	4500W
Max. operating PV input current (PV 1/PV 2)	16/16A d.c					
Max. Isc PV (PV 1/PV 2)	24/24 A d.c					
Vmax PV (Max. PV input voltage)	600V d.c					
PV input operating voltage range	80-550V d.c					
MPPT Voltage Range	80-550V d.c					
Full power MPPT voltage range	220-520V d.c					
Start-up Voltage	75V d.c					
Number of MPP Trackers	2					
Strings per MPP Tracker	1					
Number of PV input	2					
Grid AC input and AC output						
Grid rated voltage	220/230/240V a.c, 1W+N+PE					
Grid rated frequency	50/60Hz					
Grid rated input active power	3000W+ 3000W(bypass)	3680W+ 3680W(bypass)	4600W+ 4600W(bypass)	5000W+ 5000W(bypass)	5000W+ 5000W(bypass)	6000W+ 6000W(bypass)
Grid rated input apparent power	3000VA+ 3000VA(bypass)	3680VA+ 3680VA(bypass)	4600VA+ 4600VA(bypass)	5000VA+ 5000VA(bypass)	5000VA+ 5000VA(bypass)	6000VA+ 6000VA(bypass)
Grid Max. input active power	3300W+ 3300W(bypass)	4048W+ 4048W(bypass)	4600W+ 4600W(bypass)	5500W+ 5500W(bypass)	5000W+ 5000W(bypass)	6600W+ 6600W(bypass)
Grid Max. input apparent power	3300VA+ 3300VA(bypass)	4048VA+ 4048VA(bypass)	4600VA+ 4600VA(bypass)	5500VA+ 5500VA(bypass)	5000VA+ 5000VA(bypass)	6600VA+ 6600VA(bypass)

Grid rated output active power	3000W	3680W	4600W	5000W	5000W	6000W
Grid rated output apparent power	3000VA	3680VA	4600VA	5000VA	5000VA	6000VA
Grid Max. output active power	3300W	4048W	4600W	5500W	5000W	6600W
Grid Max. output apparent power	3300VA	4048VA	4600VA	5500VA	5000VA	6600VA
Grid rated input current	13+13A a.c (bypass)	16+16A a.c (bypass)	20+20A a.c (bypass)	21.7+21.7A a.c (bypass)	21.7+21.7A a.c (bypass)	26.1+26.1A a.c (bypass)
Grid rated output current	13A a.c	16A a.c	20A a.c	21.7A a.c	21.7A a.c	26.1A a.c
Grid power factor	0.8 leading to 0.8 lagging					
Grid input and output Inrush current	96A a.c @ 3 μ s					
Max. Grid output fault current	96A a.c @ 3 μ s					
Max. Grid output overcurrent protection	250V a.c /60 A a.c					
Grid input Icc (Rated conditional short-circuit current)	500A a.c					
Grid input Icw (Rated short-time withstand current)	500A a.c					
Total Harmonic Distortion (THDi, rated power)	<3%					
EPS output						
EPS rated output Voltage	220/230/240V a.c, 1W+N+PE					
EPS rated output frequency	50/60Hz					
EPS rated output active power	3000W	3680W	4600W	5000W	5000W	6000W
EPS rated output apparent power	3000VA	3680VA	4600VA	5000VA	5000VA	6000VA
EPS rated output current	13A a.c	16A a.c	20A a.c	21.7A a.c	21.7A a.c	26.1A a.c
EPS output power factor	0.8 leading to 0.8 lagging					
EPS output peak power	6600VA(<10s)					
EPS output Inrush current	96A a.c @ 3 μ s					
EPS Max. output fault current	96A a.c @ 3 μ s					
EPS Max. output overcurrent protection	250V a.c /60 A a.c					
Switch Time	<20ms					
Total Harmonic Distortion (THDv, linear Load)	<2%					
Compatible with the Generator	Optional					
Efficiency	SSE-HH3K-P1-EU	SSE-HH3K7-P1-EU	SSE-HH4K6-P1-EU	SSE-HH5K-P1-EU	SSE-HH5K-P1-BE	SSE-HH6K-P1-EU
MPPT Efficiency	99.90%					
Euro-efficiency	97.00%					
Max. efficiency	97.80%					

Standard	
Safety	IEC 62109-1/2, IEC 62477-1, IEC 62040-1
EMC	IEC 61000-6-1, IEC 61000-6-3
Grid-interactive	EN 50549-1,G99/G98,CEI 0-21, UNE 217001&2/NTS 631,VDE-AR-N 4105, AS/NZS 4777.2 etc.
Environment	
Degree of ingress protection	IP65
Protection class	I
Environment category	Outdoor
Wet location classification	Yes
Pollution degree	PD3
Operating altitude	<2000 m
Operating ambient temperature	-25 - +60 °C (linely derating to 60% when exceed +45 to +60 °C)
Operating relative Humidity	0-100% (non-condensing)
Storage Temperature	-25- +60 °C
Storage relative Humidity	0-100% (non-condensing)
Noise Emission(typical)	<40 db
Overvoltage Category	AC: III, PV: II
Electrical supply system	TN, TT
General Data	
Dimension (WxHxD)	480x480x178mm
Net Weight	20kg
Cooling Mode	Natural Cooling
Topology	Non-isolated
Active anti-islanding method	Active frequency drift
Communication with Meter	RS485
Communication with Portal	Bluetooth/WIFI (Optional)
LED indicator	8 led

4. Check and Storage

4.1 Check Before Receiving

Check the following items before receiving the product.

1. Check the outer packing box for damage, such as holes, cracks, deformation, and others signs of equipment damage. Do not unpack the package and contact the supplier as soon as possible if any damage is found.
2. Check the inverter model. If the inverter model is not what you requested, do not unpack the product and contact the supplier.
3. Check the deliverable for correct model, complete contents, and intact appearance. Contact the supplier as soon as possible if any damage is found.

4.2 What's in the box?

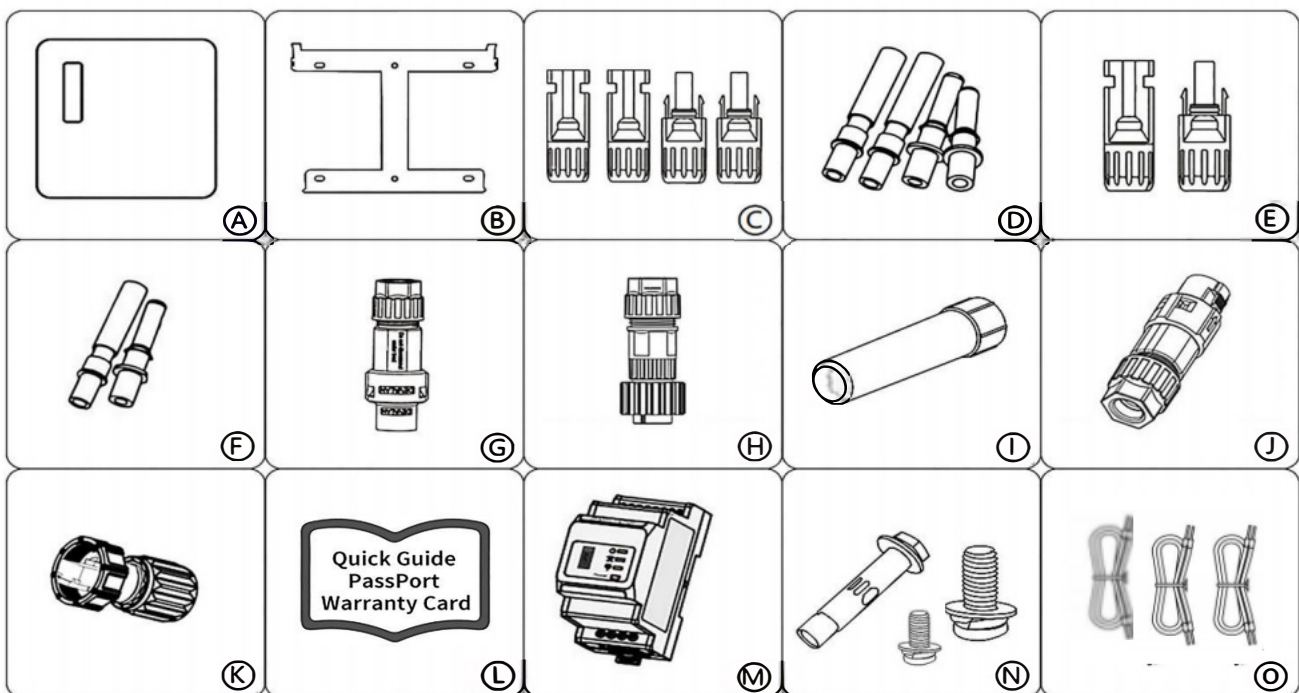

Item	Quantity	Description	Item	Quantity	Description
A	1	Inverter	B	1	Bracket
C	4	PV connectors (Black) (2*positive, 2*negative)	D	4	PV pin contacts(Black) (2*positive, 2*negative)
E	2	Battery connectors(Blue) (1*positive, 1*negative)	F	2	Battery pin contacts(Blue) (1*positive, 1*negative)
G	1	AC EPS terminal(Black)connectors	H	1	AC grid terminal(Blue)connectors
I	1	WiFi module	J	1	COM 16pin connector
K	1	DRM RJ45 connector(only for Australia)	L	3	User Manual&Quick Guide & PassPort &Warranty Card
M	1	DDSU666 Single-phase electronic type guide rail mounting electric energy meter	N	7	M8*80 Expansion bolts *4 & PM6*12×1 &PM4*14×2
O	3	Cables(CAN & RS485)			

4.3 Storage

If the equipment is not to be installed or used immediately, please ensure that the storage environment meets the following requirements:

1. Do not unpack the outer package or throw the desiccant away.
2. Store the equipment in a clean place. Make sure the temperature and humidity are appropriate and no condensation.
3. The height and direction of the stacking inverters should follow the instructions on the packing box.
4. The inverters must be stacked with caution to prevent them from falling.
5. If the inverter has been long term stored, it should be checked by professionals before being put into use.
6. The storage temperature range is: $-25^{\circ}\text{C}\sim 60^{\circ}\text{C}$, and the storage humidity is $0\sim 95\%$.
7. The box should be suitable for loads more than 30kg.



5. Installation

5.1 Installation Requirements

Installation Environment Requirements

1. Do not install the equipment in a place near flammable, explosive, or corrosive materials.
2. Do not install the equipment in a place that is easy to touch, especially within children's reach. High temperature exists when the equipment is working. Do not touch the surface to avoid burning.
3. Avoid the water pipes and cables buried in the wall when drilling holes.
4. Install the equipment in a sheltered place to avoid direct sunlight, rain, and snow. Build a sunshade if it is needed.
5. The place to install the equipment shall be well-ventilated for heat radiation and large enough for operations.
6. The equipment with a high ingress protection rating can be installed indoors or outdoors. The temperature and humidity at the installation site should be within the appropriate range.
7. Install the equipment at a height that is convenient for operation and maintenance, electrical connections, and checking indicators and labels.
8. The altitude to install the inverter shall be lower than the maximum working altitude 2000m.
9. The PV modules used with the inverter must have an IEC61730 class A rating.
10. There should be provided an overcurrent protection (such as a breaker rated 250V a.c /60 A a.c) before AC input and after EPS output, and make sure that the installation position shall not prevent access to the disconnection means.
11. Please ensure that there is adequate ventilation space for the inverter after installation, refer to the installation diagram below.
12. This inverter does not provide an internal isolated transformer between PV input and Battery / AC output circuits, But a basic insulation is provided between PV input / Battery / AC output circuits and metal enclosure / earth, and reinforced / double insulation between PV input / Battery / AC output and communication circuits (DRM / Meter / WiFi/ RS485)
13. The PV input ratings please refer to the specification table of subclause 3.3.5, and please make sure that PV array should not be grounded.
14. Install the equipment away from electromagnetic interference. If there are radio stations or wireless communication equipment below 30 MHz near the installation location, please install the equipment as follows:
 - Add a multi-turn winding ferrite core at the DC input line or AC output line of the inverter, or add a low-pass EMI filter.
 - The distance between the inverter and the wireless EMI equipment is more than 30m.

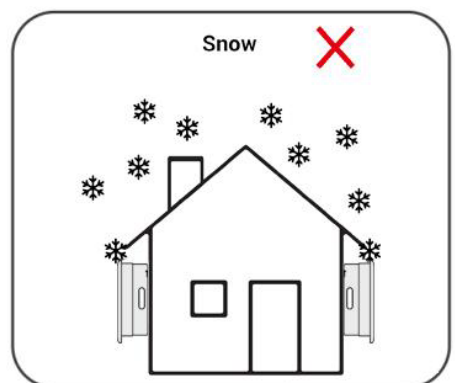
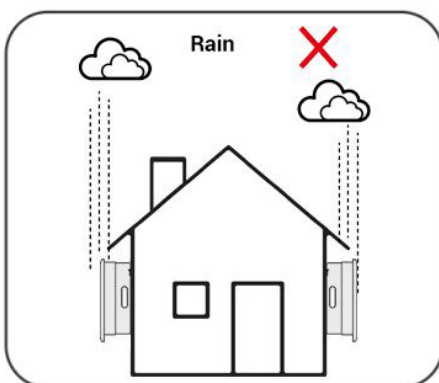
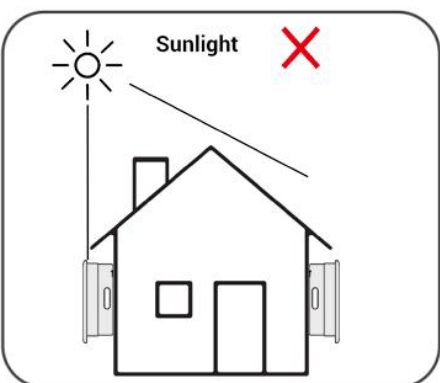
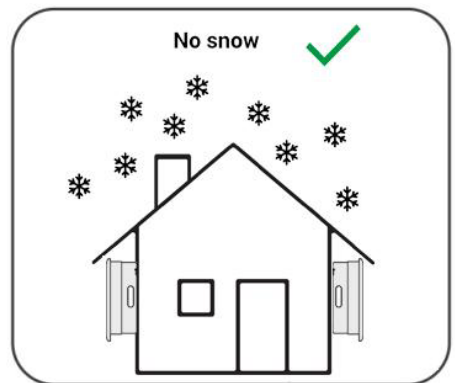
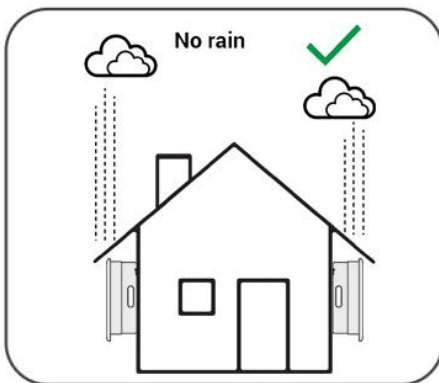
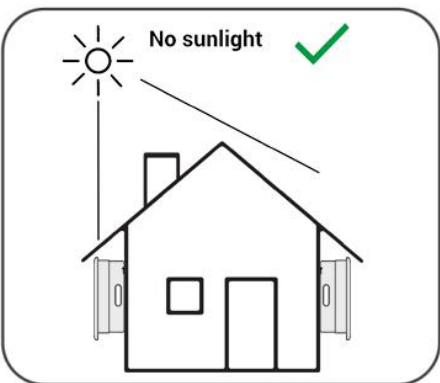
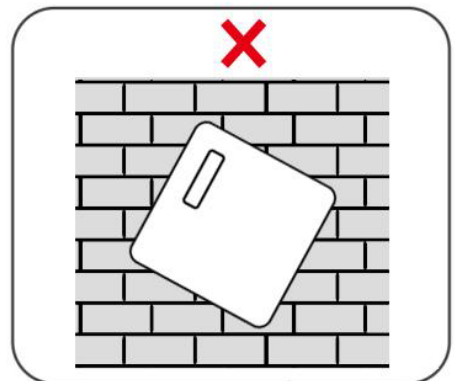
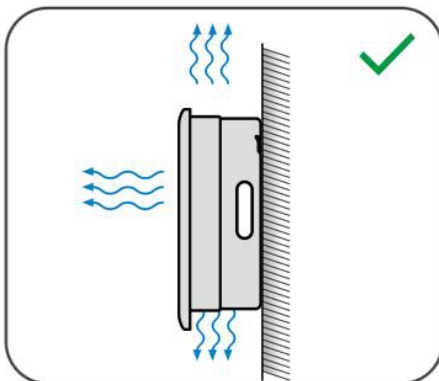
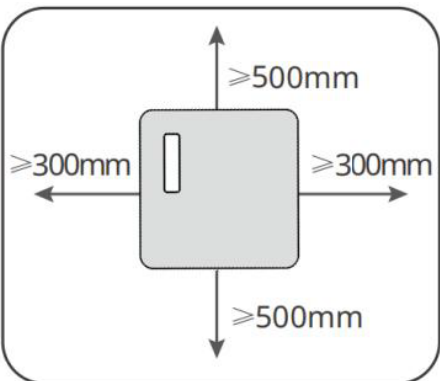
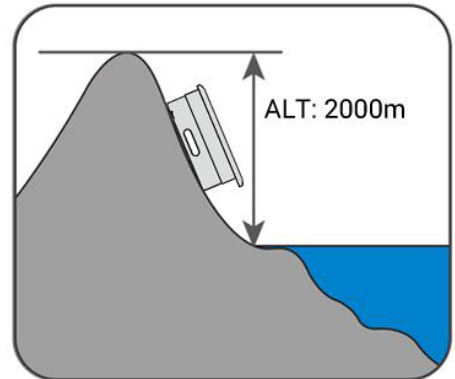
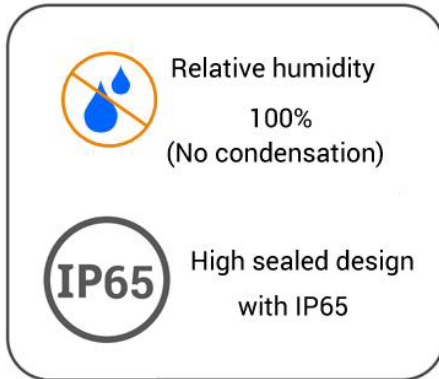
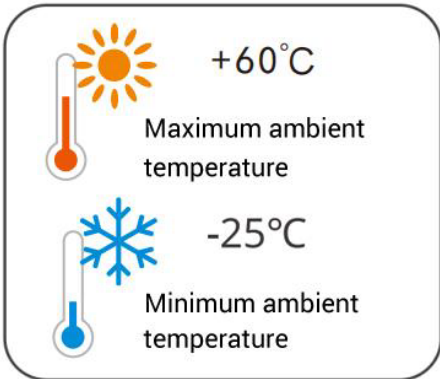
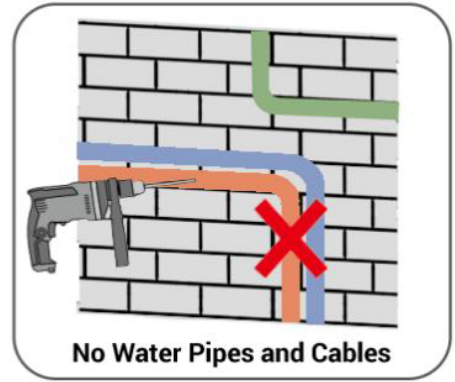

- Install the inverter vertically or at a maximum back tilt of 15 degrees.
- Do not install the inverter upside down, forward tilt, back forward tilt, or horizontally.

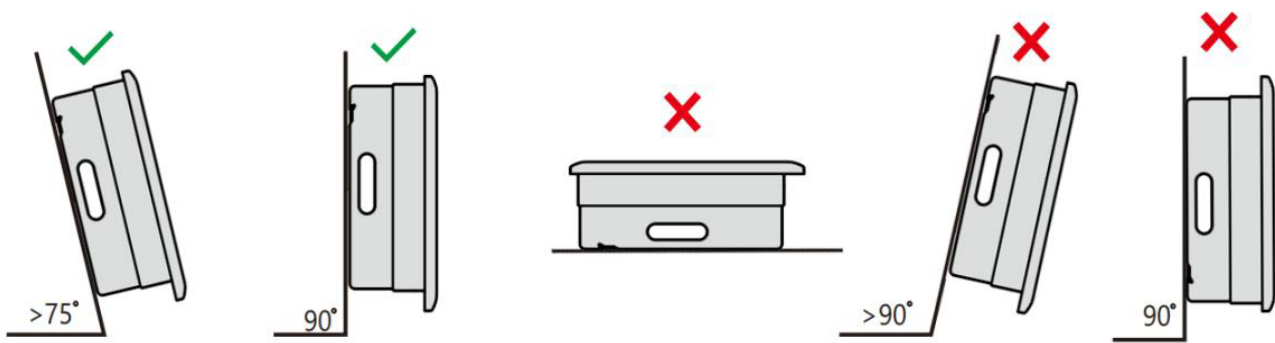

Installation Tool Requirements

The following tools are recommended when installing the equipment. Use other auxiliary tools on site if necessary.

 Goggles	 Safety shoes	 Safety gloves	 Dust mask	 DC terminal crimping tool
 Diagonal pliers	 Wire stripper	 Hammer drill	 Heat gun	 DC wiring wrench
 Marker	 Level	 Heat shrink tube	 Rubber hammer	 Vacuum cleaner
 Multimeter	 Cable tie	 Torque wrench		

5.2 Inverter Installation

5.2.1 Moving the Inverter

CAUTION

- The unit is heavy. Do not lift it alone. During lifting procedures ensure that the unit is firmly secured to avoid the risk of accidental tipping or dropping. Parts serving for support or immobilization of unit shall be designed and manufactured so as to minimize the risk of physical injuries and of accidental loosening of fixing. Ensure that the method of lifting will not allow the unit to slip from chains and slings or turn-over or slide from lifting devices.
- Transportation must be carried by specialized person (truck operators, Hook-up personal), equipped with the necessary protection equipment (overalls, safe shoes, protective gloves, helmets, goggles)
- Do not walk or stand beneath or in the proximity of the load. Avoid sudden movements and jolts when unloading and positioning the unit. Internal handling procedures must be conducted with care.
- Do not exert leverage on the components of the machine. If the unit is not balanced apply ballast. Any protruding parts should not be supported by hand. The inverter should be installed so that the operating panel shall be easily accessible- easy access to the electrical power connection point.
- Accessible for maintenance and repair work. Parts serving for support or immobilization of unit shall be designed and manufactured so as to minimize the risk of physical injuries and accidental loosening of fixings.
- Loading capacity and hardness of the supporting surface, load rating of mounting bracket should be at least four times the weight of the devices according to IEC62109-1. And supporting characteristics will be impaired by wear, corrosion, material fatigue or ageing, This should be calculated by inspection of the design data of supporting material and consulting construction engineer.

5.2.2 Installing Steps

NOTICE

- Avoid the water pipes and cables buried in the wall when drilling holes.
- Wear goggles and a dust mask to prevent the dust from being inhaled or contacting eyes when drilling holes.
- The DC switch lock of appropriate size should be prepared by customers. Diameter of the lock hole is ϕ 8mm (0.31in). Choose the appropriate size. Otherwise, it might not be able to install. (Supported by hybrid inverter only.)
- Make sure the inverter is firmly installed in case of falling down.

Step 1 : Put the mounting plate on the wall or the support horizontally and mark positions for drilling holes.

Step 2 : Drill holes to a depth of 80mm using the hammer drill. The diameter of the drill bit should be 10mm.

Step 3 : Secure the mounting plate using the expansion bolts.

Step 4 : Install the inverter on the mounting plate.

Step 5: Make sure the pin hook the inverter

Step 6 : Install the screw to lock it tight.

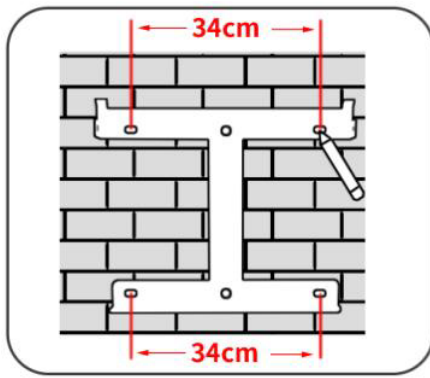

Step 1

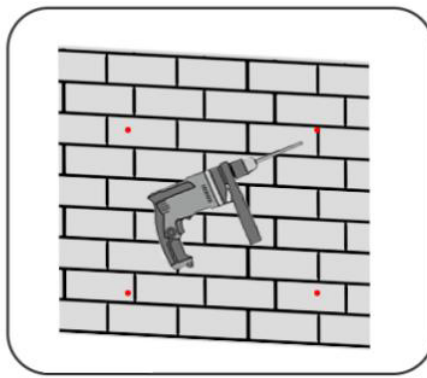

Step 2

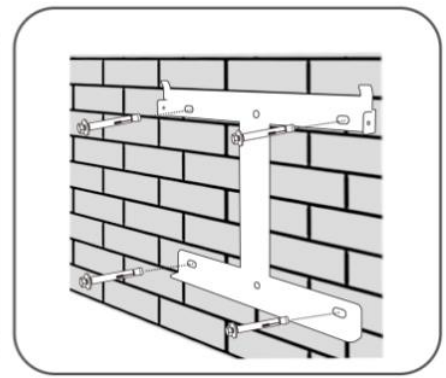

Step 3

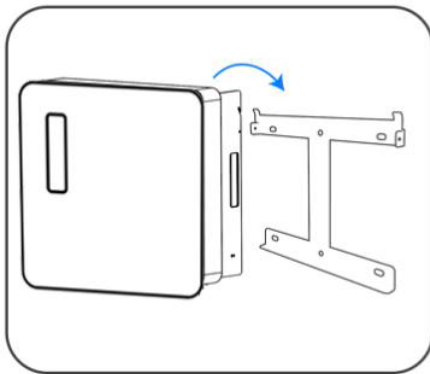

Step 4

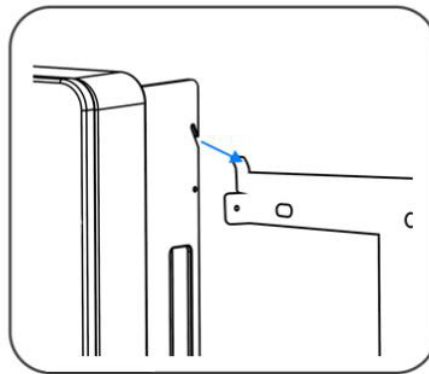

Step 5

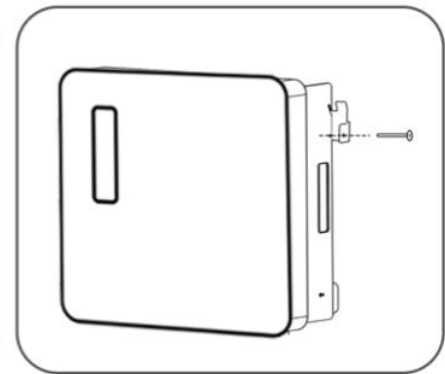

Step 6

6. Electrical Connection





6.1 Safety Precaution

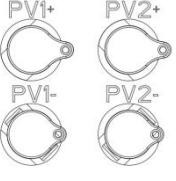

- All operations, cables and parts specification during the electrical connection shall be in compliance with local laws and regulations.
- Disconnect the DC switch and the AC output switch of the inverter to power off the inverter at least 5 minutes for the capacitor to be electrically discharged before any electrical connections. Do not work with power on. Otherwise, an electric shock may occur.
- Tie the same type cables together, and place them separately from cables of different types. Do not place the cables entangled or crossed.
- If the cable bears too much tension, the connection may be poor. Reserve a certain length of the cable before connecting it to the inverter cable port.
- When crimping the terminals, ensure that the conductor part of the cable is in full contact with the terminals. Do not crimp the cable jacket with the terminal. Otherwise the inverter may not operate, or its terminal block getting damaged due to heating and other phenomenon because of unreliable connection after operation.

- Wear personal protective equipment like safety shoes, safety gloves, and insulating gloves during electrical connections.
- All electrical connections should be performed by qualified professionals.
- Cable colors in this document are for reference only. The cable specifications shall meet local laws and regulations.

6.2 Connection Port Description

Connector	Description		Recommend cable type	Recommended Cable specifications
	+: Connect the positive electrode of photovoltaic cell		Industry common outdoor Photovoltaic cable	Conductor cross-sectional area: 4mm ²
	-: Connect the negative electrode of photovoltaic cell			
	+: Connect the positive electrode of lithium battery		Outdoor multi-core copper cable	Conductor cross-sectional area: 6mm ²
	-: Connect the negative electrode of			
	EPS(Load)	L	Outdoor multi-core copper cable	Conductor cross-sectional area: 4mm ²
		N		
		PE		
	Grid(AC)	L	Outdoor multi-core copper cable	Conductor cross-sectional area: 10mm ²
		N		
		PE		

6.3 PE Cable Connection

WARNING

- The PE cable connected to the enclosure of the inverter cannot replace the PE cable connected to the AC output port. Both of the two PE cables must be securely connected
- Make sure that all the grounding points on the enclosures are equipotential connected when there are multiple inverters.
- To improve the corrosion resistance of the terminal, it is recommended to apply silica gel or paint on the ground terminal after installing the PE cable.
- Prepare PE cables with the recommended specification:
 - Type: Outdoor single-core copper wire
 - Cross-sectional area: 10mm²

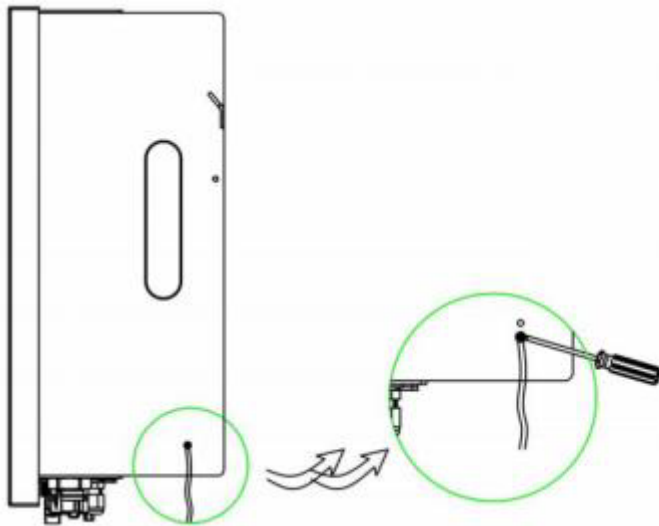
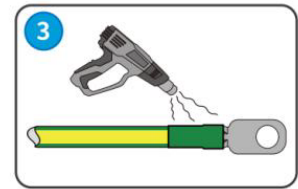
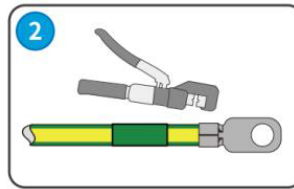
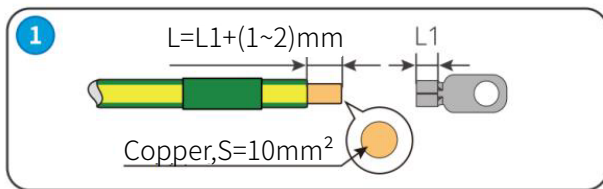

6.4 Grid Connection

NOTICE

SSE[™]HH3K-6K[™]P1 series inverters are designed for single-phase grid. Voltage range is 220/230/240V; frequency is 50/60Hz. Other technical requests should comply with the requirement of the local public grid.

WARNING

- A micro-breaker for max output over current protection device shall be installed between inverter and grid, and the current of the protection device is referred to the table above, any load SHOULD NOT be connected with the inverter directly.

NOTICE

Check the grid voltage and compare with the permitted voltage range (refer to technical data).

- Disconnect the circuit-breaker from all the phases and secure against re-connection.
- Trim the wires:
 - Trim all the wires to 52.5mm and the PE wire to 55mm.
 - Use the crimping pliers to trim 12mm of insulation from all wire ends as below.
 - Please refer to local cable type and color for actual installation.

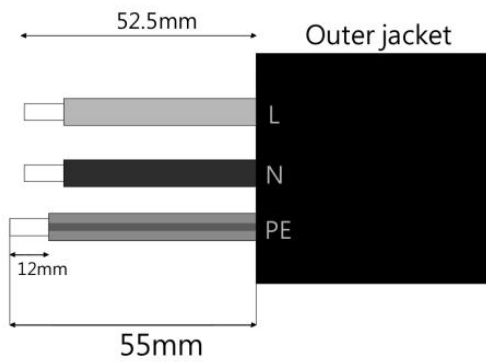

L: Brown/Red Wire
 N: Blue/Black Wire
 PE: Yellow & Green Wire

GRID Wiring

	<ul style="list-style-type: none"> • Turn off the DC and battery switch . • Choose 10mm² wire to connect the Grid port. • Trim 12mm of insulation from the wire end.
<p>Separate the GRID plug into three parts as below.</p> <ul style="list-style-type: none"> - Hold middle part of the female insert, rotate the back shell to loosen it, detach it from female inset. - Remove the cable nut (with rubber insert) from the back shell. 	
	<p>Slide the cable nut and then the back shell onto the cable. Install the cable into the plug terminal and lock the screw, torque is (2.0+/-0.2 N.m).</p>
<p>Push the threaded sleeve into the socket, tighten up the cap on the terminal.</p>	
	<p>Push the threaded sleeve to connection terminal until both are locked tightly on the inverter.</p>

Remove the AC connector: Press the bayonet out of the slot with a small screwdriver or the unlock tool and pull it out, or unscrew the threaded sleeve, then pull it out.

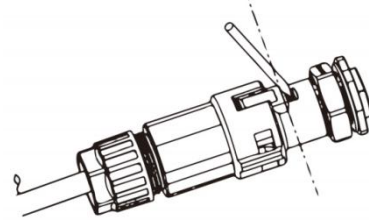

6.5 EPS Connection

NOTICE

Check the grid voltage and compare with the permitted voltage range (refer to technical data).

- Disconnect the circuit-breaker from all the phases and secure against re-connection.
- Trim the wires:
 - Trim all the wires to 20mm and the PE wire to 23mm.
 - Use the crimping pliers to trim 10mm of insulation from all wire ends as below.
 - Please refer to local cable type and color for actual installation.

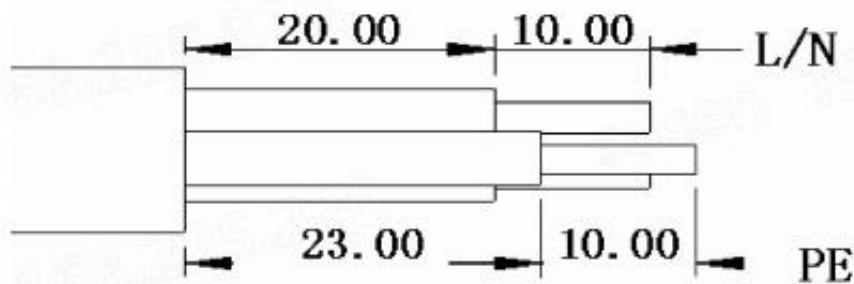

EPS Wiring

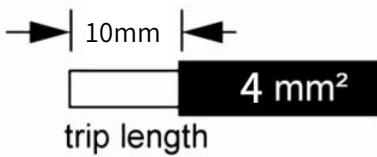

- Turn off the DC and battery switch .
- Choose 4mm² wire to connect the EPS port.
- Trim 10mm of insulation from the wire end.

Set the parts on the cable, Insert the terminal holes in sequence.

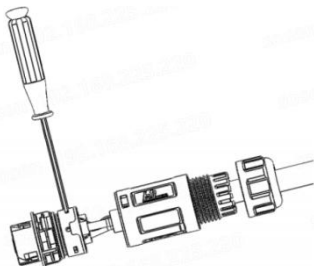
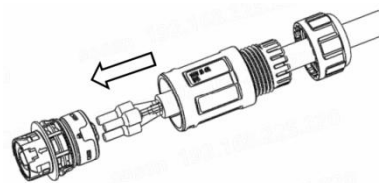

Crimp the wire with an inner hexagon screwdriver and screw the torque 1.2+/-0.1N.m.

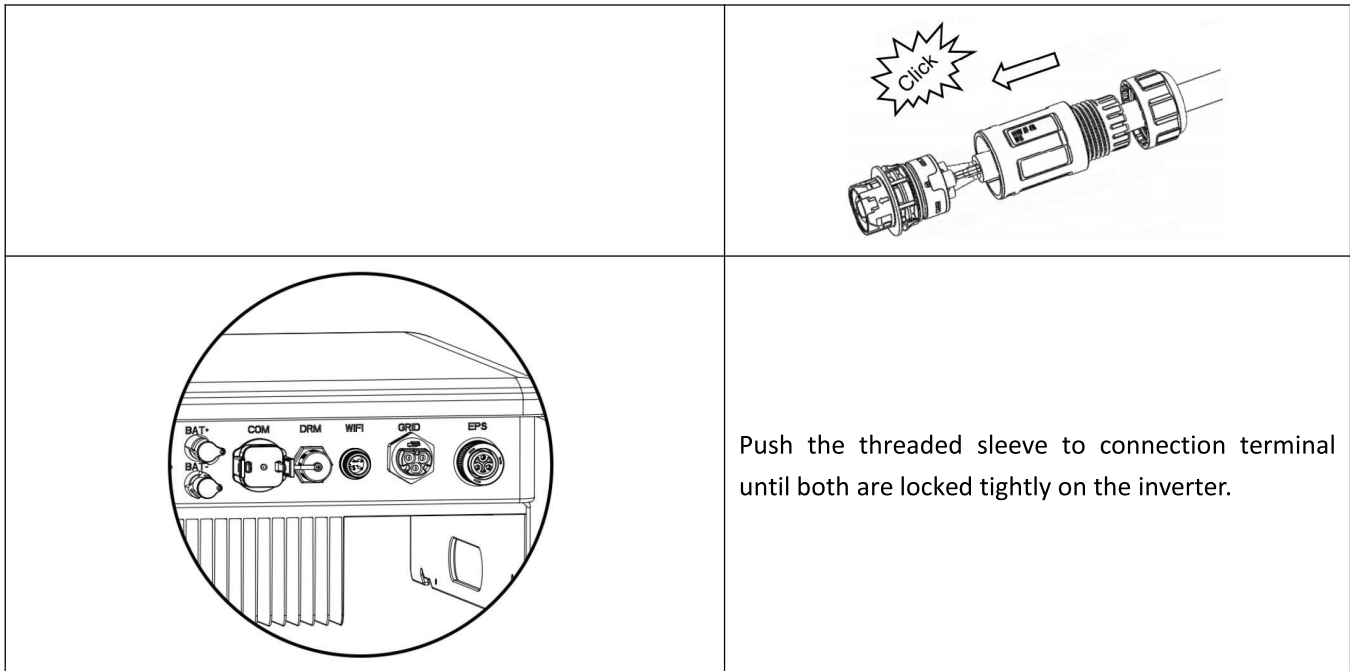

6.6 PV Connection

6.6 .1 PV String Connection

⚠ DANGER

Confirm the following information before connecting the PV string to the inverter. Otherwise, the inverter may be damaged permanently or even cause fire and cause personal and property losses.

1. Make sure that the max short circuit current and the max input voltage per MPPT are within the permissible range.
2. Make sure that the positive pole of the PV string connects to the PV+ of the inverter. And the negative pole of the PV string connects to the PV- of the inverter.

⚠ WARNING

- 1-Please choose a suitable external DC switch if the inverter does not have a built-in DC switch.
- 2-PV module voltage is very high and within a dangerous voltage range, please comply with the electric safety rules when connecting
- 3-Please do not make PV positive or negative to ground.
- 4-PV modules: Please ensure they are the same type, have the same output and specifications, are aligned identically, and are tilted to the same angle. In order to save cable and reduce DC loss, we recommend installing the inverter as near to the PV modules as possible.

💡 NOTICE

The DC input cable is prepared by the customer. Recommended specifications:

- Type: the outdoor photovoltaic cable that meets the maximum input voltage of the inverter.
- Conductor cross-sectional area: 4mm².



PV connection mode below is NOT allowed!

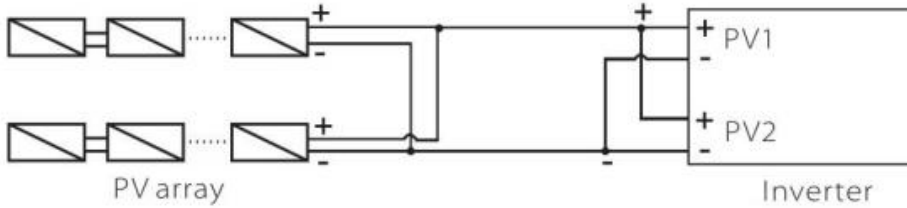

PV connection mode below is allowed!

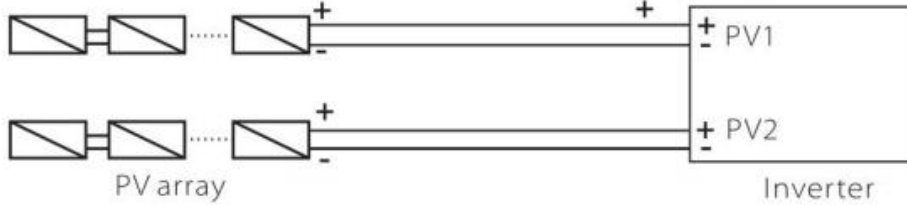

6.6 .2 PV Wiring

<ul style="list-style-type: none"> • Turn off the PV and battery switch . • Choose 4mm² wire to connect the PV module. • Trim 6mm of insulation from the wire end. 	<p>6.0mm</p> <p>4 mm²</p> <p>strip length</p>
<p>Plug Pin contact cable nut</p> <p>D- D+</p>	<p>Separate the DC connector (PV) as below.</p>
<ul style="list-style-type: none"> • Insert striped cable into pin contact and ensure all conductor strands are captured in the pin contact. • Crimp pin contact by using a crimping plier. Put the pin contact with striped cable into the corresponding crimping pliers and crimp the contact. 	
	<p>Insert pin contact through the cable nut to assemble into back of the male or female plug. When you feel or hear a “click” the pin contact assembly is seated correctly.</p>
<p>Unlock the DC connector</p> <ul style="list-style-type: none"> - Use the specified wrench tool. - When separating the PV + connector, push the tool down from the top. - When separating the PV - connector, push the tool down from the bottom. - Separate the connectors by hand. 	

6.7 Battery Connection





- The battery used with the inverter shall be approved by the inverter manufacturer. The approved battery list can be obtained through the official website.
- A short circuit in the battery may cause personal injury. The instantaneous high current caused by a short circuit can release a large amount of energy and may cause a fire.
- Before connecting the battery cable, ensure the inverter and the battery, and downstream&upstream switches, are all disconnected.
- It is forbidden to connect and disconnect the battery cables when the inverter is running. Otherwise it may cause electric shock.
- Do not connect one battery pack to more than one inverter at the same time. Otherwise, it may cause damage to the inverter.
- It is forbidden to connect loads between the inverter and batteries.
- When connecting battery cables, use insulated tools to prevent accidental electric shock or short circuit to the batteries.
- Ensure that the open circuit voltage of the battery is within the permissible range of the inverter.
- Install a DC switch between the inverter and the battery.



- Connect the battery cables to the corresponding terminals such BAT+, BAT- and grounding ports correctly. Otherwise it will cause damage to the inverter.
- Ensure that the whole cable cores are inserted into the terminal holes. No part of the cable core can be exposed.
- Ensure that the cables are connected securely. Otherwise it will cause damage to the inverter due to overheat during its operation.
- Servicing of batteries should be performed or supervised by personnel knowledgeable about batteries and the required precautions.
- When replacing batteries, replace with the same type and number of batteries or battery packs.
- CAUTION: Do not dispose of batteries in a fire. The batteries may explode.
- CAUTION: Do not open or damage batteries. Released electrolyte is harmful to the skin and eyes. It may be toxic.
- CAUTION: A battery can present a risk of electrical shock and high short-circuit current. The following precautions should be observed when working on batteries:
 - a) Remove watches, rings, or other metal objects.
 - b) Use tools with insulated handles.
 - c) Wear rubber gloves and boots.
 - d) Do not lay tools or metal parts on top of batteries.
 - e) Disconnect charging source prior to connecting or disconnecting battery terminals.
 - f) Determine if battery is inadvertently grounded. If inadvertently grounded, remove source from ground. Contact with any part of a grounded battery can result in electrical shock. The likelihood of such shock can be reduced if such grounds are removed during installation and maintenance (applicable to equipment and remote battery supplies not having a grounded supply circuit)

Connection steps:

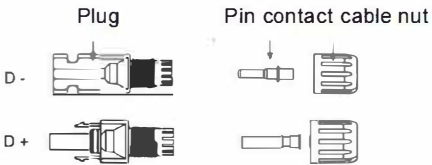
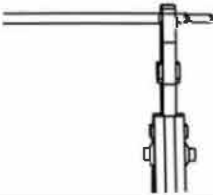
<ul style="list-style-type: none"> • Turn off the PV and battery switch . • Choose 6mm² wire to connect the battery. • Trim 6mm of insulation from the wire end. 	
--	--

	<p>Separate the DC connector (Battery) as below.</p>
<ul style="list-style-type: none"> • Insert striped cable into pin contact and ensure all conductor strands are captured in the pin contact. • Crimp pin contact by using a crimping plier. Put the pin contact with striped cable into the corresponding crimping pliers and crimp the contact. 	
	<p>Insert pin contact through the cable nut to assemble into back of the male or female plug. When you feel or hear a “click” the pin contact assembly is seated correctly.</p>
<p>Unlock the DC connector</p> <ul style="list-style-type: none"> - Use the specified wrench tool. - When separating the BAT + connector, push the tool down from the top. - When separating the BAT - connector, push the tool down from the bottom. - Separate the connectors by hand. 	

6.8 Communication Device Installation (Optional)

NOTICE

The SSE-HH3K-6K-P1-EU series inverter are available with multiple communication options such as WiFi, Bluetooth, RS485 and Meter with an external device.

Operating information like output voltage, current, frequency, fault information, etc., can be monitored locally or remotely and cellphone App via these interfaces.

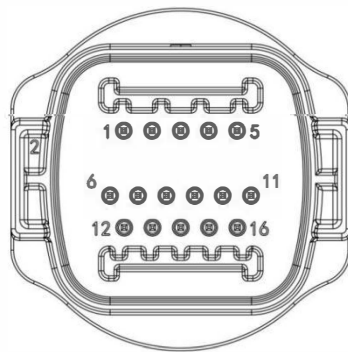

PIN	1	2	3	4	5	6	7	8
Definition	NC	NC	BMS CANH	BMS CANL	NC	NC	METER 485A	METER 485B
PIN	9	10	11	12	13	14	15	16
Definition	EMS 485A	EMS 485B	GND_COM	NC	PARA1_CANH	PARA1_CANL	PARA2_CANH	PARA2_CANL

6.8.1 EMS RS485 Connection

RS485 is a standard communication interface which can transmit the real time data from inverter to PC or other monitoring devices. (COM:PIN9-EMS485A,PIN10-EMS485B)

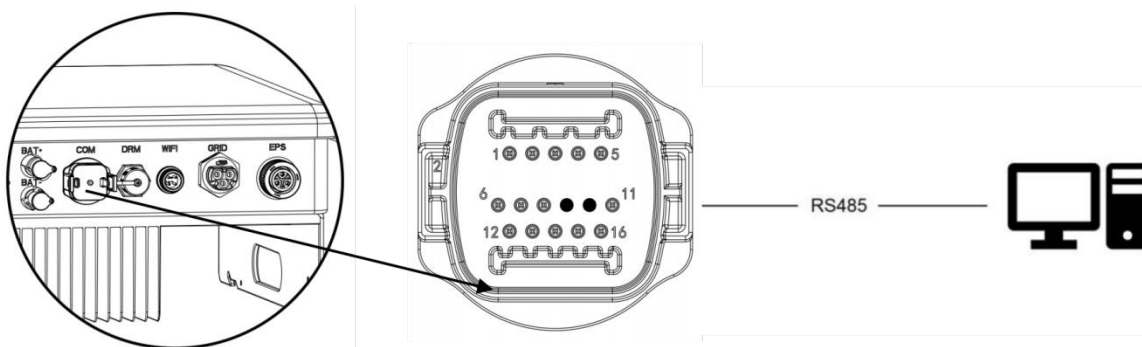

6.8.2 BMS CAN Communication PIN Definition

Communication interface between inverter and battery is CAN with a RJ45connector. (COM:PIN3-BMS CANH,PIN4-BMS CANL)

BYD battery connection for example.

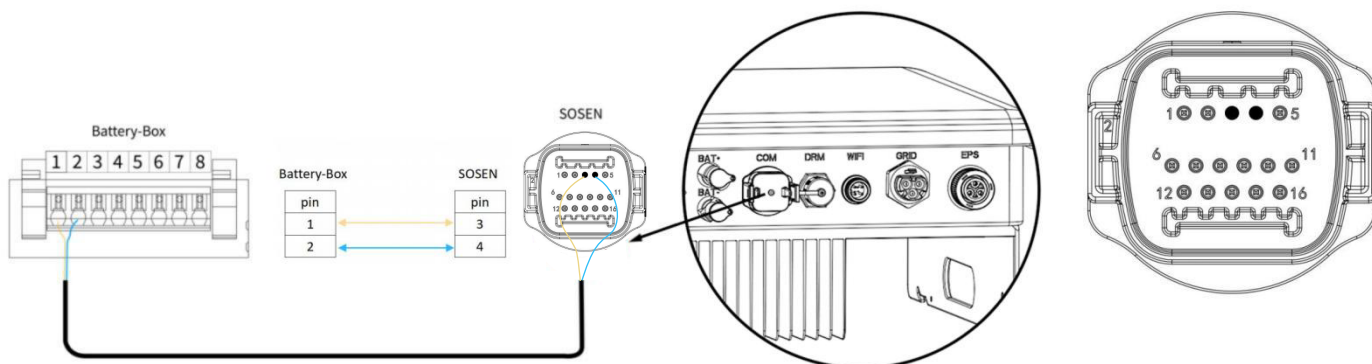

6.8.3 Meter

The inverter has integrated export limitation functionality. To use this function, a power meter must be installed. For Meter installation, please install it on the grid side.

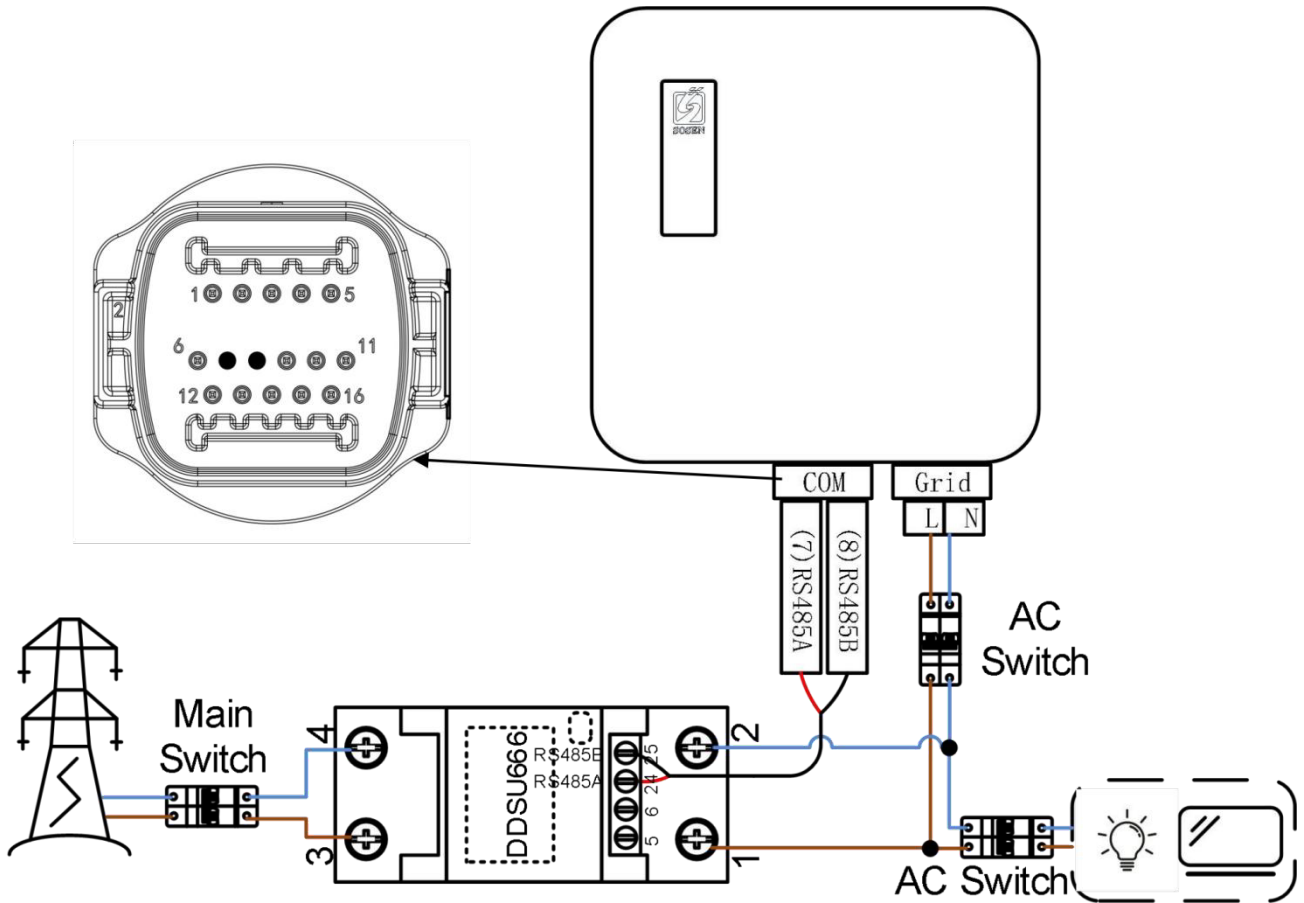

6.9 .Wi-Fi&BLE stick installation

6.9.1 Indication

A: Circular Connector Interface: Connect to inverter and communication

B: Red LED: Inverter communication indication

C: Green LED: Network communication indication

D: Product label: Show product information

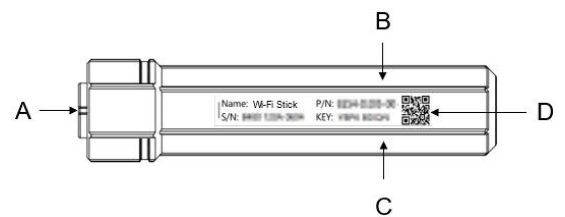

1. LED glow only when the Wi-Fi&BLE stick is powered on.
2. When the Wi-Fi&BLE stick is powered on, the green LED glows for 3S as a power on indication.
3. The more detail LED indication please refer chapter 9 “LED indication and trouble shooting”.

6.9.2 Install the Wi-Fi&BLE stick

Follow the installation steps!

1. Remove the waterproof cover.	2. Aligning groove.
3. Plug in WiFi module.	4. Revolve to lock the WiFi module.

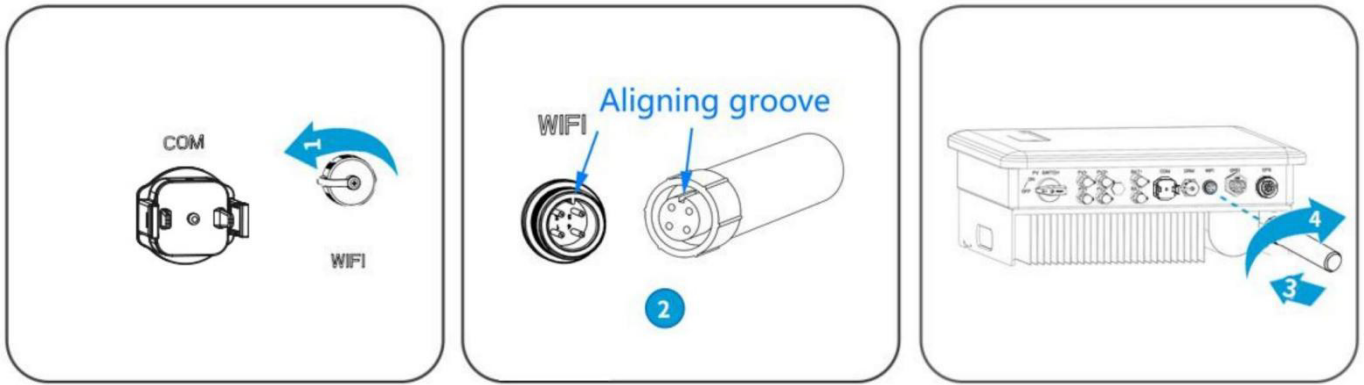

6.9.3 Web/APP

Item	Web View	APP	SOSEN Energy Web&APP manual
QR Code 			
Website	https://sosen.inteless.com/	iOS: search "SOSEN Energy" in Apple Store Android: search "SOSEN Energy" in Google Play	https://www.sosencx.com/download.html

6.9.4 Wi-Fi Connection

The Wi-Fi connection diagram of Wi-Fi&BLE stick is shown in the figure below. The specific process can be downloaded the APP, and configure the network connection according to the operation guide of the APP.



6.9.5 Installation qualification

If the Wi-Fi&BLE stick works normally, red LED and green LED are always glowing. Otherwise, it needs to be corrected by referring to chapter 9 "LED indication and trouble shooting"

6.9.6 LED indication and trouble shooting

	Red LED: Inverter communication indication		Green LED: Network communication indication
---	--	---	---

LED	State	Indication
	Cycle for 2S: flash once quickly, then glowing	Communication abnormality: Check the connection between the WIFI stick and the inverter please
	Not glow more than 20S	The power supply to the Wi-Fi&BLE stick is abnormal or damaged: 1. Check whether the power supply of the Aerial Plug Interface on the inverter is normal 2. Wi-Fi&BLE stick abnormal, contact the dealer
	Cycle for 2S: flash once quickly, then off	Communication failure: Check whether the connection between the Wi-Fi&BLE stick and inverter is loose or poor contact
	When powered on, continuously glows 3S, and then off	Power on indication
	Glow more than 5S	Communication is normal
	During the long glowing, flash occasionally	Network transmit data
	Cycle for 20S: flash once quickly, then off	The route is not connected: 1. Check whether the password is right 2. Check the strength of the router
	Cycle for 20S: flash 3 times continuously, then off	Connect to the route, but can't connect to the cloud server: 1. Check whether the router has Internet access permission 2. Check the firewall setting
	Cycle for 20S: flash 4 times continuously, then off	Wi-Fi&BLE stick information error: Please contact the dealer

6.10 DRM Connection

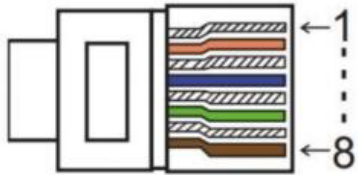
	PIN	1	2	3	4	5	6	7	8
	Definition	DRM 1/5	DRM 2/6	DRM 3/7	DRM 4/8	REF GEN/0	COM LOAD/0	V+	V-

7.Operation

7.1 Indicator panel

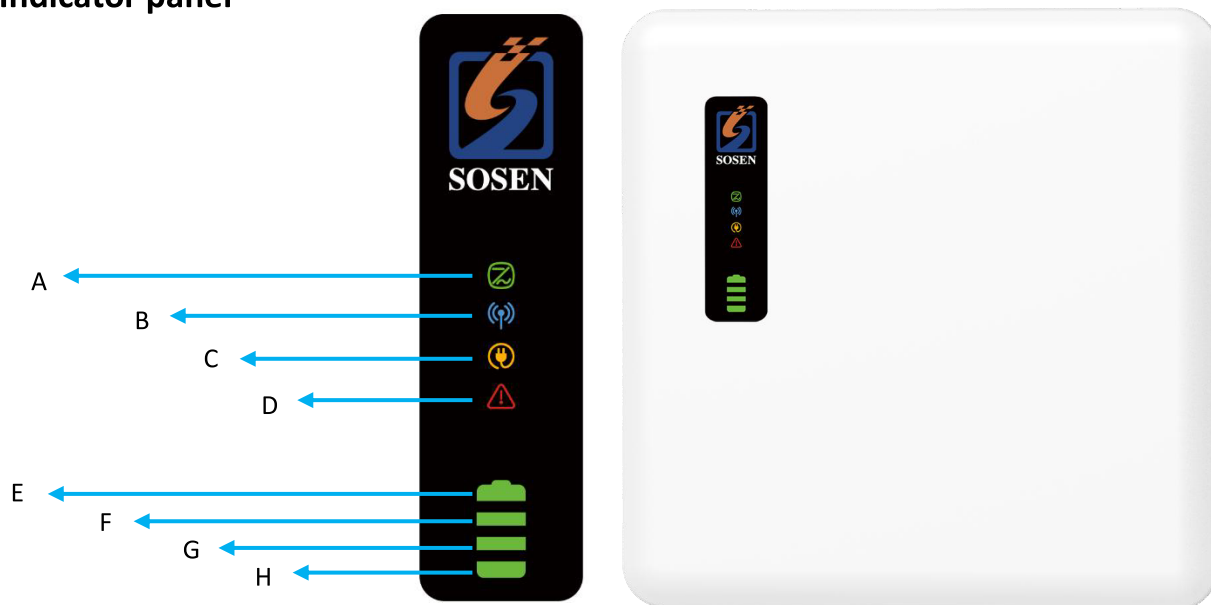

Name	Object	Function
Indicator LED	A	Green : ON, The inverter is running ; Flash is Standby.
	B	Blue : ON, Communication with BMS normal.
	C	Yellow : ON, The inverter is in EPS mode.
	D	Red : The inverter is in fault mode.
	E	Green : ON , battery capacity is 90~100%.
	F	Green : ON , battery capacity is 61~89%.
	G	Green : ON , battery capacity is 35~60%.
	H	Green : ON , battery capacity is 10~34%.

8.Trouble Shooting

This section contains information and procedures for solving possible problems with the SSE-HH3K-6K-P1-EU/AU series inverters, and provides you with trouble shooting tips to identify and solve most problems that could occur with the SSE-HH3K-6K-P1-EU/AU series inverters.

This section will help you narrow down the source of any problems you may encounter. Please read the following trouble' shooting steps.

Check the warning or fault messages on the System Control Panel or Fault codes on the inverter information panel. If a message is displayed, record it before doing anything further. Attempt the solution indicated in below table.

Fault Code	Solution
	1.1 Applicable Model
Grid Lost Fault	Grid is lost. System will reconnect if the utility is back to normal Or seek help from us, if not go back to normal state.
Grid Volt Fault	Grid voltage out of range. System will reconnect if the utility is back to normal Or seek help from us, if not go back to normal state.
Grid Freq Fault	Grid frequency out of range. System will reconnect if the utility is back to normal Or seek help from us, if not go back to normal state.
PV Volt Fault	PV voltage out of range. Please check the output voltage of PV panels Or seek for help from us.
HW Bus Vol Fault	Bus voltage out of range detected by hardware Disconnect PV grid and battery, then reconnect Or seek help from us, if not go back to normal state.
Bat Volt Fault	Battery voltage fault. Check if the battery input voltage is within the normal range Or seek help from us.
10 min Volt Fault	The grid voltage is out of range for the last 10 Minutes. System will reconnect if the utility is back to normal. Or seek help from us, if not go back to normal state.
DCI Fault	DC component is out of limit in output current. Disconnect PV, grid and battery, then reconnect. Or seek help from us, if not go back to normal state.
EPS DcV Fault	DC component is out of limit in output voltage. Disconnect PV, grid and battery, then reconnect Or seek help from us, if not go back to normal state.
SW Inv Cur Fault	Output current high detected by software. Disconnect PV, grid and battery, then reconnect Or seek help from us, if not go back to normal state.
Res Cur Fault	The residual current is high. Please check if the insulation of electric wires is damaged. Wait for a while to check if back to normal Or seek for help from us.
ISO Fault	The isolation is failed. Please check if the insulation of electric wires Wait for a while to check if back to normal Or seek for help from us.
Temp Fault	The inverter temperature is high. Please check if the environment temperature. Wait for a while to check if back to normal Or seek for help from us.
BatCon Dir Fault	The battery connection is reversed. Check if the positive pole and negative pole of battery are correctly connected Or seek help from us.
Consist Fault	The sample value between master and slave is not consistent. Disconnect PV, grid and battery, then reconnect. Or seek help from us, if not go back to normal state.

Fault Code	Solution
Bat Low Fault	The battery power is low. Wait the battery to be recharged . Or seek for help from us.
ByPass Relay Fault	By pass relay fault Disconnect PV, grid and battery, then reconnect. Or seek help from us, if not go back to normal state.
SPI Fault	The communication between master and slave fault Disconnect solar power PV. Or seek help from us, if cannot go back to normal state.
BMS Lost	The communication between BMS and inverter is interrupted. Check if the communication cable between BMS and inverter is correctly and well connected.
Inv EEPROM Fault	The master EEPROM is fault. Disconnect PY, grid and battery, then reconnect. Or seek help from us, if not go back to normal state.
Res Cur HW Fault	The residual current circuit is fault.

	Please check if the insulation of electric wires is damaged. Wait for a while to check if back to normal.Or seek for help from us.
EPS Relay Fault	The EPS relay always keep open. Disconnect PV, grid and battery, then reconnect. Or seek help from us, if not go back to normal state.
Grid Relay Fault	The grid relay always keep close. Disconnect PV, grid and battery, then reconnect. Or seek help from us, if not go back to normal state.
Meter Lost Fault	The communication between meter and inverter is interrupted. Check if the communication cable between meter and Inverter is correctly and well connected.
SCI Fault	SCI communication fault Disconnect solar power PV+ , PV- and battery, reconnect them. Or seek help from us, if cannot go back to normal state.
BMS Int Fault	BMS internal communication fault. Disconnect battery, check wiring between inverter and battery , battery internal wiring then reconnect. Or seek help from us, if not go back to normal state.
BMS Relay Fault	The battery relay is fault. Disconnect battery, then reconnect. Or seek help from us, if not go back to normal state.
Bat Volt High	Battery over voltage protect. Wait for5 minutes., check again. Or seek help from us, if not go back to normal state.
Bat Voltage Low	Battery under voltage protect. Wait for5 minutes, check again. Or seek help from us, if not go back to normal state.
BMS ChgCur High	Battery over current charging protect. Wait for5 minutes., check again. Or seek help from us, if not go back to normal state.
BMS DchgCur High	Battery over current discharging protect. Wait for5 minutes,, check again. Or seek help from us, if not go back to normal state.
BMS Temp High	Battery temperature is high. Wait for5 minutes, check again. Or seek help from us, if not go back to normal state.
BMS Temp Low	Battery temperature is low. Wait for5 minutes., check again. Or seek help from us, if not go back to normal state.
EPS Over Load	Over load in off grid mode. Please check if the EPS load power exceeds the limit. Or seek for help from us.
PV Config Fault	PV Connection Setting Fault Resetting the PV connection Or seek help from us, if cannot go back to normal state.



NOTICE

If your inverters information panel is not displaying a Fault light, check the following list to make sure that the present state of the installation allows proper operation of the unit.

Is the inverter located in a clean, dry, and adequately ventilated place?

Have the DC input breakers been opened?

Are the cables adequately sized and short enough?

Are the input and output connections and wiring in good condition?

Are the configurations settings correct for your particular installation?

Are the display panel and the communications cable properly connected and undamaged?

Contact SOSEN INNOVATION Customer Service for further assistance. Please be prepared to describe details of your

system installation and provide the model and serial number of the unit.

9. Maintenance

9.1 Power Off the Inverter



- Power off the inverter before operations and maintenance. Otherwise, the inverter may shocks may occur.
- Delayed discharge. Wait until the components are discharged after power off.

Step 1: Turn off the AC breaker on the ON-GRID side of the inverter.

Step 2: Turn off the AC breaker on the BACK-UP side of the inverter.

Step 3: Turn off the battery breaker between the inverter and the battery.

Step 4: Turn off the PV switch of the inverter.

9.2 Removing the Inverter



- Make sure that the inverter is powered off.
- Wear proper PPE before any operations.

Step 1: Disconnect all the cables, including DC cables, AC cables, communication cables, the communication module, and PE cables.

Step 2: Remove the inverter from the mounting plate.

Step 3: Remove the mounting plate.

Step 4: Store the inverter properly. If the inverter needs to be used later, ensure that the storage conditions meet the requirements.

9.3 Disposing of the Inverter

If the inverter cannot work anymore, dispose of it according to the local disposal requirements,

The inverter cannot be disposed of together with household waste.



- Make sure that the inverter is powered off.
- Wear proper PPE before any operations.

9.4 Routine Maintenance

Maintaining Item	Maintaining Method	Maintaining Period
System Clean	Check the heat sink, air intake, and air outlet for foreign matter or dust.	Once 6-12 months
PV Switch	Turn the DC switch on and off ten consecutive times to make sure that it is working properly.	Once a year
Electrical Connection	Check whether the cables are securely connected. Check whether the cables are broken or whether there is any exposed copper core.	Once 6-12 months
Sealing	Check whether all the terminals and ports are properly sealed. Reseal the cable hole if it is not sealed or too big.	Once a year