



解放双手 因我而变 智慧工厂 为您而来
 No quality No future Customer first Service first

一言九鼎 为您用心



电子画册



公众号



360°全景图

星鼎江包装机械制造(昆山)有限公司
 上海鼎江包装机械制造有限公司

地址: 江苏省昆山市周市镇金茂路777号
 电话: 021-69575668 69577995
 传真: 021-39545568
 手机: 13661813068 13764550916
 网址: www.dj-pack.com www.shdingjiang.com.cn dingjiang.en.alibaba.com
 邮箱: jolin@dj-pack.com jolin@shdingjiang.com.cn

Xingdingjiang Packaging machinery Manufacturing Co., Ltd.
 Shanghai Dingjiang Packaging machinery Manufacturing Co., Ltd.
 Address: 777 Jinmao Road, Zhoushi Town, Kunshan City, Jiangsu, China (Mainland)
 Tel: +86-21-69575668 69577995
 Fax: +86-21-39545568
 Mob: +86-13764550916 +86-15821413612
 Web: www.dj-pack.com www.shdingjiang.com.cn dingjiang.en.alibaba.com
 Email: jolin@dj-pack.com jolin@shdingjiang.com.cn



前进
 是一种自我超越
 需要异于寻常的勇气
 不断向前跨越
 臻至完美



20 Years Experience Factory Granule Powder Packaging All Line Solution Supplier

星鼎江包装机械制造(昆山)有限公司
上海鼎江包装机械制造有限公司
 Xingdingjiang Packaging machinery Manufacturing Co., Ltd.
 Shanghai Dingjiang Packaging machinery Manufacturing Co., Ltd.

关于我们

上海鼎江包装机械制造有限公司是集研发 生产 销售于一体，主营颗粒粉剂包装机及流水线的专业企业。经过十几年的发展，凭着对先进技术的不断探索研究和应用，使我司产品不断升级更新，我司产品已通过CE、TUV、ISO认证，并获得多项专利。

目前我司产品已广泛应用于奶粉、食品、保健品、调味品、食品配料、碳罐、化工等各个领域，产品畅销全国并远销澳大利亚、法国、德国、波兰、新西兰、俄罗斯、墨西哥、黎巴嫩、埃及、印度、马来西亚、菲律宾等三十多个国家地区。近年来，我公司已经为国内外众多的乳品、保健品和调味品企业提供了奶粉和鸡粉罐装、袋装生产线，深受广大客户好评。

鼎江秉承精工制造，一言九鼎的理念，用心为客户设计合理的方案，提供优质的产品，一旦承诺，终身相随的售后，使您选择我们，选择无忧。

以下为部分合作厂商

您的信赖与帮助成就了今天的鼎江，鼎江人将一如既往地秉承“创新、优质、诚信”的理念，以优质的产品和优良的服务回报您。



我们的产品渗透在社会的各行各业，默默改变着我们的工作和生活。数不胜数的成功用户，是鼎江坚强的后盾。感谢广大用户的厚爱。感谢世界各地的合作伙伴和代理商的支持和帮助。

About Us

Dingjiang Packaging Machinery is a professional supplier of granule powder packaging machines. Our headquarters is located in Shanghai and we supplying industry across the world, our experience in pack machine helps us to improve your productivity by reducing the time wasted on finding the right machine for the job.

- ★ Established in 2008 ,1 hour to hongqiao port ,Economic center of china .
- ★ 20 years experience factory focus on powder /grain packaging that we can Supply you best solution.
- ★ Supply OEM/ODM manufacturing,Help you improve your brand reputation.
- ★ Over 20 engineers striving for Dingjiang,guarantee quality/service.
- ★ Shanghai high-tech enterprises(Less than 1000 companies in the machinery industry got it).
- ★ CE ,TUV ,ISO Certificated also machine with lot patents
- ★ 6-8 exhibitions per year ,Exported to 40 countries .
- ★ Philosophy of no quality,no future .

★ All Sizes, Different type of powder and grain pack machine available including:

- 1、 Auger filler,
- 2、 Powder filling machine,
- 3、 25kg powder grain packaging machine,
- 4、 1kg powder pack machine ,
- 5、 Granule packing machine .
- 6、 Vertical Form Fill Seal Packaging Machines
- 7、 Inclined, Horizontal Screw Feeders & Conveyors
- 8、 Mixing Machines
- 9、 Packing and Palletizing robot

Our Customer



Thank you for your trust and we will offer our best quality and service to you .

企业证书 Our Certificate



目录 Contents

- 半自动粉末包装机
Semi-automatic powder packaging machine1-5
- 全自动粉末袋装机
Automatic powder bag packaging machine6-9
- 全自动粉剂罐装机
Automatic powder bottle filling machine.....10-13
- 半自动颗粒包装机
Semi-automatic granule packaging machine.....14-16
- 全自动颗粒袋装机
Automatic granule bag packaging machine17-20
- 全自动抽真空六面体包装机
Automatic hexahedron vacuum granule packaging machine.....21
- 全自动液体袋装机
Automatic liquid bag packaging machine22-24
- 螺杆充填机
Auger filler.....25
- 螺旋上料机
Inclined screw conveyor.....26
- 混合机
Horizontal mixer.....27
- 全自动听装线配套设备
Automatic can pack system auxiliary equipment28-29
- 其它辅助设备
Other auxiliary equipment.....30-33
- 全自动粉体灌装生产线
Automatic powder bottle filling production line.....34
- 全自动摇摇瓶粉体灌装线
Automatic shake bottle powder filling line.....35-36
- 装箱码垛
Packing and palletizing37-40
- 客户合影
Customer Visit US41
- 我们的展会
Dingjiang in the world.....42

简要说明及特点 Brief instruction

该系列半自动充填包装机按照国家GMP标准而设计。设计成：空气阻尼组合式透明料箱、可回收吸尘装置、升降工作台等。工作参数配方可储存，备用使用，有10个以上预设配方。适用包装粉粒状物料，如奶粉、饲料、米粉、咖啡、味精、固体饮料、葡萄糖、固体医药等。

This semi-automatic filling and packaging machine was designed in accordance with GMP. The hopper is sheer and dust can be collected. And the working table height is adjustable. Over 10 recipes can be saved for later using. The machine is suitable for packaging powdery product, such as milk powder, feed, rice powder, icing sugar coffee, monosodium glutamate, solid beverage, dextrose, solid medicament, etc.

主要特征 Main Features

- 中/英文触摸屏人机界面，PLC控制系统。
- 伺服电机驱动螺旋，称重反馈比重跟踪。
- 侧开门料箱，整机不锈钢制造。
- 该机器料斗属于专利产品。
- Chinese/English is displayed in touch screen. HMI using PLC and touch screen.
- Filling system is driven by servo-motor, higher weighing precision.
- Made of stainless steel totally, the door of hopper can be side opened.
- The hopper has patent right.



DJ-1A3

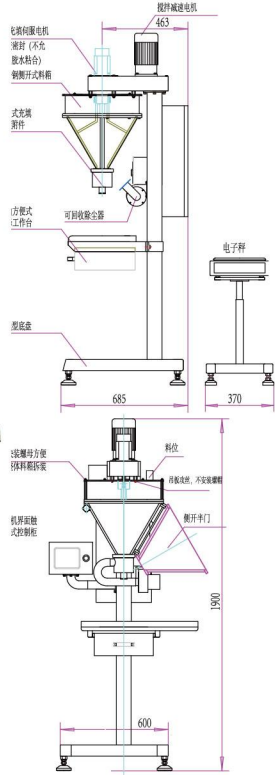

DJ-1B3

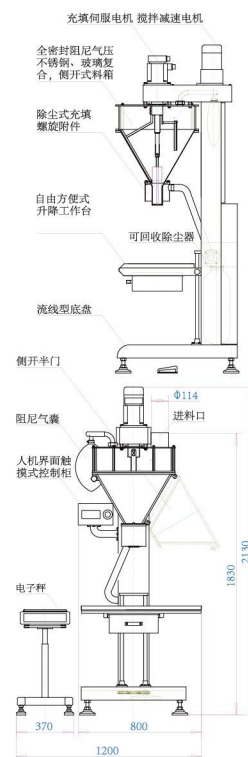

技术参数 Technological parameters

型号 Model	DJ-1A3	DJ-1B3
充填重量 Package Weight	1-500克	10-5000g
称重范围 Weighing Range	0.2-800g(分辨率0.1克)	1-6000g(分辨率1克)
充填精度 Packaging Accuracy	≤±0.3-1%(不同的物料, 此参数有可能变化)	
充填速度 Packaging Speed	15-60包/分	10-45包/分
电 源 Power Supply	380/220V 50-60Hz	
整机功率 Total Power	1KW	1.3KW
整机重量 Total Weight	110kg	150kg
整机体积 Overall Dimensions	800×700×1900mm	1200×800×2150mm
料箱容积 Hopper Volume	25L	50L(加大型60L)

简要说明及特点 Brief instruction

该系列半自动充填包装机按照国家GMP标准而设计。设计成：全不锈钢侧开门料仓、可回收吸尘装置、升降工作台等。工作参数配方可储存，备用使用，有10个以上预设配方。适用包装粉粒状物料，如奶粉、饲料、米粉、咖啡、味精、固体饮料、葡萄糖、固体医药等。

This semi-automatic filling and packaging machine was designed in terms of the National GMP Standard. The hopper is sheer, The dust can be collected and the working table height adjustable, Over 10 recipes can be saved for later using. The machine is suitable for packaging powdery product, for instance, milk powder, feed, rice powder, icing sugar coffee, monosodium glutamate, solid beverage, dextrose, solid medicament, etc.

主要特征 Main Features

- 全304不锈钢侧开门料仓，更安全卫生，方便拆卸清洗；
- 伺服马达及伺服驱动控制螺杆；
- PLC控制。触摸屏人机界面显示，操作简便；
- 设计成称重反馈比重跟踪式，克服了因物料比重变化而致使包装重量发生变化的缺点；
- 各种产品调整参数配方可储存，备用使用，最多储存10个配方；
- 更换螺旋附件，能够适应超细粉到小颗粒等多种物料。
- All 304 Stainless steel side open hopper more safe and healthier, easy to open and clean.
- Servo motor drives screw working.
- PLC& Touch Screen make it easy to be operated.
- Weight feedback and proportion track get rid of the shortage of variable packaged weight for various proportion of different material.
- Support save 10 sets parameters of different filling weight for different materials.
- Replacing the auger parts, It is suitable for super thin powder and granule.



DJ-1B3

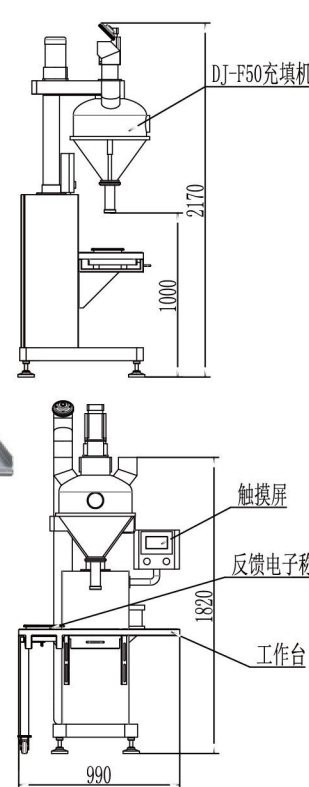

DJ-1B3+50W

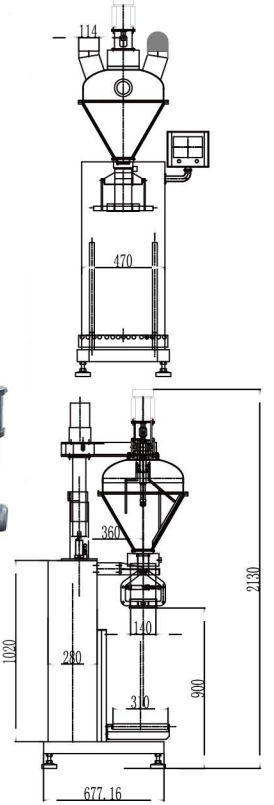

技术参数 Technological parameters

型号 Model	DJ-1B3	DJ-1B3+50W
充填重量 Filling weight	0.1-5Kg	0.1-10Kg
充填精度 Filling accuracy	≤ ±0.2-1%(According to material proportion and pack weight)	
充填速度 Filling speed	10-40times/min	5-10times/min
电源 Power supply	380V/220V 50-60Hz	
整机功率 Total power	2kw	2.5kw
整机重量 Total weight	160kg	180kg
整机体积 Machine size	1200*800*2150mm	700×800×2150mm
料箱容积 Hopper volume	50L	50L
备注 Remark	304stainless steel hopper ,Direct weighing	

简要说明及特点 Brief instruction

该系列包装机能完成计量、充填等工作。由于独特的设计,以至更适用于包装那些易流动或者流动性极差的粉粒状物料,如白砂糖、棉白糖、味精、粉状化妆品、固体饮料、兽药、葡萄糖、固体医药、粉状添加剂、碳粉、爽身粉、农药、染料、香精香料等。

This type can do dosing and filling work. Due to the special professional design, so it is suitable to the fluidic or low-fluidity materials, like condiment, cosmetic, coffee powder, solid drink, veterinary drugs, dextrose, pharmaceuticals, powder additive, talcum powder, agriculture pesticide, dyestuf.

主要特征 Main Features

- 气动夹袋装置和托架装在重量传感器上,根据预先设定的重量进行快速和慢速充填,保证精度。
- 伺服马达及伺服驱动控制螺杆,稳定,精度高;PLC控制、触摸屏人机界面显示,操作简便;
- 快速充填,同时容器下降——重量接近目标值——慢速充填——重量达到目标值——人工取出容器;
- 气动夹袋装置和托罐装置可供选择,轻松满足罐装或袋装;
- 两种工作方式可切换,定量式或称量式
- The Pneumatic clamping and lifting system are installed on the weighing sensor, according to pre-set target weight so that it enables machine to do fast filling and slowly filling. And the high sensitive weighing system ensures high filling accuracy.
- With servo motor and servo drive controlled auger, it performs stably and with high accuracy. PLC control, touch screen display, easy to operate.
- Process: put bag/can (container) on the machine → container raise → fast filling, container declines → weight reaches the pre-set weight → slow filling → weight reaches the target weight → take the container away manually
- Note: the pneumatic bag-clamp equipment and can-hold set are optional, suitable for can or bag filling easily.
- Two working modes: filling by volume (high speed) & filling by weighing (high accuracy)



DJ-1B3+75W

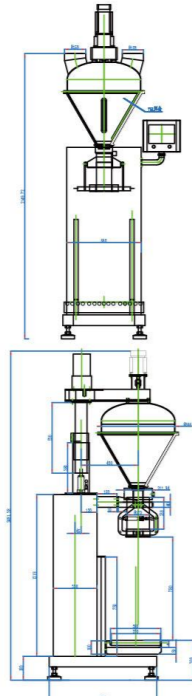

DJ-1C3

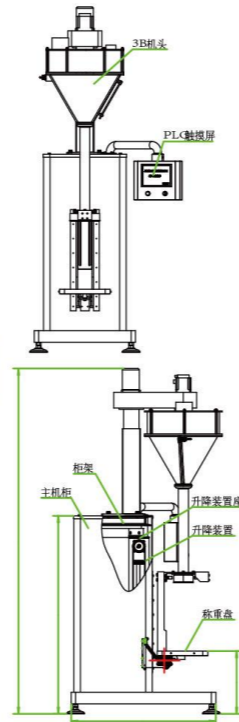

技术参数 Technological parameters

型号 Model	DJ-1B3+75W	DJ-1C3
充填重量 Filling Weight	1-25Kg	10-25Kg
充填精度 Filling accuracy	≤±0.1-0.2%(According to material proportion and pack weight)	
充填速度 Filling speed	1-3times/min	≤2-6 times/min
电源 Power supply	380V/220V 50-60Hz	
整机功率 Total power	3kw	
压缩空气 Air Supply	6kg/cm ² 0.1m ³ /min	
整机重量 Total weight	230kg	300kg
整机体积 Machine size	700×800×2300mm	1150×1000×2800mm
料箱容积 Hopper volume	75L	75L
备注 Remark	304stainless steel hopper ,Direct weighing	

简要说明及特点 Brief instruction

该机是我公司按照国家最新GMP标准而设计开发的一款袋称式包装机,集充填、称重、封口、缝包、输送为一体,适用于颗粒状、粉末状等物料的计量充填包装设备。

The machine is designed under the newest version of GMP standard. Its height is only 1.8m, and combined with filling, weighing, sealing, sewing and conveying together. This machine is suitable for grain and kinds of powder materials.

主要特征 Main Features

- 将物料直接灌入包装袋中计量无需中间斗计量,计量更准确,整机尺寸进一步降低。属于称重方式。
- 专门设计的负压除尘,扬尘可回收,包装过程一尘不染。
- 采用双螺旋加料器,加料方式、加料速度、控制自如。
- 振动夹袋器:密封性好,粉尘不外泄,物料不架桥,入袋物料均匀,防夹手装置。
- 由于该机的物料通道结构及其简单,对于经常需要清洗或更换物料的使用要求非常适合。
- 多种附件可供选择:不同规格的输送带、缝纫机、封口机、夹袋器等供客户选择。
- The machine direct filling in packing bags, measure more nicely, overall size is further reduced, and gross weighing.
- Two layer structure of weighing, concentrate dedusting, workshop is no pollution.
- Double auger feeder, control the feeding mode and speed freely.
- Vibrational bag gripper: avoid product leakage and product blocking, and have more even product feeding.
- Simple-structure of material access, easily for cleaning and shifting materials.
- Multiple kinds of conveyor, bag sealing/seaming machine, bag gripper optional.

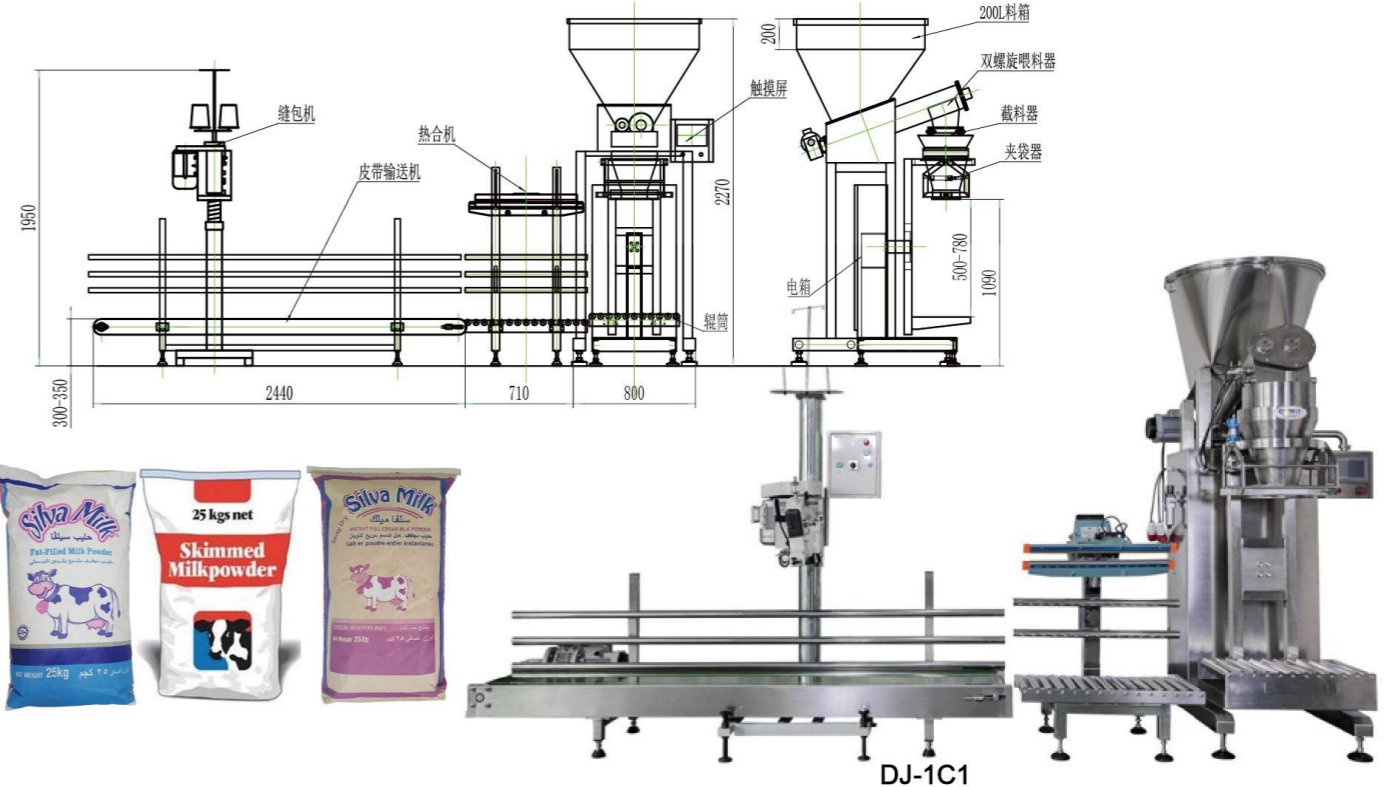

技术参数 Technological parameters

计量方式	称量式(毛重)	Metering Mode	weighing mode (Gross weight)
喂料方式	双螺旋、双阀门、双槽振动(供选择)	Feeding Mode	Double screw, Double valve, double vibrating chute (optional)
充填重量	10-50千克(加大型20-100千克)	Package Weight	10-50kg (20-100kg for oversized ones)
充填精度	±0.2%	Package Accuracy	±0.2%
充填速度	≤3包/分	Packaging Speed	≤3 bags per minute
电源	三相380V/220 50-60Hz	Power Supply	Three-phase 380 V (or single-phase 220 V) 50-60Hz
整机功率	3.9KW(整套功率)	Total Power	3.9kw(power for air supply not included)
气压	6-8Kg/m ²	Atmospheric Pressure	6-8kg/cm ²
用气量	0.2m ³ /min	Use Tolerance	0.2m ³ /min
整机重量	400千克	Total Weight	400kg
整机体积	4000(视输送带而定)×1200×2400mm	Overall Dimensions	4000 (variable depending on the conveyor) 1200×2400mm

简要说明及特点 Brief instruction

该系列自动定量包装秤主要构成部件有：进料机构、称重机构、气动放料机构、夹袋机构、除尘机构、电控部分等组成的一体化自动包装系统。该系统设备通常用于对固体颗粒状物料以及粉末状物料进行快速、定量的敞口袋定量称重包装，如大米、豆类、奶粉、饲料、金属粉末、塑料颗粒及各种化工原料。 Automatic fixed-quantity packaging steelyard of this series including feeding-in, weighing, pneumatic discharging, bag-clamping, dust removal, electrical-controlling integrated automated packaging system. This system normally used for open pocket fast and quantitative weighing packing for solid grain material and powder material, such as rice, legume, milk powder, feedstuff, metal powder, plastic granule and all kinds of chemical raw materials.

主要特征 Main Features

- 由PLC、触摸屏和称重系统构成控制核心，最大限度地提高了机器的称重控制精度和稳定性；
- 整机除电器外其余均为304不锈钢制成，能够适用于腐蚀性化工原料；
- 集中除尘，车间无粉尘污染，残料清洗方便，可用水冲洗；
- 气动夹袋器，密封性好，大小可更换，能够适应多种尺寸包装袋；
- 可选喂料方式，双螺旋、双振动、自由落料；
- 加配皮带输送机、缝包机、折边机或热合机等可以成为成套包装系统。
- PLC, Touch screen & Weighing system control. Maximize the accuracy of weighing and stability.
- Whole machine except for electric part is made of stainless steel 304, suit for causticity chemical raw material.
- Dust Concentration, no powder pollution in the workshop, rest material cleaned convenient, rinse with water.
- Changeable pneumatic bag clap, tight sealing, fit for all size of bag.
- Alternative feeding method, double screw, double vibration, free blanking.
- With belt-conveyor, sewing machine, folding machine or heat sealing machine can be a complete packing system.

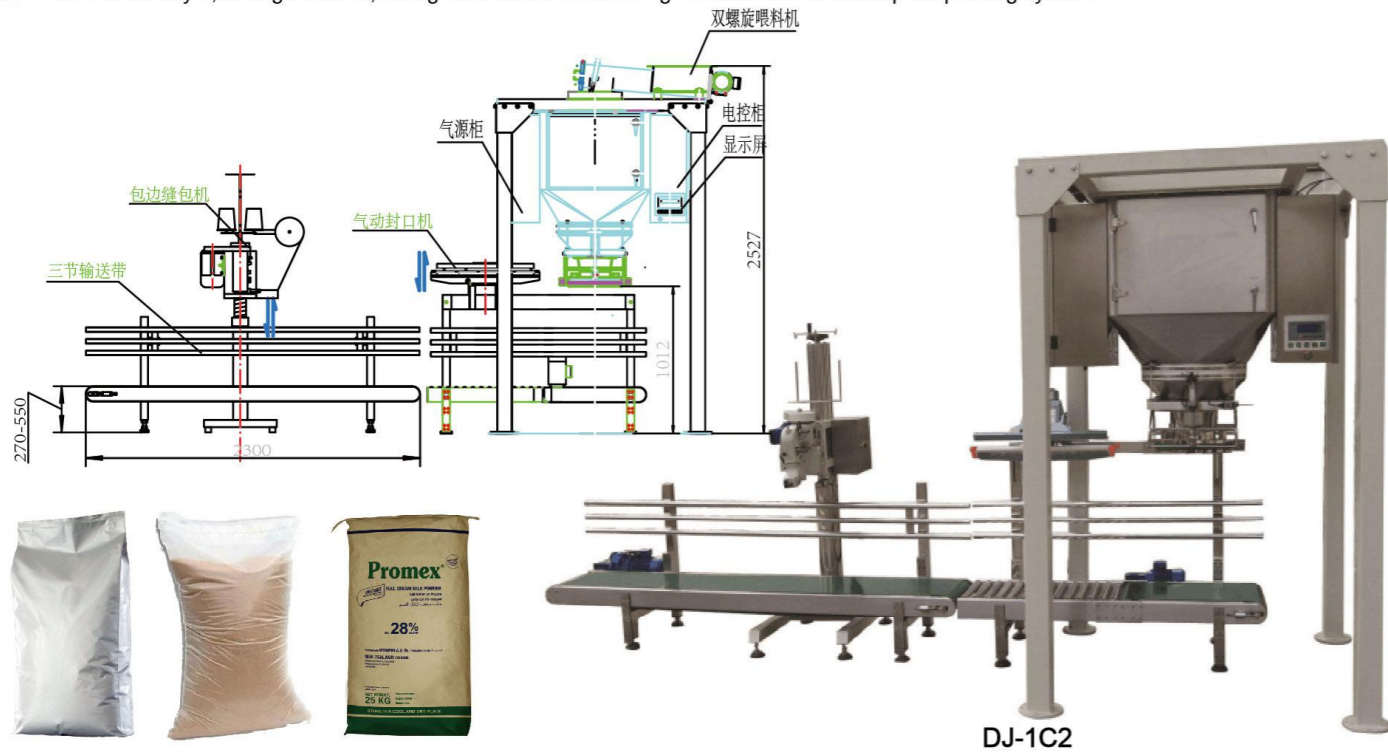

技术参数 Technological parameters

型号	DJ-1C2	Model	DJ-1C2
计量方式	净重式称重	Dosing Mode	Net weight weighing
充填重量	10-50Kg	Filling weight	10-50Kg
充填精度	≤±0.2%(According to material proportion and pack weight)	Filling accuracy	≤±0.2%(According to material proportion and pack weight)
充填速度	≤3-4包/分	Filling speed	≤3-4bags/min
电源	380V/220V 50-60Hz	Power supply	380V/220V 50-60Hz
整机功率	3.9kw	Total power	3.9kw
压缩空气	6kg/cm² 0.3m³/min	Air Supply	6kg/cm² 0.3m³/min
整机重量	500kg	Total weight	500kg
整机体积	4500(according to belt conveyor)×1200×2500mm	Machine size	4500(according to belt conveyor)×1200×2500mm
备注	整机304不锈钢材质	Remark	304 stainless steel

简要说明及特点 Brief instruction

本机适用于医药、日化、食品、农药及特殊行业等产品，如食品添加剂、干燥剂、奶粉及各种粉类。 This machine is suitable for pharmaceutical, cosmetic, food, pesticides and special industries, and other products, such as food additives, desiccant, milk powder and all kinds of powder.

主要特征 Main Features

- 可在包装过程中自动完成充填、计量、制袋封口、切断、热压、批号等全部工作，光电跟踪定位无需调整。
- 智能控制系统、触摸屏操作界面。只需设定参数即可精确制系统运作。
- 热封器对袋边均匀加热控制，上下两侧可单独调温。
- 更换刀具可实现一字形、花纹形切断、一字形连带切断，切袋平稳可靠不卡袋，操作简单，可配置轮式打码机，进行排打批号保质期等。
- Can be done automatically from packaging filling, metering, bag-making, sealing, cutting, pressing, lot number. All work with standard photoelectric positioning without adjustment.
- Intelligent control systems, English LCD display. Simply set the parameters, then can be precisely controlled system operation.
- Sealing the bag side pairs uniform heating control, both sides of the upper and lower thermostat separately.
- Replace the tool can achieve a shape, pattern-shaped cut, cut a shape joint, smooth and reliable cutting bags are not card pockets, easy to operate, can be configured wheeled coders, were ranked batch number shelf life, etc.

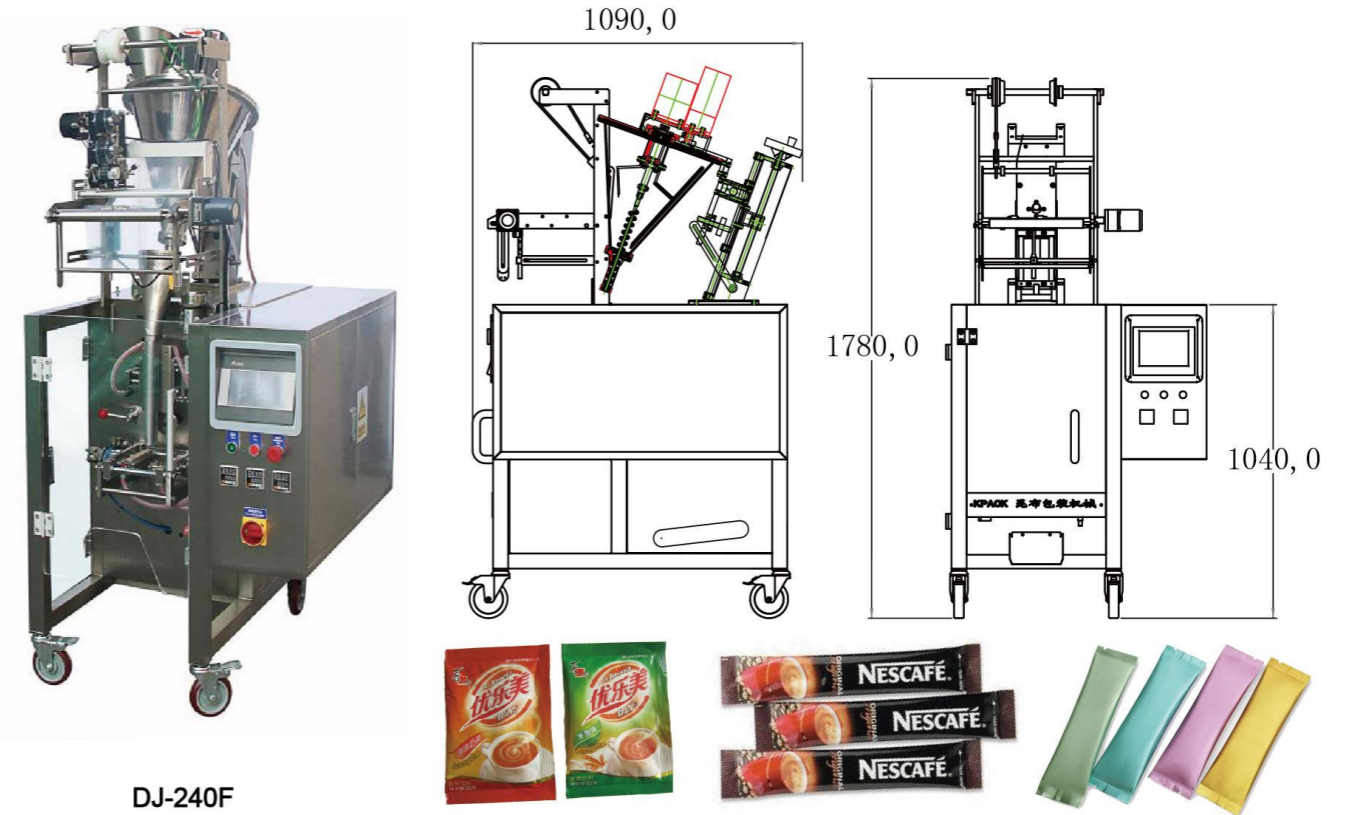

DJ-240F

技术参数 Technological parameters

产品名称	全自动粉末袋装机	product name	Automatic powder bag packaging machine
型号	DJ-240F	model	DJ-240F
计量方式	螺杆	Measurement methods	Screw
封装方式	三边封、四边封、背封	Packing type	three-side seal, four-side seal, back seal
计量范围	10-100g (视物料而定)	Filling weight	10-100g (according to material specific)
制袋尺寸	长20-150mm; 袋宽15-110mm	Bag size	Length20-150mm; pouch width15-110mm
包装速度	30-40包/分钟	Packing speed	25-50 packs / min
控制系统	PLC控制系统	Control System	PLC control system
电源	AC220V/50Hz	power supply	AC220V/50Hz
功率	1.5KW	power	1.5KW
重量	150KG	weight	150KG
外形尺寸	L600×W760×H1530mm	Dimensions	L600×W760×H1530 mm

简要说明及特点 Brief instruction

本机与计量机配套可自动完成计量、送料、充填、制袋、日期打印、充气(排气)、成品输送的全部包装过程,并自动完成计数。适用于包装奶粉、蛋白粉、固体饮料、白砂糖、葡萄糖、咖啡粉、香料、食品添加剂等。

This Machine can complete the whole packing procedure of measuring, loading materials, filling, bagging, date printing, charging(exhausting) and products transporting automatically as well as counting. The machine can be used in powder and granular material, like milk powder, protein powder, solid drink, white sugar, dextrose, coffee powder, seasoning, food additives and so on.

主要特征 Main Features

- 设备采用伺服驱动拉膜、放膜,确保拉膜精准,包装袋型效果整齐美观;
- 设备配件采用国内/国际名牌电气元件,并经过多年市场实践检验,确保性能更稳定、耐用;
- 整机设计符合GMP标准,并通过CE认证;
- 整机采用304不锈钢材质,符合药食生产规范,便于清洁卫生;
- 计量螺杆采用数控机床精密加工制造,工艺稳定,计量精度高;
- 采用伺服电机驱动控制,性能快速平稳,生产速度快。
- Servo driven film-pulling and film-loading to make the film position more accurate and finished bags more beautiful and neater;
- Domestic and overseas famous brand components, and with years of market practice, ensure machine performance more stable and durable;
- Machine design conforms to GMP standard, with CE certification;
- Machine frame in stainless steel #304, suitable for pharmacy and food products production, simple operation and easy cleaning;
- CNC machine processing, high accurate screws design, ensure best precision filling;
- Servo motor-controlled system, performance more stable and filling speed faster.



DJ-3A180



有机玻璃计量螺杆
Plexiglass Auger Filler



螺旋上料机
Inclined screw conveyor



真空上料机
Vacuum Feeder



304不锈钢计量螺杆
304 Stainless Steel Auger Filler



横向螺旋给料机
Horizontal Screw Feeder



成品输送机
Finished Product Conveyor

技术参数 Technological parameters

型号 Model	DJ-3A180
计量方式 Filling weight	螺杆定量/称重反馈跟踪(Auger filling or weighing feedback)可选配
包装袋型 Bag shape	背封、插脚、连包、打孔 Pillow bag、pin bag、chain bag、hole bag
充填重量 Filling weight	10-100g(Accord to powder specific)
充填精度 Filling accuracy	≤ ±0.5-1%(According to material proportion and pack weight)
充填速度 Filling speed	50-90bags/min
电源 Power Supply	380V/220V 50-60Hz
整机功率 Total power	3kw
压缩空气 Air supply	6-8kg/cmm ²
整机重量 Total weight	450kg
整机体积 Machine size	1300X900X1600mm

简要说明及特点 Brief instruction

本机与计量机配套可自动完成计量、送料、充填、制袋、日期打印、充气(排气)、成品输送的全部包装过程,并自动完成计数。适用于包装奶粉、蛋白粉、固体饮料、白砂糖、葡萄糖、咖啡粉等。

This machine can complete the whole packing procedures of measuring, loading materials, filling, bagging, date printing, charging (exhausting) and products transporting automatically as well as counting. It can be used in powder and granular material, like milk powder, protein powder, solid drink, white sugar, dextrose, coffee powder, and so on.

主要特征 Main Features

- 该包装机采用皮带牵引拉膜;牵引结构采用伺服电机,定位精度高,易于调整;
- 采用PLC伺服系统、气动控制系统、超大显示触摸屏构成驱动控制核心;最大限度提高了整机的控制精度、可靠性和智能化程度;
- 触摸屏能储存多种不同产品的包装工艺参数,当更换产品时可随时使用无需重新设定;
- 可以不停机直接在触摸屏上调整封切位置,纠偏等;
- 带有自动报警功能,如门未关、无卷膜、无色带等;
- 该机适合做枕式包、立袋、连包袋、手拎袋。
- The packaging machine adopts belt traction film: The traction structure adopts servo motor, and the positioning accuracy is easy to adjust;
- The horizontal seal adopts high-power servo motor, the transverse seal pressure and the open stroke can be adjusted at any time, suitable for various packaging materials;
- Touch screen can store the technical parameters of various kinds of products, no need to reset while products changing.
- It can adjust the sealing and cutting position, correcting deviation, etc directly on the touch screen without stopping the machine;
- With automatic alarm function, such as door not closed, no film, no ribbon, etc.;
- This machine is suitable for Pillow bag, Triangle bag, Chain bag, Hole bag.



DJ-3B(250)

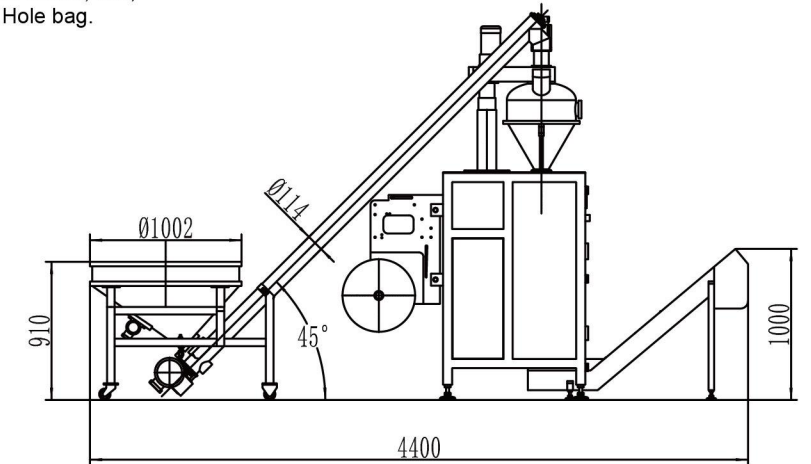

技术参数 Technological parameters

型号 Model	DJ-3B250	
计量方式 Filling Weight	螺杆定量/称重反馈跟踪 (Auger filling or weighing feedback) 可选配	
包装袋型 Bag shape	背封、插脚、连包、打孔 Pillow bag、pin bag、chain bag、hole bag	
充填重量 Filling weight	50-500g(Accord to powder specific)	100-1000g(Accord to powder specific)
制袋尺寸 Bag sizes	L:80-300mm ,W:60-200mm	L:100-320mm ,W:100-250mm
充填精度 Filling accuracy	≤ ±0.5-1%(According to material proportion and pack weight)	
充填速度 Filling speed	≤ 20-40 bags/min	
电源 Power supply	380V/220V 50-60Hz	
整机功率 Total power	3kw	4.4kw
压缩空气 Air Supply	6kg/cm ² 0.2m ³ /min	6kg/cm ² 0.25m ³ /min
整机重量 Total weight	500kg	900kg
整机体积 Machine size	1350×1200×2500mm	1430×1200×2600mm

简要说明及特点 Brief instruction

这套设备主要由给袋式全自动包装机与螺杆秤、螺杆送料器、专用吸尘器配套而成，适用于农药、兽药、奶粉、葡萄糖、咖啡粉、调味品、添加剂等粉末物料的自动完成送料、可自动取袋、打码、开袋、定量计量、吸尘、填充、热封、输出成品的包装机。

This machine is mainly composed of automatic bag packing machine, screw scale, screw feeder and dust removal device.

It is for pesticides, veterinary drugs, milk powder, dextrose, coffee powder, spices, additives and other powder materials, Automatic feeding, automatically take bag, coding, open bags, quantitative measurement, dust removal, sealing, output of finished packaging machine.

主要特征 Main Features

- 包装袋适应范围广：对于单层PE、PE复合材质、CPP复合材质、铝箔等材质多层复合制成的预制袋。
- 包材损耗低：本机使用的是预制袋，包装袋图案完美，封口质量好，从而提高了产品档次。
- 快速更换包装袋规格：机械手装置的轻松快捷调节。
- Bags wide adaptation: For single layer PE, PE composite material, CPP composite material, aluminum foil and other materials made of prefabricated multilayer composite film bags.
- Low packing material loss: This machine uses preformed bag, the bag pattern is perfect, good sealing quality, resulting in improved product quality.
- Quick-change bag size: robotic device quick and easy adjustment.

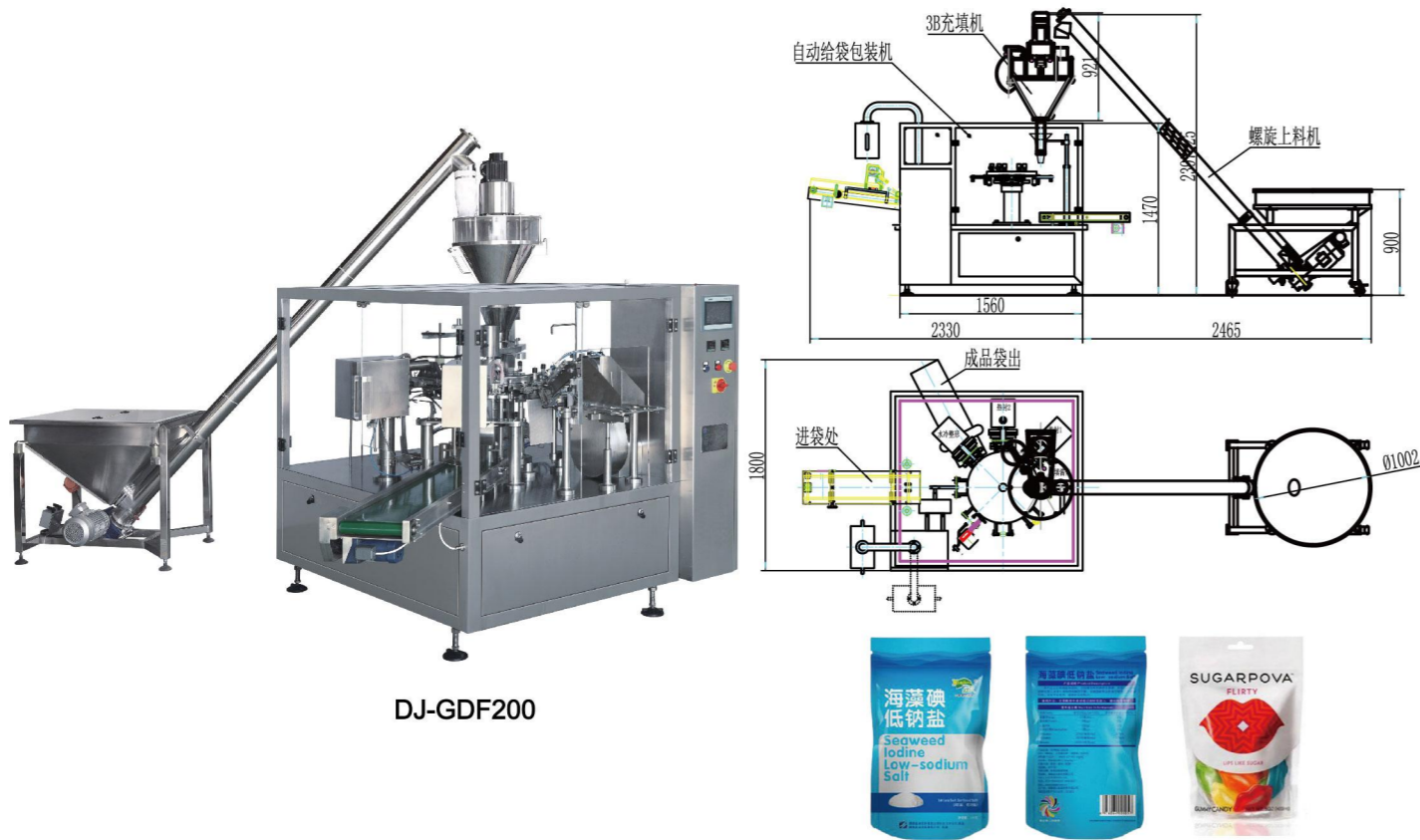

DJ-GDF200

技术参数 Technological parameters

型号	DJ-GDF200	Model	DJ-GDF200 automatic powder rotary pack machine
封口方式	自立袋、平面袋(三边封、四边封、手提袋)、纸袋等复合袋	Sealing Type	Stand-up pouch, flat bag (three-side seal, four-side seal, tote bag), paper bag, etc.
包装尺寸	W: 100 ~ 200mm L: 100 ~ 300mm	Making type	W: 100 -200mm L: 100 - 300mm
充填范围	10-500g 10-2000g (需更换螺杆附件)	Filling range	10-2000g (By screw attachment)
包装速度	10-50bag/min (具体速度由物料自身及填充重量决定)	Packaging speed	10-50bag/min (according to material itself and the filling weight)
包装精度	重量 100 克偏差 ±2% 100-500g 偏差 ±1% 2000g 偏差 ±0.5%	Packaging precision	≤±0.5-2%(according to material itself and the filling weight)
电源	三相 380V、50/60Hz	Power Supply	Three-phase 380V, 50/60Hz
整机功率	4.5kw	Total Power	4.5KW
外型尺寸	4600×2000×2430mm	Overall Dimensions	4600×2000×2430mm
备注	根据客户要求, 提供特殊设计	Note	Special design according to customer requirements
可选配	上料机, 成品输送机	optional	auger feeder ,Belt conveyor
调节袋子	自动调节	Adjust bag size	automatic adjust

简要说明及特点 Brief instruction

该机是一款经济实用的粉末及小颗粒自动灌装机，能完成瓶子自动定位、充填及计量等工作，它由一台螺杆计量机、一台链板输送带及一个气动定位系统组成，可与理瓶机、旋盖机、贴标机等组成整套灌装流水线。适用于包装粉末、小颗粒药品、奶粉、兽药、调味品、粉粒状添加剂、葡萄糖、固体饮料、爽身粉、农药等。

This Machine is an economical practical powder automatic filling machine, which can complete automatic bottle positioning, filling and metering. It consists of a filling head, an independent motorized chain conveyor and a pneumatic positioning system. Suitable for fluidic low-fluidity materials, such as milk powder, veterinary drugs, condiments, powdered additives, glucose, solid beverages talcum powder, pesticides, etc.

主要特征 Main Features

- 全不锈钢结构，组合式透明侧开门料仓，更安全卫生，方便拆卸清洗；
- 伺服马达及伺服驱动控制螺杆；PLC控制，触摸屏人机界面显示，操作简便；
- 设计成称重反馈比重跟踪式，克服了因物料比重变化而使包装重量发生变化的缺点；
- 各种产品调整参数配方可储存，后备使用，最多储存10个配方；
- 更换螺旋附件，能够适应超细粉到小颗粒等多种物料。
- All 304 Stainless steel side open hopper, more safe and healthier, easy to open and clean.
- Servo motor drives screw working. PLC& Touch Screen make it easy to be operated.
- Weight feedback and proportion track get rid of the shortage of variable packaged weight for various proportion of different material.
- Support save 10 sets parameters of different filling weight for different materials.
- Replacing the auger parts, It is suitable for super thin powder and granule.

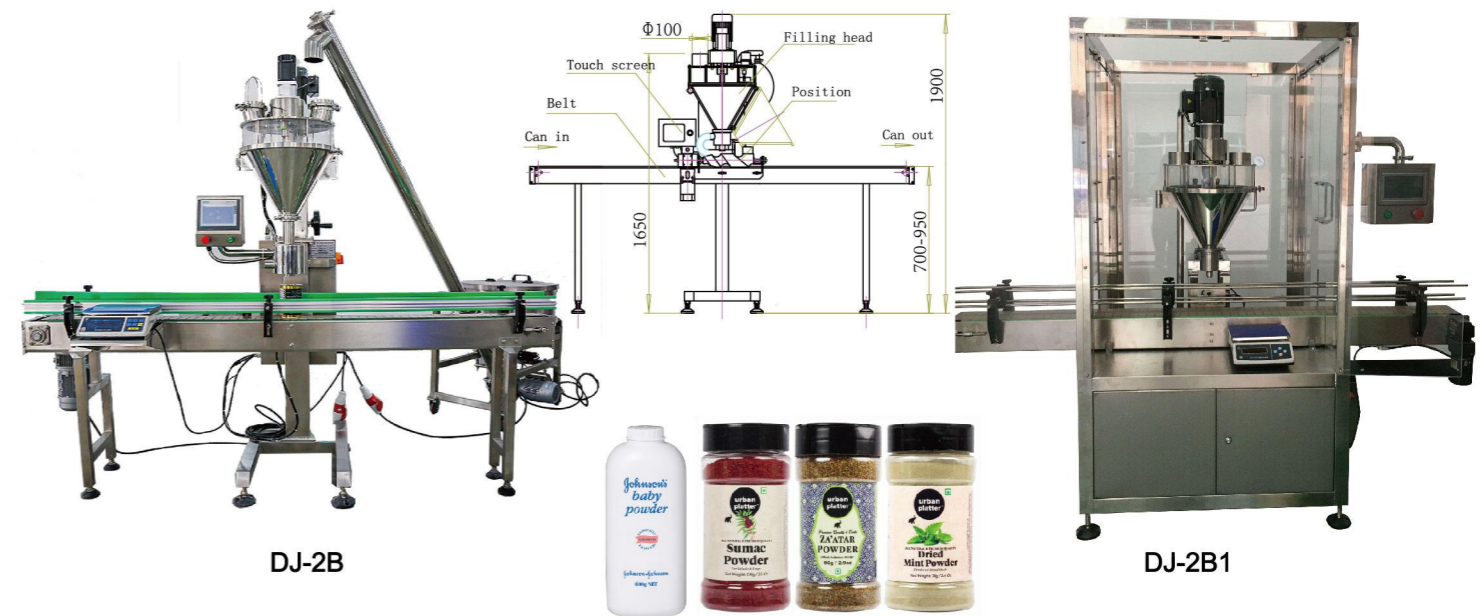

DJ-2B

DJ-2B1

技术参数 Technological parameters

型号	Mode	DJ-2A	DJ-2B	DJ-2B1
充填重量	Filling Weight	10-500g	50-5000g	50-5000g
充填精度	Filling Accuracy	≤ ±0.5-2%(According to material proportion and pack weight)		
充填速度	Filling Speed	10-20times/min		
电源	Power Supply	380V/220V 50-60Hz		
整机功率	Total Power	1.5kw	2kw	2kw
整机重量	Total Weight	180kg	300kg	400kg
整机体积	Machine size	2400×800×1850mm	2400×900×2050mm	2400×900×2150mm
料箱容积	Hopper volume	25L	50L	50L
压缩空气	Air Supply	6kg/cm ² 0.2m ³ /min		
设备材质	Machine material	304 stainless steel		

简要说明及特点 Brief instruction

单头听装机第三代产品，该罐（听）装自动充填包装机完成喂罐、计量、充填、称重、反馈、排废等工作，适用包装粉状物料。如奶粉、米粉、白糖、咖啡、味精、固体饮料、葡萄糖、固体医药等。

This automatic canned filling and packaging machine was designed for automatic can feeding, weighing, filling, Feedback and failed packs inspect&reject. The machine is suitable for packaging powdery & grainy product, for instance, milk powder, monosodium glutamate, solid beverage, icing sugar, dextrose, feed, coffee, solid medicament, powdery & grainy additive, dye, etc.

主要特征 Main Features

- 中/英文触摸屏人机界面，PLC控制系统，伺服电机驱动充填螺旋。
- 使用罐或瓶状容器包装，配置自动喂罐系统，可实现无瓶、缺瓶不罐装。
- 开门料箱，人性化易洗框式机架，整机结构、布局合理，更换包装品种，清理卫生及为方便。
- 称重反馈比重跟踪，重量超差报警、故障报警提示和排废功能，确保产品合格率。
- 工作数量可储存，后备使用。
- 有托罐、振动、吸尘功能。
- Chinese/English touch screen and HMI, PLC control system, Auger is driven by servo motor.
- Equipped with automatic can/bottle feeding system, realize functions of no-can-no-filling.
- Open-door hopper, a frame type machine be designed the humanization to easily wash. Reasonable mechanical structure, easy to change size parts and clean up.
- The functions of over-weight warning, error message display and failed packs inspecting & rejecting, which never let any reject to pass through, ensure the packing quality.
- Have the functions of can support, vibration and dust extraction.



DJ-2B2

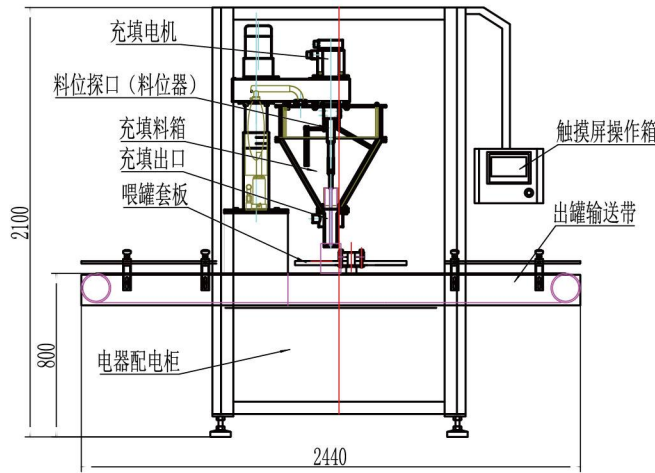

技术参数 Technological parameters

充填重量	10-5000克	Filling Weight	10-5000g
计量方式	螺旋定量之后称重反馈跟踪	Dosing way	Auger filling with instant weight feedback
称重范围	1-6000(分辨率1克)	Weighing Range	1-6000g(with a resolution of 1g)
充填精度	≤ ±0.3-1% (不同的物料特性或充填重量参数有可能变化)	Packaging Accuracy	≤ ±0.3-1% (According to packing weight and product specs)
充填速度	15-30罐/分	Packaging Speed	15-30 cans per minute
电源/功率	380/220V 50-60HZ/2kw	Power Supply/Total Power	380/220V 50-60Hz/2kw
用气量/气压	0.2m³/min / 6-8kg/cm²	Use Tolerance/Air Pressure	0.2m³/min / 6-8kg/cm²
整机重量	450千克	Total Weight	450kg
整机体积	2500×1245×2300mm	Overall Dimensions	2500×1245×2300mm
容器体积	圆柱型容器φ 50-180mm 高50-350mm	Container Size	cylindrical conntainers with a diameter of 50-180mm and a height of 50-350mm

简要说明及特点 Brief instruction

按照国家GMP标准设计开发的一款双填充高精度罐装机，适用包装粉状物料，如：奶粉、米粉、味精、固体饮料、葡萄糖、食品添加剂、碳粉、灭火器填料等化工原料。

This dual filling machine with high accuracy is designed in terms of the National GMP Standard. Thekaging powdery & grainy product, for instance, milk powder, rice powder, monosodium glutamate, solid beverage, dextrose, etc.

主要特征 Main Features

- 设计成称重后二次补充使精度和速度得到全面提升。
- 自动空罐去皮循环，自动二次检重。少量循环补充等智能高级功能。
- 彩色触摸屏人机界面，PLC控制系统。
- 三套伺服电机驱动系统运转，定位准确，精度高、转速可设定。
- 整机结构、布局合理，更换包装品种、清理卫生及为方便。
- 更换螺旋附件，能够适应超细粉到颗粒状等多种物料。
- 全密封充填，有托罐、振动、吸尘功能。
- Designed for dual weighing & dosing, Imporve speed and accuracy
- Automatic and cirulative empty cans peeling off. Automatic twice check, circulative reiorforce.
- Working states & operation messages shows in Chinese/English by color touch screen HMI PLC has better stability.
- Filling system is driven by three sets of servo motor, accurate positioning, high precision and setttable rotary speed.
- Reasonable mechanical structure, easy to change size parts and clean up
- Through changing accessories, the machine is suitable for multiple products, no matter super fine powdery or large grains.
- Have the functions of can support, vibration and dust extraction.



DJ-2B3

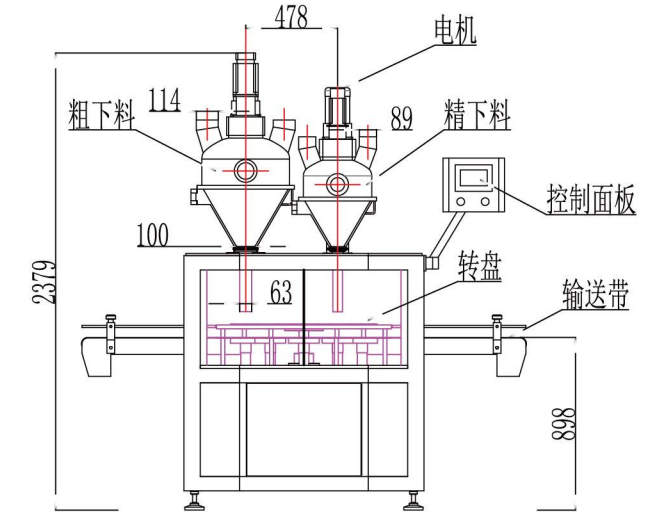

技术参数 Technological parameters

充填重量	10-5000克	Filling Weight	10-5000g
计量方式	螺旋定量、称重后循环补充	Dosing way	Auger filling with instant weight feedback
料箱容积	预充50L, 补充25L	Hopper Volume	50L, 25L
充填精度	≤ ±1.5克	Packaging Accuracy	≤ ±1.5g
整机速度	20-55罐/分	Packaging Speed	20-55 cans per minute
电源/功率	380V 50-60HZ/3.5kw	Power Supply/Total Power	380V 50-60HZ/3.5kw
气压/用气量	6-8 千克/cm² 0.2m³/min	Use Tolerance/Air Pressure	6-8 kg/cm² 0.2m³/min
整机重量	700千克	Total Weight	700kg
整机体积	3330×1200×2300mm	Overall Dimensions	3330×1200×2300mm
适用容器体积	圆柱型容器φ 50-180mm 高50-350mm	Container Size	cylindrical conntainers with a diameter of 50-180mm and a height of 50-350mm

简要说明及特点 Brief instruction

该机是一款经济实用的粉末及小颗粒自动灌装机，能完成瓶子自动定位、充填及计量等工作，它由一台双充填螺杆计量机、一台双排链板输送带及两个气动定位装置组成，可与理瓶机、旋盖机、贴标机等组成整套灌装流水线。适用于包装粉末、小颗粒药品、奶粉、兽药、调味品、粉粒状添加剂、葡萄糖、固体饮料、爽身粉、农药等。

This Machine is a complete, economical solution to your filling production line requirements. It consists of the Two Filling Head, an independent motorized chain conveyor mounted on a sturdy, stable frame base, and all necessary accessories to reliably move and position containers for filling, dispense the required amount of product, then quickly move the filled containers away to other equipment in your line (e.g., cappers, labelers, etc.). It fits more to the fluidic or low-fluidity materials, like milk powder, albumen powder, pharmaceuticals, condiment, solid drink, white sugar, dextrose, coffee, agriculture pesticide, granular additive, and so on.

主要特征 Main Features

- 全不锈钢结构；组合式透明料箱，无需工具即可方便拆洗。
- 伺服马达及伺服驱动控制螺杆。PLC、触摸屏及称重模块控制。
- 各种产品调整参数配方可储存，备后使用，最多储存10个配方。
- 更换螺旋附件，能够适应超细粉到小颗粒等多种物料。
- 配有位置合理的高度调节手轮，方便调整机头高度。
- Stainless steel structure; The quick disconnecting hopper could be washed easily without tools.
- Servo motor drive screw. PLC, Touch screen and weighing module control.
- To save all product's parameter formula for later use, save 10 sets at most.
- Replacing the auger parts, it is suitable for material from super thin powder to granule.
- Include handwheel of adjustable height.



DJ-2B-2

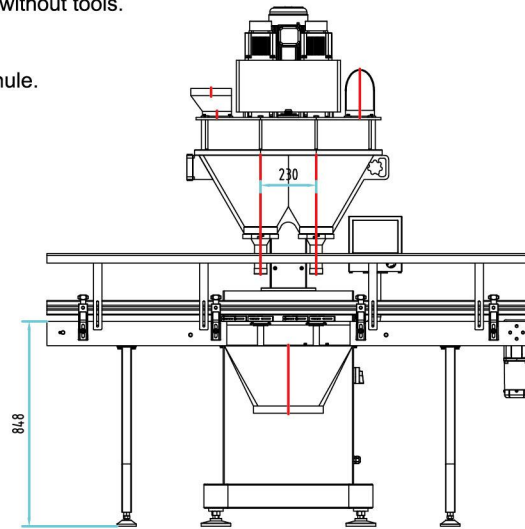

技术参数 Technological parameters

型号 Mode	DJ-2B-2		
工位 Working position	双排带+双充填 2 lines + 2 filler	单排带+双充填 1 lane + 2 fillers	单排带+双充填 1 lane + 2 fillers
计量方式 Dosing way	螺杆定量 Directly dosing by auger		
罐装重量 Filling weight	1 - 2000g	10 - 5000g	1 - 500g
罐装精度 Filling Accuracy	≤ 100g, ≤ ±1.5%; 100 - 500g, ≤ ±1%; 500 - 2000g, ≤ ±0.5%; 1 - 10g, ±3-5%; 10 - 100g, ≤ ±2%; 100 - 500g, ≤ ±1%		
罐装速度 Filling Speed	50 - 70 瓶/分钟 50 - 70 bottles per min		
电源 Power Supply	3P AC208-415V 50/60Hz		
压缩空气 Air Supply	6 kg/cm ² 0.05m ³ /min	6 kg/cm ² 0.1m ³ /min	
整机功率 Total power	2.6kW	2.87kW	2.02kW
整机重量 Total Weight	400kg	400kg	240kg
整机体积 Overall Dimensions	2000×1050×2030mm	3000×980×2150mm	2000×760×1850mm
料箱容积 Hopper Volume	83L	83L	51L

简要说明及特点 Brief instruction

该机符合GMP标准，能完成自动计量、充填、超差报警等工作，适用包装颗粒状、粉粒状、挤压易破碎、膨化颗粒状、吸湿性强和比重不规则变化的物料。适用范围：白糖、盐、洗衣粉、种子、大米、味精、饲料、咖啡、芝麻等日用品、调味品小颗粒状、粉状物料的定量称量。

This semi-automatic filling and packaging machine adapt to the requirement of GMP, can do weighing and dosing automatically, and is suitable for floating grainy products, for instance, rice, peanut, tea, corn, monosodium glutamate, solid beverage, icing sugar, coffee, medicine, washing powder etc., or extended grainy product. extended grainy product.

主要特征 Main Features

- 对包装容器不限制。
- 采用直接称重式，精度高，稳定性强。
- 设计成振动给料，结构简单，维护方便，故障率低。
- 中/英文触摸屏人机界面，PLC控制系统。
- 对于多粉尘物料出口配置吸尘装置。
- Product container unlimited.
- Directly weighing, therefore extremely high precision.
- Designed for vibrational feed-in, which has simple structure, convenience for maintenance and low failure rate.
- Chinese/English is displayed in touch screen. HMI using PLC and touch, screen.
- Dust extraction device is optional to mounted in the mouth of the filling tube for floating products.



DJ-Z1

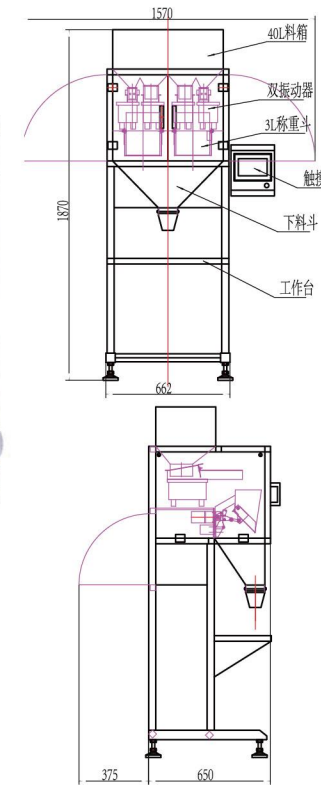

DJ-Z2

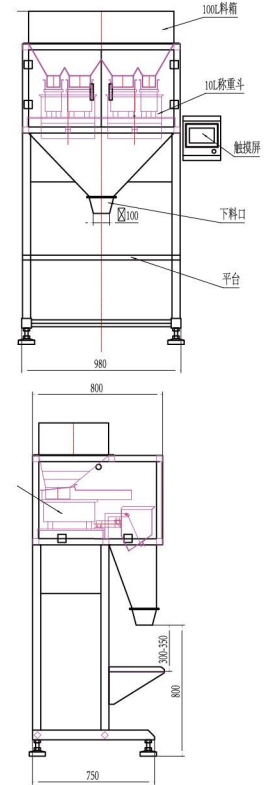

技术参数 Technological parameters

型号 Model	DJ-Z1	DJ-Z2
计量方式 Metering Mode	振动给料称重 (净重) Vibrating & weighing (net weight)	
称重范围 Weight Range	50-1000g	200-5000g
充填精度 Packing Accuracy	重量 ≤ 200g, 误差 ≤ ±1g; 重量 > 200g, 误差 ≤ ±2g	重量 ≤ 1000g, 误差 ≤ ±2g; 重量 > 1000g, 误差 ≤ ±5g
充填速度 Packing Speed	8-15bags/min	8-15bags/min
电源 Power Supply	单相220V 50-60Hz / Single-phase 220V 50-60Hz	
整机功率 Total Power	1.1KW	1.5KW
整机重量 Machine Weight	150KG	180KG
整机体积 Machine Size	650×680×1790mm	970×860×2100mm

简要说明及特点 Brief instruction

该机符合GMP标准，能完成自动计量、充填、超差报警等工作，适用包装颗粒状、粉粒状、挤压易破碎、膨化颗粒状、吸湿性强和比重无规则变化的物料。适用范围：白糖、盐、洗衣粉、种子、大米、味精、饲料、咖啡、芝麻等日用食品、调味品小颗粒状、粉状物料的定量称量。

This semi-automatic filling and packaging machine adapt to the requirement of GMP, can do weighing and dosing automatically, and is suitable for floating grainy products, for instance, rice, peanut, tea, corn, monosodium glutamate, solid beverage, icing sugar, coffee, medicine, washing powder etc., or extended grainy product, extended grainy product.

主要特征 Main Features

- 对包装容器不限制。
- 采用直接称重式，精度高，稳定性强。
- 设计成振动给料，结构简单，维护方便，故障率低。
- 中/英文触摸屏人机界面，PLC控制系统。
- 对于多粉尘物料出口配置吸尘装置。
- Product container unlimited.
- Directly weighing, therefore extremely high precision.
- Designed for vibrational feed-in, which has simple structure, convenience for maintenance and low failure rate.
- Chinese/English is displayed in touch screen. HMI using PLC and touch screen.
- Dust extraction device is optional to mounted in the mouth of the filling tube for floating products.



DJ-Z3

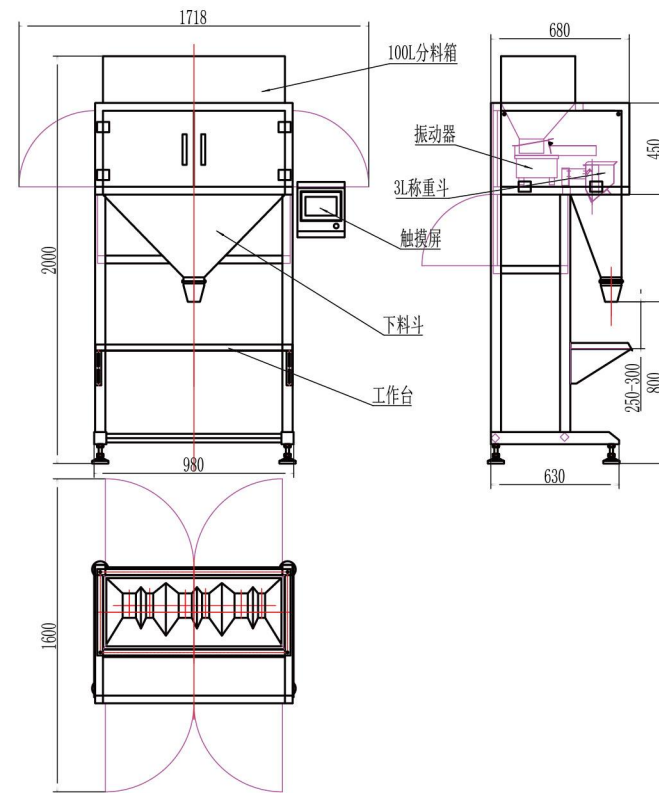

技术参数 Technological parameters

计量方式	称量式(三个4.5L量斗计量)	Metering Mode	Gross weighing mode(Three 4.5L hopper to weighing)
给料方式	双振动下料、补料	Feeding Mode	Double vibrating
包装重量	50-1000g	Package weight	50-1000g
包装精度	±0.2%	Packing Accuracy	±0.2%
包装速度	12-30袋/分钟	Packing Speed	12-30bags/min
工作电压	220V 50-60HZ	Power Supply	220V 50-60HZ
整机功率	2.3KW	Total Power	2.3KW
整机重量	150kg	Total weight	150kg
整机体积	970×750×2100mm	Overall dimensions	970×750×2100mm
料箱容积	120L	Hopper volume	120L

简要说明及特点 Brief instruction

该包装机能完成：计量、夹袋、充填等工作。专为颗粒物料包装而设计，适用于各种颗粒物料的包装。

This packaging machine includes weighing, sealing, filling and some other functions. Design for the grain material's packaging. Suitable for many kinds of grain material's packaging.

主要特征 Main Features

- 本机采用闸门给料、振动补料，以保证有较高的包装精度。
- 对扬尘较大包装环境，我们为你配置工业吸尘器。
- 整机不锈钢制造，外观设计实用美观。
- 关键器件均采用国内外知名品牌产品，固具有速度快，精度高等特点。
- 本机还可以根据你的要求为你量身定制。
- The machine use valve and vibrating chute for filling. Keep a high packaging accuracy.
- If the working place is dusty. We can deploy Industrial vacuum cleaners for you.
- The whole machine is made of stainless steel. The design is practical and beautiful.
- The key equipments is all use famous brands. So it with high accuracy and high speed.
- The machine even can be customized for you.

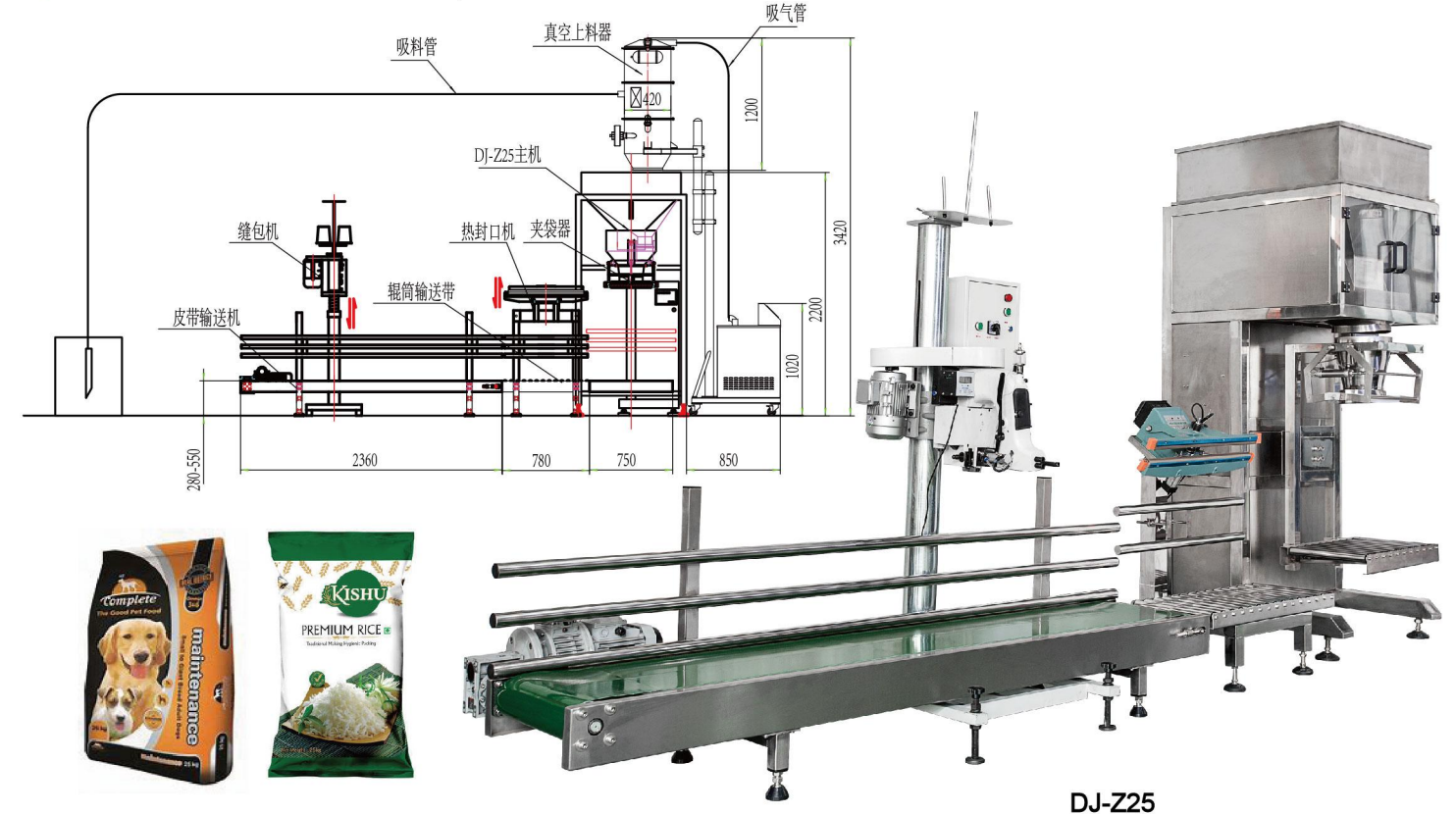

DJ-Z25

技术参数 Technological parameters

型号	DJ-Z25	Model	DJ-Z25
计量方式	毛重称量式	Metering Mode	Gross weighing mode
喂料方式	闸门给料、振动补料	Feeding Mode	Screw and valve feed
包装重量	5-25kg, 10-50kg	Package Weight	2-25kg, 10-50kg
包装精度	±0.2%	Package Accuracy	±0.2%
包装速度	3-6袋/分	Packaging Speed	3-6bags/min
电源	380 220V/50Hz	Power Supply	380 220V/50HZ
压缩空气用量	6千克/平方米 0.2立方米/分钟	Atmospheric pressure and Use Tolerance	6kg/cm ² 0.2m ³ /min
整机功率	2 kw	Total Power	2kw
整机体积	1000mm×1000mm×2400mm	Overall dimensions	1000mm×1000mm×2400mm

简要说明及特点 Brief instruction

适用于食品，医药，化工产品中的松散，无粘性，细小颗粒状，物料的自动包装，如：汤料，冲剂，干燥剂，味精，白糖，麦片等。

Major Application: suitable for automatic packaging of loose, non adhesive and small granules of foods, medicine and chemicals, such as soup material, instant herbal mixture, drying agent, glutamate, sugar and oatmeal etc.

主要特征 Main Features

- 可在包装过程中自动完成充填、计量、制袋、封口、切断、热压、批号等全部工作，光电跟标定位无需调整。
- 智能控制系统、触摸屏操作界面。只需设定参数即可精确控制系统运作。
- 热封器对袋边均匀加热控制，上下两侧可单独调温。
- 更换刀具可实现一字形、花纹形切断、一字形连带切断，切袋平稳可靠不卡袋，操作简单，可配置轮式打码机，进行排打批号、保质期等
- Can be done automatically from packaging filling, metering, bag-making, sealing, cutting, pressing, lot number, All work with standard photoelectric positioning without adjustment.
- Intelligent control systems, English LCD display. Simply set the parameters can be precisely controlled system operation.
- Sealing the bag side pairs uniform heating control, on both sides of the upper and lower thermostat separately.
- Replace the tool can achieve a shape, pattern-shaped cut, cut a shape joint, smooth and reliable cutting bags are not card pockets, easy to operate, can be configured wheeled coders, were ranked batch number, shelf life, etc



DJ-240K

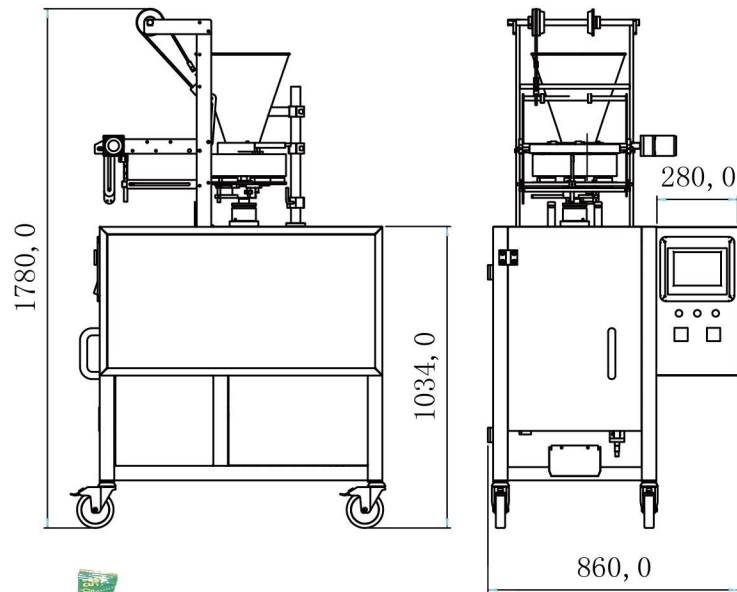

技术参数 Technological parameters

型号	DJ-240K	Machine Model	DJ-240K
计量方法	量杯计量	Measurement method	Measuring cup
计量范围	0-100ml 跟换不同重量模具	Measuring range	0-100ml (change measuring cup)
包装速度	40 -80 bag/min 根据客户物料特性	Packing speed	40 -80 bag/min (according to material specific)
制袋尺寸	宽W:30-120 mm 跟换不同尺寸模具 长L:30-170 mm	Bag size	W: 30-120 mm (change different bag former) L: 30-170 mm
包装材料	Paper/PE, PET/AL, Foil/PE Nylon/PE, Tea-leaf filtering paper, etc.	Packaging material	Paper/PE, PET/AL, Foil/PE Nylon/PE, Tea-leaf filtering paper, etc.
总功率	1400W	Total power	1400W
电源电压	380V或220V	voltage	380V or 220V
重量	150KG	Weight	150KG
外型尺寸	625*750*1560 mm	Dimensions	625*750*1560mm

简要说明及特点 Brief instruction

适用于细小颗粒物料，洗衣粉，水精灵，调味粉的包装。全自动完成原料送料，称重计量，充填制袋，充气 / 排气，打印日期，成品输送的全部过程；计量精度高、效率高、不碎料。

Suitable for fine particle material, washing powder, water wizard, seasoning powder packaging. The system will finish all the process automatically: feeding, dosing, filling, sealing, date printing and finish product conveying. It has the advantages of high accurate weighting, high efficiency without broken material

主要特征 Main Features

- 包装袋适应范围广：对于单层PE、PE复合材质、CPP复合材质、铝箔等材质多层复合制成的预制袋。
- 包材损耗低：本机使用的是预制袋，包装袋图案完美，封口质量好，从而提高了产品档次。
- 快速更换包装规格：机械手装置的轻松快捷调节。
- Bags wide adaptation: For single PE, PE composite material, CPP composite materials, aluminum foil and other materials made of prefabricated multilayer composite film bags.
- Low packing material loss: This machine uses preformed bag, the bag pattern is perfect, good sealing quality, resulting in improved product quality.
- Quick-change bag size: robotic device quick and easy adjustment.



DJ-Z6(250)

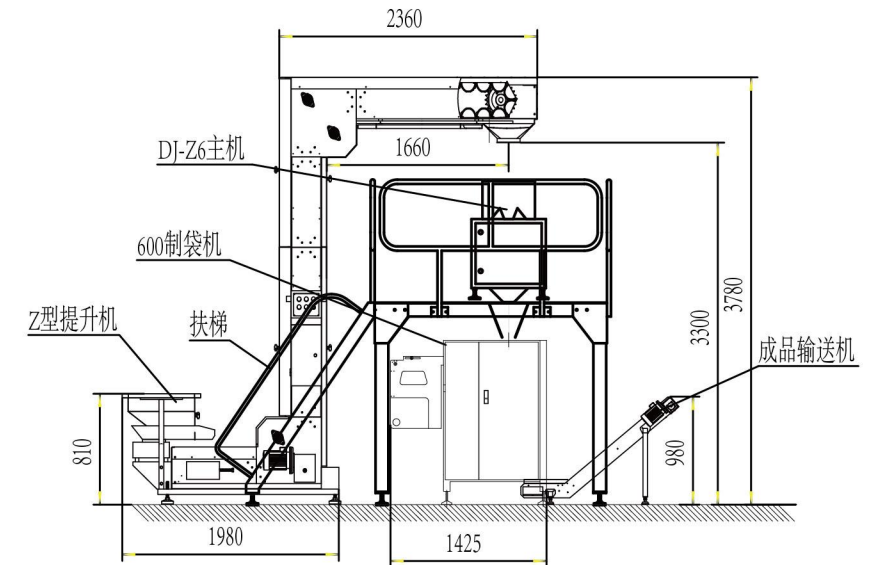

技术参数 Technological parameters

型号 Model	DJ-Z6(420)	DJ-Z6(520)
制袋尺寸 Making bag size	(L)60-300mm, (W)60-200mm	(L)80-350mm, (W)80-250mm
包装速度 Packing Speed	25-65Bags/Min Depend on the packing weight	25-65Bags/Min Depend on the packing weight
电源 Power Supply	220V, 50-60Hz, 3.0 Kw	220V, 50-60Hz, 3.6Kw
压缩空气 Compressed air consumption	6-8 kg/m2 ~0.3 m3/min	6-8 kg/m2~ 0.3 m3/min
重量 Weight	500 Kg	700 kg
尺寸 Dimension	1450×1000×2800 (mm)	1450×1100×3000 (mm)

简要说明及特点 Brief instruction

该机全自动完成原料送料, 称重计量, 充填制袋, 充气/排气, 打印日期, 成品输送的全部过程: 计量精度高, 效率高, 不碎料, 适用于细小颗粒物料到大颗粒物料, 如洗衣粉, 白糖, 花生, 膨化食品, 糖果, 速冻食品等的包装。

The machine fully automatic material feeding, weighing measurement, filling bag making, inflation / exhaust, printing date, finished product delivery process; high measurement accuracy, high efficiency, no scrap, suitable for small granular materials to large granular materials, such as washing powder, sugar, peanuts, puffed food, candy, frozen food, etc.

主要特征 Main Features

- 中英文触摸屏显示, 操作直观, 简单。
- PLC电脑控制系统, 运行更稳定, 可不停机调整任何参数。
- 可储存十组参数, 更换品种更准确。
- 采用伺服电机拉模, 定位更准确。独立温控系统, 精确度可达±1℃度。
- 横、纵封温度独立控制, 能良好的适用各种复合膜、PE膜等包装材料。
- 包装的款式多样化, 可供客户选择, 背封、插角、连袋、冲孔等。
- 生产制袋, 封口、包装、打印日期一次性完成。工作环境清洁, 噪音小。
- Chinese/English is displayed in touch screen, easy to be operating.
- Use PLC control system to makes work more fast and steadily, you can change the parameter during the machine still working.
- You can store ten kinds of parameters to make the changing more precision.
- Use servo motor, the locate is more precision. Independent temperature control system, the accuracy is between±1℃
- Two dinds of seals' have independent temperature control system, suitable for all kinds of compound roll film and PE roll film or other packing materials.
- Suitable for many kinds of packing styles, back seal and continuous seal and so on.
- Producing, sealing, packing, print the date can be done in one time. The condition of working is clean and low noise.



DJ-10D(250)

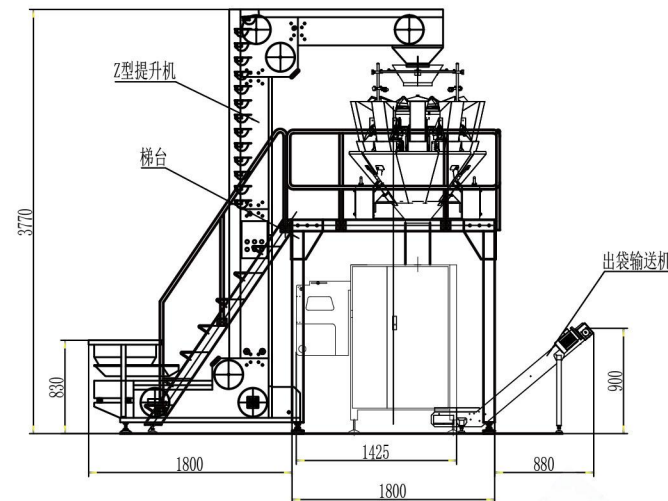

技术参数 Technological parameters

机 型	DJ-10D(250)	Type	DJ-10D(250)
制袋长度	100-350mm(L)	Bag Length	100-350mm(L)
制袋宽度	100-250mm(L)	Bag Width	100-250mm(L)
包装速度	40-50bag/min	Packing Speed	40-50bag/min
气 压	0.65mpa	Air Consumption	0.65mpa
耗气量	0.15m ² /min	Power Voltage	0.15m ² /min
电 压	220V 50-60HZ	Gsa Consumption	220V 50-60HZ
功 率	3.0KW	Power	3.0KW
外型尺寸	(L)1450mm×(W)1000mm×(H)1500mm	Dimension	(L)1450mm×(W)1000mm×(H)1500mm
机器重量	540kg	Total Weight	540kg

简要说明及特点 Brief instruction

这套设备由给袋式自动包装设备与组合称、上料机及配套而成, 主要适用于: 膨化食品, 速冻产品, 糖果, 饼干, 花生, 宠物食品等颗粒物料。
This set of equipment is made up of bag-type automatic packaging equipment and combination weighing and loading machine. It is mainly used for: puffed food, quick-frozen products, candy, biscuits, peanuts, pet food and other granular materials.

主要特征 Main Features

- 包装袋适应范围广: 对于单层PE、PE复合材质、CPP复合材质、铝箔等材质多层复合制成的预制袋。
- 包材损耗低: 本机使用的是预制袋, 包装袋图案完美, 封口质量好, 从而提高了产品档次。
- 快速更换包装袋规格: 机械手装置的轻松快捷调节。
- Bags wide adaptation: For single PE, PE composite material, CPP composite materials, aluminum foil and other materials made of prefabricated multilayer composite film bags.
- Low packing material loss: This machine uses preformed bag, the bag pattern is perfect, good sealing quality, resulting in improved product quality.
- Quick-change bag size: robotic device quick and easy adjustment.



DJ-GDK200

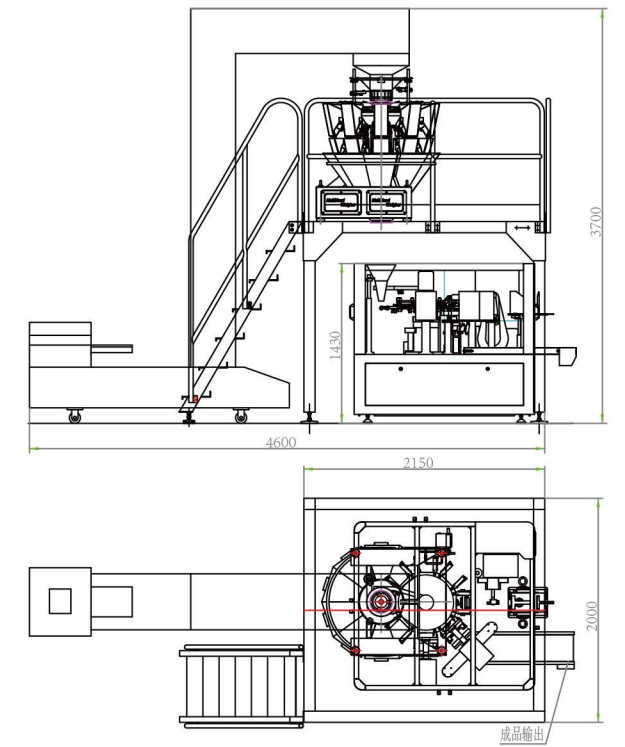

技术参数 Technological parameters

封口方式	自立袋, 平面袋 (三边封、四边封、手提袋、纸袋、复合袋)	Sealing Type	Stand-up pouch, flat bag (three-side seal, four-side seal, tote bag), paper bag, etc.
包装尺寸	W: 80-200mm L: 100 ~ 300mm	Packaging size	W: 100 -200mm L: 100 - 300mm
包装重量	10-2000g	Packing Weight	10-2000g
包装速度	20-50bag/min (具体速度由物料自身及填充重量决定)	Packaging speed	20-50bag/min (according to material itself and the filling weight)
包装精度	≤±0.5-2%	Packaging precision	≤±0.5-2%(according to material itself and the filling weight)
使用电源	三相 380V、50/60Hz	Power supply	Three-phase 380V, 50/60Hz
总 功 率	4.5KW	Total power	4.5KW
压缩空气	0.6m ³ /min(由用户提供)	Compressde Air Consumption	0.6m ³ /min
外型尺寸	2000×2000×3800mm	Dimension (mm)	2000×2000×3800mm

简要说明及特点 Brief instruction

该机应用范围广泛。颗粒和粉末均可真空成型和包装，适用于大米、杂粮、木薯球、茶叶、烤坚果、酵母等。
This equipment has a wider range of applications. Both granules and powders can be vacuum shaped and packaged. The machine is suitable for rice, miscellaneous grains, tapioca balls, tea, roasted nuts, yeast, etc.

主要特征 Main Features

- 包采用西门子PLC控制系统，实现机电一体化，操作方便简单。
- 智能称重控制方式，机器自动调整参数。
- 本机与物料或包装袋接触的部件及主机架部件均采用304不锈钢或其他符合食品卫生要求的材料，确保食品卫生安全。
- 自动检测、信息反馈等功能。
- 安全装置，当工作气压异常或加热管出现故障时，会发出警报。
- Siemens intelligent touch screen control system is adopted. Achieve electromechanical integration, and the operation is convenient and simple.
- Intelligent weighing control mode, the machine automatically adjusts parameters.
- The parts and main frame parts of this machine in contact with materials or packaging bags are all made of 304 stainless steel or other materials that meet food hygiene requirements to ensure food hygiene and safety.
- The packaging machine implements automatic detection, information feedback and other functions.
- Safety device, when the working air pressure is abnormal or the heating pipe fails, it will give an alarm.



DJ-VAC240



技术参数 Technological parameters

型号	DJ-VAC240	Machine Model	DJ-VAC240
计量方式	净重称量	Metering Mode	Net weighing mode
包装重量	0.5-5kg	Package Weight	0.5-5kg
包装精度	1-2g	Package Accuracy	1-2g
包装尺寸	W: 100-500mm L: 100-600mm	Packing Bag Size	W: 100-500mm L: 100-600mm
封口方式	自立袋、平面袋 (三边封、四边封、手提袋、纸袋、复合袋)	Suitable Bag Type	Stand-up pouch, flat bag (three-side seal, four-side seal, tote bag, paper bag, composite bag)
包装速度	600-900包/小时	Packaging Speed	600-900 Bags/H
电源	380V/220V	Power Supply	380V/220V
整机功率	7kW	Total Power	7kW
压缩空气	0.4-0.6MPa 24m3/h	Compressed Air Consumption	0.4-0.6MPa 24m3/h
外形尺寸	1600*2400*3700mm	Overall Dimensions	1600*2400*3700mm

简要说明及特点 Brief instruction

适用范围：适用于食品，医药，化工产品中液体物料的自动包装。如：农药剂、洗发水、沐浴液、面霜、调味酱、果酱、番茄酱、蜂蜜等液体物料。
Application: The machine is suitable for automatic packaging liquid foods in medicine and chemical industry such as pesticide shampoo, body foam bath lotion, facial cream, ingredient oil, fruit sauce, tomato ketchup and honey etc.

主要特征 Main Features

- 可在包装过程中自动完成充填、计量、制袋、封口、切断、热压、批号等全部工作，光电跟标定位无需调整。
- 智能控制系统、触摸屏操作界面。只需设定参数即可精确控制系统运作。
- 热封器对袋边均匀加热控制，上下两侧可单独调温。
- 更换刀具可实现一字形、花纹形切断、一字形连带切断，切袋平稳可靠不卡袋，操作简单，可配置轮式打码机，进行排打批号、保质期等
- Can be done automatically from packaging filling, metering, bag-making, sealing, cutting, pressing, lot number. All work with standard photoelectric positioning without adjustment.
- Intelligent control systems, English LCD display. Simply set the parameters can be precisely controlled system operation.
- Sealing the bag side pairs uniform heating control, on both sides of the upper and lower thermostat separately.
- Replace the tool can achieve a shape, pattern-shaped cut, cut a shape joint, smooth and reliable cutting bags are not card pockets, easy to operate, can be configured wheeled coders, were ranked batch number, shelf life, etc



DJ-240Y

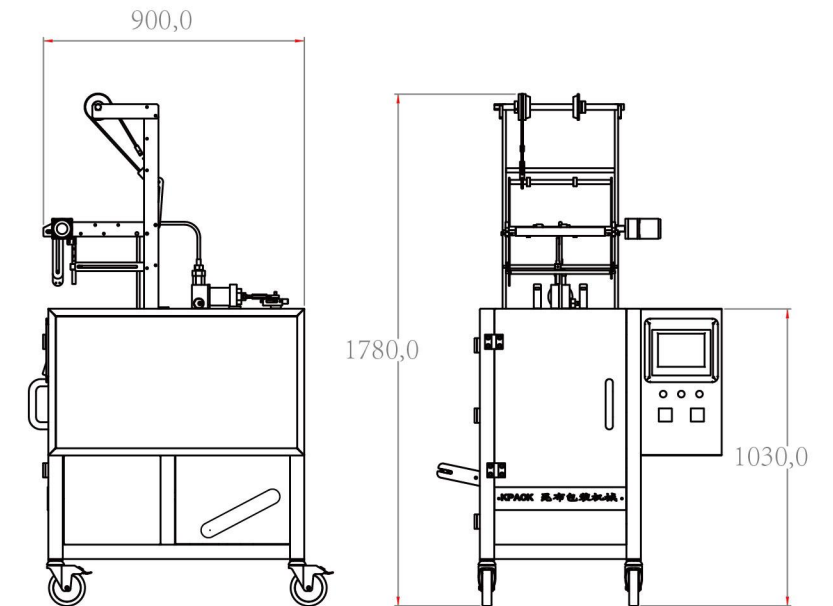

技术参数 Technological parameters

型号	DJ-240Y	Model	DJ-240Y
计量方法	计量泵	Measurement method	Liquid pump /paste pump
计量范围	0-100 ml	Measuring range	0-100 ml
包装速度	25-60包/分钟 根据用户物料特性	Packing speed	25-60bags/min according to pack material
制袋尺寸	宽(W):30-120 mm跟换不同尺寸模具 长(L): 30-155mm	Bag size	W:30-120 mm(change bag former) L: 30-155mm
总功率	1400W	Total power	1400W
电源电压	380V或220V或定制	voltage	380V or 220V
重量	150kg	Weight	150kg
外型尺寸(L*W*H)	625*750*1560 mm	Dimensions (L*W*H)	625*750*1560mm
备注	304不锈钢材质	remark	304 stainless steel

简要说明及特点 Brief instruction

广泛适用于食品、医药、化工行业如：豆沙馅、莲蓉馅、鱼肉馅、水果馅、冬瓜馅、水果酱料、花生酱、辣椒酱、沙拉酱、奶酪、酱油、白酒、花生、矿泉水、药液等以及非食品洗涤剂、润滑油等流体、半流体的自动定量包装。该包装机可以包装多种物料。袋长可以任调，当要包装多种包装规格，袋宽不定时，可以根据袋子的包装规格及重量，配置多套不同包装规格的成型器。此包装机也可选配不同的物料输送泵，特别适物体在高温状态下的自动定量充填包装，能有效的提高生产效率，避免因细菌入侵而造成的二次污染。可配套我司冷却式输送水槽降温设备、整形吹干机、上料机、输送带等流水线设备进行生产，节省生产时间，从而提高整体生产效率。

It is widely used in packing filling of sweetened bean paste, filling of lotus meat, fruit jam, Chinese watermelon jam, cheese jam, sauce, salad, lotion, liquid, semi liquid. Equipped with input pump, the machine could automatically pack the products in high temperature that will improve the productivity, decrease the cost, and avoid making the twice packing.

主要特征 Main Features

- 该包装机采用皮带牵引拉膜；牵引结构采用伺服电机，定位精度高，易于调整；
- 采用PLC伺服系统、气动控制系统、超大显示触摸屏构成驱动 控制核心；最大限度提高了整机的控制精度、可靠性和智能化程度；
- 触摸屏能储存多种不同产品的包装工艺参数，当更换产品时可随时使用无需重新设定；
- 可以不停机直接在触摸屏上调整封切位置，纠偏等；带有自动报警功能，如门未关、无卷膜、无色带等；
- 该机适合做枕式包、立袋、连包装、手拎袋。
- The packaging machine adopts belt traction film: the traction structure adopts servo motor, and the positioning accuracy is easy to adjust;
- The horizontal seal adopts high-power servo motor, the transverse seal pressure and the open stroke can be adjusted at any time, suitable for various packaging materials;
- Touch screen can store the technical parameters of various kinds of products, no need to reset while products changing.
- It can adjust the sealing and cutting position, correcting deviation, etc directly on the touch screen without stopping the machine;
- With automatic alarm function, such as door not closed, no film, no ribbon, etc.;
- This machine is suitable for Pillow bag, Triangle bag, Chain bag, Hole bag.



DJ-530Y

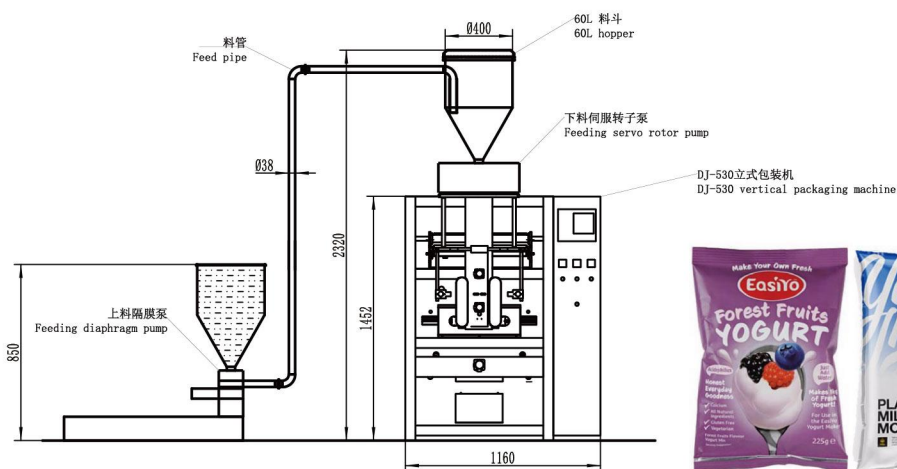

技术参数 Technological parameters

型号 Model	DJ-530Y	DJ-630Y
制袋尺寸 Making bag size	W:100-250mm L:150-480mm	W:100-290mm L: 150-600mm
卷膜宽度 Film width	220-560mm	220-620mm
包装材料 Packing material	复合薄膜 (NY/PE 等) Composite film NY/PE ect	
包装速度 Packing speed	4-10 包 / 分 (与充填重量有关) 4-10bags/min (Depend on packing weight)	
包装容量 Packing volume	Max.5000cc	Max.10000cc
包装形式 Sealing type	背封封口	
电源 Power supply	AC 380V 50Hz	
功率 Power	4.5KW	
气源 Air pressure	0.6-0.8 Mpa .0.006m3/min	
外形尺寸 Dimension	L1350mm * W980mm * H 1980mm	L1350mm * W1080mm * H2150mm
重量 Weight	450Kg	550kg

简要说明及特点 Brief instruction

这套设备由给袋式自动包装设备与液体、膏体灌装机配套而成。主要适用于：洗涤剂、黄酒、酱油、米醋、果汁、饮料、火锅底料、番茄酱、花生酱、果酱、辣椒酱、豆瓣酱等物料的自动计量。

This device consists of a automatic bag packaging machines and liquid filling machine. Mainly applies to: detergents, yellow sprinkles, soy sauce, vinegar, juice beverage, pot bottom material, ketchup, peanut butter, jam, chill sauce bean paste and other materials, automatic weighing and packing.

主要特征 Main Features

- 包装袋适应范围广：对于单层PE、PE复合材质、CPP复合材质、铝箔等材质多层复合制成的预制袋。
- 包材损耗低：本机使用的是预制袋，包装袋图案完好，封口质量好，从而提高了产品档次。
- 快速更换包装规格：机械手装置的轻松快捷调节。
- Bags wide adaptation: For single PE, PE composite material, CPP composite materials, aluminum foil and other materials made of prefabricated multi layer composite film bags.
- Low packing material loss: This machine uses preformed bag, the bag pattern is perfect, good sealing quality. resulting in improved product quality.
- Quick-change bag size: robotic device quick and easy adjustment.



DJ-GDY200

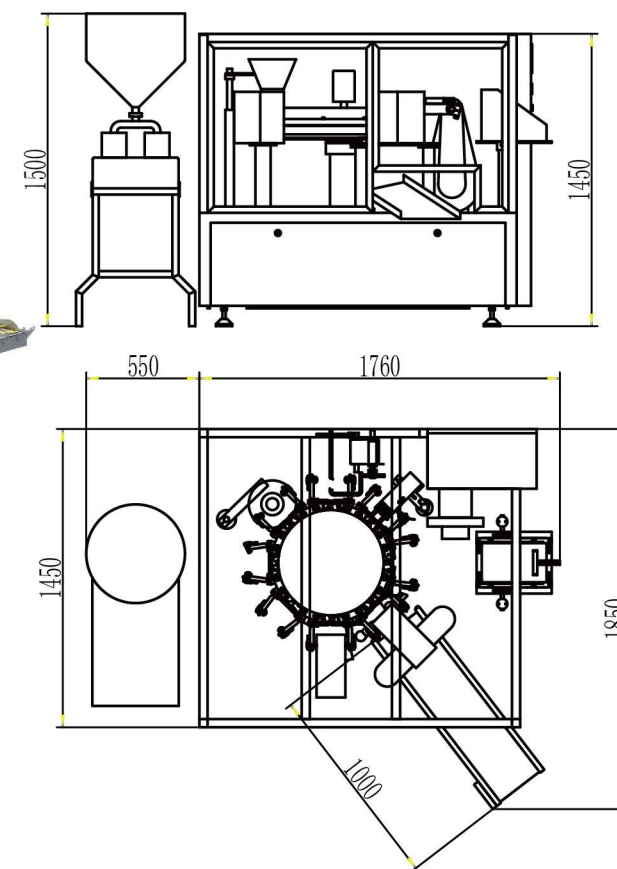

技术参数 Technological parameters

型号 Model	DJ-GDY200 Automatic particle rotary pack machine
封口方式 Sealing Type	Stand-up pouch, flat prefabricated pouch
包装尺寸 Packaging size	W: 80-200mm L: 100 ~ 300mm
包装重量 Packing Weight	100-1000g
包装速度 Packaging speed	20-50bag/min (depend on material specific and weight.)
包装精度 Packaging precision	About ±1%
使用电源 Power supply	3P 380V、50/60Hz
总功率 Total power	3KW
压缩空气 Air Consumption	0.6m3/min
外型尺寸 Dimension (mm)	2250×1500×1500mm

专门针对粉末状、超细粉末状等物料而设计制造，该机能完成计量、充填等工作，通过伺服电机带动螺杆旋转达到计量充填物料的目的。能够与各种制袋包装机配套。适用于易流动或流动性极差的粉粒状物料，如奶粉、蛋白粉、米粉、奶茶、固体饮料、咖啡粉、白砂糖、食品添加剂、饲料、农药、医药原料、味精、调味品、葡萄糖、染料、香精香料等物料。

This machine is specially designed and manufactured for powdery and superfine powdery materials. It can do dosing and filling work, Auger is driven by servo motor to dosing and filling. It can be used with various bag making and packaging machines. Suitable for packaging milk powder, protein powder, rice flour, milk tea, solid beverage, coffee powder, white sugar, food additives, feed, pesticides, pharmaceutical raw materials, monosodium glutamate, seasonings, glucose, dyes, flavors and fragrances.



- 型号/Model: DJ-3A
- 螺杆直径/Auger diameter: 直径17-46
- 充填重量/Filling weight: 10-500g
- 充填速度/Filling speed: 10-80包/分
- 充填精度/Filling accuracy: $\pm 0.3-1\%$ (According to material proportion and pack weight)
- 充填扭矩/Torque: 2.39N.m
- 电源/Power supply: 380V/220V 50-60Hz
- 整机功率/Total power: 1.2kw
- 整机重量/Total weight: 110kg
- 整机体积/Machine size: 600×500×1000mm
- 料箱容积/Hopper volume: 25L



- 型号/Model: DJ-3A+ 不锈钢Stainless Steel
- 螺杆直径/Auger diameter: 直径17-46
- 充填重量/Filling weight: 10-500g
- 充填速度/Filling speed: 10-80包/分
- 充填精度/Filling accuracy: $\pm 0.3-1\%$ (According to material proportion and pack weight)
- 充填扭矩/Torque: 2.39N.m
- 电源/Power supply: 380V/220V 50-60Hz
- 整机功率/Total power: 1.2kw
- 整机重量/Total weight: 130kg
- 整机体积/Machine size: 600×500×1000mm
- 料箱容积/Hopper volume: 25L



- 型号/Model: DJ-3B
- 螺杆直径/Auger diameter: 直径22-84
- 充填重量/Filling weight: 50-3000g
- 充填速度/Filling speed: 10-80包/分
- 充填精度/Filling accuracy: $\pm 0.3-1\%$ (According to material proportion and pack weight)
- 充填扭矩/Torque: 5-10N.m
- 电源/Power supply: 380V/220V 50-60Hz
- 整机功率/Total power: 1.8kw
- 整机重量/Total weight: 180kg
- 整机体积/Machine size: 750×800×1100mm
- 料箱容积/Hopper volume: 50L



- 型号/Model: DJ-3B+ 不锈钢Stainless Steel
- 螺杆直径/Auger diameter: 直径22-84
- 充填重量/Filling weight: 50-3000g
- 充填速度/Filling speed: 10-80包/分
- 充填精度/Filling accuracy: $\pm 0.3-1\%$ (According to material proportion and pack weight)
- 充填扭矩/Torque: 5-10N.m
- 电源/Power supply: 380V/220V 50-60Hz
- 整机功率/Total power: 1.8kw
- 整机重量/Total weight: 200kg
- 整机体积/Machine size: 750×800×1100mm
- 料箱容积/Hopper volume: 50L

全密封、组合式/全不锈钢侧开门料箱、出料口吸尘、机械或油压升降。
Fully sealed, combined type /All SUS side-open hopper, dust removal at the outlet, mechanical or hydraulic lift.

简要说明及特点 Brief instruction



- 型号: DJ-S1
- 加料速度: 1立方米/小时
- 料箱容积: 110升
- 电源: 三相380V 50Hz
- 整机功率: 驱动电机550W; 振动电机68W
- 整机重量: 80Kg
- 下料口距地面高度: 1.6米
- Model: DJ-S1
- Capacity: 1m³/h;
- Machine weight: 80Kg;
- Hopper size: 100L
- Machine Power: 600W
- Conveyor Height: 1600mm from floor
- Power Supply: 380 V Three-phase 50-60 Hz



- 名称: 螺旋上料机(专利产品)
- 型号: DJ-S3 (圆斗)
- 提升量: 3-5m³/小时
- 料箱容积: 230升
- 上料高度: 1870mm
- 电源: 380/220V 50-60Hz
- 备注: 可订制其它规格
- Name: Auger conveyor (Patented product)
- Model: DJ-S3 (Round)
- Lift capacity: 3-5m³/h
- Hopper size: 230L
- Conveyor height: 1870mm
- Power supply: 380/220V 50-60Hz
- Remarks: Other size optional



- 横向螺旋给料机 料仓双螺旋给料Horizontal Auger Feeding
- 型号/Model: DJ-H1
- 输送速度/conveying capacity: 1-3m³/H
- 管径/Diameter of pipe: 89-159mm
- 电源/Power supply: 380V/220V 50-60Hz
- 整机功率/Total power: 0.4-0.75kw
- 整机重量/Total weight: 40-100kg
- 输送长度/Conveying length: 0.8-5m



名称: 真空上料机 Name: Vacum conveyor

型号 Model	输送量(kg/h) Conveyor capacity	整机功率(kw) Total power
BSQ-X1	400	1.5
BSQ-X2	600	2.2
BSQ-X3	1200	3
BSQ-X4	2000	5.5
BSQ-X5	3000	4
BSQ-X6	4000	5.5
BSQ-X7	6000	5.5

卧式螺旋混合机由U形容器、螺旋搅拌叶片和传动部件组成；螺旋状叶片为双层结构，外层螺旋将物料从两侧向中央汇集，内层螺旋将物料从中央向两侧输送，形成对流混合。螺旋混合机对于粘性或有凝聚性的粉粒体的混合以及粉粒体中添加液体及糊状物料的混合有良好的效果，筒盖可做全开式门，以便于对设备进行清洗更换产品。

The Horizontal Ribbon Mixer consist of U-Shape tank, spiral and drive parts. The spiral is dual structure. Outer spiral make the material move from the sides to the center of the tank and the inner screw conveyor the material from the center to the sides to get the convective mixing. Our DP series Ribbon mixer can mix many kinds material especially for the powder and granular which with stick or cohesion character, or add a little liquid and paste material into powder and granular material. The mixture effect is high. The cover of the tank can be made as open in order to cleaning and change parts easily.



螺旋混合机

型号Model	DH-JD-200	DH-JD-300	DH-JD-500	DH-JD-1000	DH-JD-1500	DH-JD-2000
有效容量Volum	200L	300L	500L	1000L	1500L	2000L
全容积Total volum	284L	404L	692L	1286L	1835L	2475L
转速Turn speed	46rpm	46rpm	46rpm	46rpm	46rpm	46rpm
整机重量Weight	250kg	350kg	500kg	700kg	1000kg	1300kg
整机功率Powder	4kw	5.5kw	7.5kw	11kw	15kw	22kw
总长Length	1370	1550	1773	2394	2715	3080
总宽Width	834	970	1100	1320	1397	1625
总高Height	1647	1655	1855	2187	2313	2453
电源Powder	3P AC208-415V 50/60Hz					

TDW无重力混合机又称桨叶混合机，适用于粉料与粉料、颗粒与颗粒、颗粒与粉料及添加少量液体的混合，广泛应用于食品、化工、干粉砂浆、农药、饲料及电池等行业。该机是高精度混合设备，对混合物适应性广，对比重、配比、粒径差异大的物料能混合均匀，对配比差异达到1:1000~10000甚至更高的物料能很好的混合。本机增加破碎装置后对颗粒物料能起到部分破碎的作用，材质可选316L，304，201，碳钢等。

TDW non gravity mixer is called double-shaft paddle mixer too, it is widely applied in mixing powder and powder, granule and granule, granule and powder and a bit liquid. It is used for food, chemical, pesticide, feeding stuff and battery etc. It is high precision mixing equipment and adapts to mix different sizes of materials with different specific gravity, the proportion of formula and mixing uniformity. It can be a very good mix for which ratio reaches 1:1000~10000 or more. The machine can make the partial of granules broken after crushing equipment added.



双桨叶混合机

型号Model	TDW-300	TDW-500	TDW-1000	TDW-1500	TDW-2000	TDL-3000
有效容量Volum	300L	500L	1000L	1500L	2000L	3000L
全容积Total volum	420	650	1350	2000	2600	3800
装载系数Loading factor	0.6-0.8	0.6-0.8	0.6-0.8	0.6-0.8	0.6-0.8	0.6-0.8
转速Turn speed	53rpm	53rpm	45rpm	45rpm	39rpm	39rpm
整机重量Weight	660kg	900kg	1380kg	1850kg	2350kg	2900kg
整机功率Powder	5.5kw	7.5kw	11kw	15kw	18.5kw	22kw
总长Length	1750	1880	2250	2470	2550	2800
总宽Width	1150	1180	1470	1660	1780	1980
总高Height	1280	1350	1600	1800	1860	1980
筒体半径Radius(R)	277	307	377	450	485	534
电源Powder	3P AC208-415V 50/60Hz					

TDWK无重力开门式混合机又称抽拉式桨叶混合机。该设备是我公司在混合机领域长期实践基础上，为了克服卧式混合机清理不便的缺点，采用了齿轮减速机与混合机转子直连传动，两根搅拌轴可以随齿轮箱移出搅拌仓。从而更加方便人工清洗。可靠性更高，使用寿命更长。适用于粉料与粉料、颗粒与颗粒、颗粒与粉料及添加少量液体的混合，广泛应用于食品、化工、干粉砂浆、农药、饲料及电池等行业。

TDWK non-gravity open-door mixer is also called pulling type paddle mixer. On the basis of long-term practice in the field of mixer, this series machine overcomes the drawback of horizontal mixer to clean up inconveniently. The gear reducer and mixer rotor are direct transmission, The two mixing shaft move out from mixer tank that powered through gear box. It's more convenient to cleaning equipment by workers. higher reliability and longer service life. It is widely applied in mixing powder and powder, granule and granule, granule and powder and a bit liquid. It is used for food, chemical, pesticide, feeding stuff and battery etc.



抽拉式混合机

型号Model	DJ-300	DJ-500	DJ-1000	DJ-1500
有效容量Volum	300L	500L	1000L	1500L
全容积Total volum	420	650	1350	2000
装载系数Loading factor	0.6-0.8	0.6-0.8	0.6-0.8	0.6-0.8
转速Turn speed	53rpm	53rpm	45rpm	45rpm
整机重量Weight	2200kg	2500kg	3000kg	3500kg
整机功率Powder	5.5kw	7.5kw	11kw	15kw
总长Length	3050	3300	3960	4380
总宽Width	1150	1180	1470	1660
总高Height	1400	1480	1760	2000
电源Powder	3P AC208-415V 50/60Hz			

集吸/混合/发送功能为一体的三合一设备。整机全不锈钢，特别适用GMP认证，食品卫生认证，要求抗腐蚀化工等产品的混合与输送。PLC触摸屏界面，工作稳定，抗干扰，操作便捷直观，各阶段控制的参数均可自由更改。共两种进料方式可供选择使用，进出口等管口方向可以根据需要自由变更。耳座处可增配3个称重传感器，进行物料称重。可满足对粉体小颗粒的混合，混合程度温和，不会破坏物料物理原始状态，混合效率高。排气口向下弯曲，减少排期时对屋顶的影响。设备结构简单，维护方便，各工作配件均为标准件，方便购买。

This machine integrates suction, mixing and transmission functions. This machine is made of stainless steel, conforms to GMP standard and food hygiene standard, it can be used for mixing and conveying in anti-corrosion industry. It has PLC and touchscreen, stable working, anti-interference, easy operation, parameters can be configured. Two feeding mode are available, the direction of import and exprot can be adjusted according to the actual situation. The material is weighed by 3 sensor on the mechine. It is suitable for mixing powder and small particles, good mixing degree, the physica original state of the material will not be destory. The exhaust pipe bends downward to reduce impact on the ceiling. The equipment is simple in the structure and convenient to maintain, all work parts are standard parts, easy to buy and replace.

气力混合机



型号Model	BHQ-0.18	BHQ-0.38	BHQ-1.2	BHQ-2.3
容量Volum	0.18m ³	0.38m ³	1.2m ³	2.3m
装载系数 Load factor	50%-70%			
尺寸 Machine size	1100*950*2400	1200*1050*2700	2600*1900*3800	2900*2300*4300
整机功率 Power	380V/1kw			
用气量 Gas Consumption	0.5-0.8MPa (≤3um)40m ³ /H	0.5-0.8MPa (≤3um)960m ³ /H	0.5-0.8MPa (≤3um)1120m ³ /H	0.5-0.8MPa (≤3um)150m ³ /H
重量 罐体 Jar	230kg	280kg	650kg	900kg
重量 框架 Frame	100kg	140kg	500kg	600kg

简要说明及特点 Brief instruction

DJ-DP1000



本机将一层一层的空罐送到理罐机上，应用于马口铁罐、纸罐及铝罐的空罐卸垛作业，本机使用伺服电机升降，定位准确。中英文触摸屏人机界面，PLC控制系统，可储存10个配方提取数据方便直观，操作简单。

This machine put many layer of empty tank to tank engine, used in tinplate cans, paper cans and aluminum cans cans Depalletizing operation. This machine uses servo motor lifting, positioning accuracy. Middle English touch screen man-machine interface, PLC control system, can store 10 formula extracted data is convenient and intuitive, simple operation.

- 设备名称：卸垛机
- 卸垛能力：2-3垛/分钟
- 适用罐规格：直径60-150mm 高80~200mm
- 整机功率：1.2KW
- 适用最大罐垛：(长*宽*高)1300*1300*1500mm
- 外型尺寸：(长*宽*高)4500*2000*2400
- The depalletizing capacity: 2-3 Crib / min
- Application of tank specification: D60-150mm high 80-200mm
- Machine power: 1.2KW
- Applicable to the largest tank stack: (length * width*height)1300*1300*1500mm
- Dimensions: (length * width* height)4500*2000#2400

DJ-LG1000



- 名称：理罐机
- 理罐能力：80罐/分
- 电源：380/220V 50-60Hz
- 功率：180W
- Name: Cans Unscrambler
- Unscrambling cans capacity: 80cans/m
- Power supply: 380/220V 50-60Hz
- Power: 180W

DJ-SJ1000

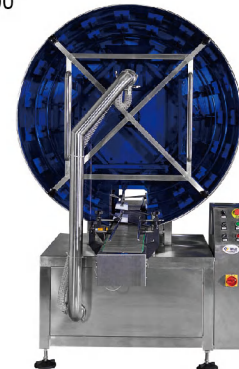

- 名称：无磁空罐杀菌机
- 清洁速度：≤40罐/分钟
- 清洁方式：气吹，紫外线灯杀菌，吸尘
- 电源：三相380V 50-60Hz 380V
- 整机功率：电机0.75kw
- 整机重量：200Kg
- 外型尺寸：2450×1500×2330mm
- Name: Non-magnetic empty can sterilizing machine
- Clean speed: ≤40 cans/min
- Clean way: ultraviolet virus
- Power supply: three phase 380V 50-60Hz 380V
- Total power : 0.75kw
- Total weight: 200kg
- Overall dimenxions: 2450×1500×2330mm

DJ-TS40



本机是自主设计制造的专业设备，是粉体罐装生产线的配套设备，用于自动给勺；采用振动盘理勺，勺子自动排序，传感器检测，可实现无罐、无勺自动停机；理勺速度快、能耗小、结构简单；符合国家GMP标准，采用SUS304不锈钢制造。

This is our own design automatic scoop feeding machine can be integrated with other machines in powder production line. Featured with vibrating scoop unscrambling, automatic scoop sorting, scoop detecting, no cans no scoop system. Low power consumption, high scooping and simple design

- 工作方式：振动盘理勺，气动给勺
- 给勺速度：40-60只/分钟
- 电源供应：3P AC208-415V 50/60Hz
- 整机功率：0.37KW
- 外形尺寸：1500×700×1500mm
- Working mode: Vibrating scoop unscrambling machine, Pneumatic scoop feeding machine.
- Casting speed: 40-80pcs/min
- Power supply: 3P AC220V 60Hz
- Total power: 0.37kw
- Overall dimension: 1500*700*1500mm

简要说明及特点 Brief instruction

DJ-GQ100罐周清洁机



本机能对罐周、罐顶及罐底进行全方位吹扫；上下两面采用脉冲风刀吹扫，配合吸尘装置，除静电于一体，清洁效果极好；全不锈钢结构，有机玻璃外罩，粉尘不外泄污染环境，设备结构简单容易操作；底部带除尘口，与除尘器对接，除尘器另购或客户自备。

This machine is used to provide all-round cleaning for cans outer body ; The top and bottom parts are cleaned by the blow-system and dust-collection device that produce excellent cleaning effect ; With stainless steel structure, plexiglass cover, to assure a clean work environment; With dust outlet at the bottom to connect with the dust cloecting system (self-owned)

- 工作速度：60罐/分钟
- 适应罐型：#300-#502
- 电源供应：3P AC208-415V 50/60Hz
- 整机功率：0.48kw
- 鼓风机功率：5.5kw
- 外形尺寸：1720*900*1260mm
- Cleaning Capacity:60 Cans/min
- Can specification: #300-#502
- Power supply:3P AC208-415V 50/60Hz
- Total power: 0.48kw
- Blower power:5.5kw
- Overall dimension:1720*900*1260mm

DJ-FG100翻罐器



本翻罐器采用尼龙制造.通过传送带把罐体送入螺旋内腔,使得罐体翻转至所需要的角度.从而起到罐体翻转作用.结构简单.耐磨性高.使用寿命长.

The tipping tank is made of nylon. Through the conveyor belt to the tank into the inner cavity of the tank body screw, turning to the desired angle, so that the tank body flip effect has the Vantages of simple structure, high wear resistance, long service life.

DJ-YG150胶盖压盖机



- 设备名称：胶盖压盖机
- 压盖速度：30-60Cans/min
- 适用罐规格：直径60-150mm, 离80-200mm (更换给盖横具)
- 整机功率：800w
- 压缩空气：6kg/cm² 0.3m³/min
- 主要材质：SS304不锈钢
- 外形尺寸：2400*650*1500mm
- Equipment Name: Rubber Cover Capping Machine
- Capping speed: 30-60 Cans/min
- Can specifications: diameter 60-150mm, from 80-200mm (replacement to cover cross)
- Machine power: 800w
- Compressed air: 6kg/cm² 0.3m³/min
- Main material: SS304 stainless steel
- Dimensions: 2400*650*1500mm

DJ-FG100全自动封罐机



全设备仅使用一台电机驱动，运行状态稳定。电气配件均使用一线产品，提升可靠性。PLC触摸屏界面，稳定抗干扰，设定简单快捷。全自动运行，盖子充足情况下无需人工操作。可更换封罐磨具，适合不同罐子尺寸。

The entire device is driven by only one motor and is stable in operation. Electrical accessories use first-line products to improve reliability. PLC touch screen interface, stable anti-interference, setting is simple and fast. Fully automatic operation without manual operation when the cover is sufficient. Replaceable cans and grinders for different can sizes.

- 罐体规格：502/401/307/300, 高度100-230mm
- 封装能力：25-30罐/min
- 整机尺寸：2000*900*1600mm
- 工位高度：850±50mm
- 整机重量：400kg
- 电源功率：380V/1.5KW
- 压缩空气：0-5~0.8MPa;洁净空气 (小于等于40gm) 1m³/H
- 主要材质：304不锈钢
- Tank specifications: 502/401/307/300, height 100 - 230
- Encapsulation capability: 25-30 cans /min
- Machine size: 2000 x 900 x 1600mm
- Position height: 850 + 50mm
- Machine weight: 400kg
- Power: 380V/ 1.5KW
- Compressed air :air clean 0.5 -0.8MPa (<40) 1m³/H
- Main material: 304 stainless steel

简要说明及特点 Brief instruction

DJ-VN100全自动抽真空充氮封罐机

适用范围奶粉、保健品、调味品、休闲食品等；
Applicable scope is milk powder, health products, condiments, snack food etc.



- 罐体规格：标准502/401/307罐高100~230mm
- 封装能力：6~8罐/min
- 残氧量：小于等于3%
- 氮气纯度：大于等于99.9%
- 整机尺寸：1800x760x1850mm
- 工位高度：850mm
- 整机重量：400kg
- 整机能耗：380V/4KW, 氮气4m³/H
- 压缩空气：0-5~0.8MPa;洁净空气 (<40gm) 1m³/H
- 主要材质：304不锈钢
- Tank specifications: 502/401/307, height 100 -230
- Encapsulation capability: 6-8 cans /min
- Residual oxygen: less than or equal to 3%
- Nitrogen purity: 99.9% or more
- Machine size: 1800x760x1850mm
- Position height: 850
- Machine weight: 400kg
- Power: 380V/ 1.5KW
- Compressed air :air clean 0.5 -0.8MPa (<40) 1m³/H
- Main material: 304 stainless steel

DJ-LC1000立式储料箱



储存量：0.25-2m³
规格：圆形方形可选
备注：除电机外，整机不锈钢制造，物料接触304不锈钢，可配搅拌、筛网、料位等。根据不同需求，可增加可视窗，人孔，清洁卫生简便，无死角，无残留，满足食品卫生要求。
Name: Vertical store tank
Store capacity: 0.25-2m³
Specifications: round square optional
Remarks: All made of stainless steel except motor, Contact parts SUS304.
Accessories and options: Stirrer, safety griddle net, level sensor.
It can increase the looking window, manhole, easy to clean, no dead angle, no residue, meet food hygiene requirements.

DJ-SJ5000大包杀菌机

DJ大包隧道杀菌机由全304不锈钢、吹扫装置、36支紫外线杀菌灯等组成。该杀菌机能完成杀菌、吹扫、产量累计等功能。可根据输送速度来调整杀菌强度，整机主要采用不锈钢结构。具有杀菌效果好、稳定性高、抗干扰强、耐腐蚀、方便清理、无卫生死角、外观美好、长寿命等特点，主要适用包装食品、医药等行业。

DJ large tunnel sterilizing machine consists of 304 stainless steel, a blowing device, 36 ultraviolet germicidal lamp, PLC control system etc.. The bactericidal function complete sterilization, purge, yield accumulated function.
Has good sterilization effect, high stability, strong interference resistance, corrosion resistance, easy to clean, without hygiene dead angle, the exterior is beautiful, long life and other characteristics, mainly for packaging food, medicine and other industries



- 工作方式：光轴链条带动输送
- 输送速度：0-8米/分钟
- 工作电压：三相380V 50Hz
- 整机重量：500Kg
- 整机体积：5000 (不含输送带) x 1200 x 1050mm
- 整机功率：2.5KW
- 吸尘器风量：200—300m³+00B3/h
- Way of working: roller conveyor
- Conveyor speed: 0-8meters / min
- Working voltage: 50Hz three-phase 380V
- Machine weight: 500Kg
- Machine size: 5000x 1200x1050mm
- Machine power: 2.5KW
- Cleaner air: 200—300m³+00B3/h

DJ-CC1500工业除尘器

含尘气体在压力作用下，经过进风口进入除尘器，此时气流扩张，流速降低会导致大颗粒粉尘在重力作用下从含尘气体中分离，掉落到集尘抽屉中。其余细微粉尘会随着气流方向粘附在滤芯外壁，再由振动装置进行清粉。净化后的空气穿过滤芯，过滤网布从顶端出风口排出。

The gas with powder goes into the dust collector through inlet hose under pressure, air expansion at this time, lower flow velocity will cause the large particles of powder separated from the gas with powder and falls into the dust drawer under the gravity. Other tiny powder is adhered to the filter's outer wall with the air flowing direction and then clean by the vibration device. After purification, the gas goes out from the top outlet through the filter and filter cloth.



型号 Model	DJ-1.5A	DJ-2.2A	DJ-3.0A	DJ-4.0A
处理风量 Handling air volume (m ³)	750-1050	1350-1650	1700-2400	2650-3500
压力 Air pressure (Pa)	940-690	960-580	1680-1100	1680-1100
总功率 Total power (KW)	1.62	2.32	3.12	4.12
设备最大噪音 Maximum noise (dB)	60	65	70	70
除尘效率 Dust removal efficiency (%)	99.9	99.9	99.9	99.9
总长 length	670	710	770	830
总宽 width	550	630	670	720
总高 height	1620	1740	1810	1880
滤芯尺寸 Filter diameter (mm)	325*600*1个	408*660*1个	325*600*2个	408*660*2个
设备重量 Total weight (Kg)	102	143	165	220

简要说明及特点 Brief instruction

DJ-ZXSJ100 直线空罐杀菌机 Straight line can sterilization machine



- 链板宽度:152mm
 - 传送速度:10m/min
 - 电源供应: 3P AC208-415V 50/60Hz
 - 整机功率:电机0.55KW, 灯 0.96KW
 - 整机重量:200kg
 - 外形尺寸:3200*400*1150mm
- Chain plate width:152mm
 - Conveying speed:10m/min
 - Power supply: 3P AC208-415V 50/60Hz
 - Total power:Motor:0.55KW, UV light:0.96KW
 - Total weight:200kg
 - Overall dimension:3200*400*1150mm

DJ-UC1000除尘振筛拆包台 (三合一投料站) Unpacking station



- 整机功率: 700W
 - 电源: 380V/220V 50-60HZ
 - 整机尺寸: 1500M 600x1700mm
 - 主要材质: 304不锈钢
- Machine power:700W
 - Source:380V/220V50-60Hz
 - Machine size: 1500x 1600 x1700mm
 - Main material:304 stainless steel

DJ-SS2400输送带 Conveyor



各种规格输送机, 链板式输送机、皮带输送机、无动力滚筒输送机、动力滚筒输送机、网带输送机, 可平送, 爬坡、转弯等, 所有输送设备护边、支架均采用不锈钢材料。

All kinds of conveyor:Chain plate conveyor, Belt conveyor, Roller Conveyor without conveying motor, Roller Conveyor with conveying motor, Mesh belt conveyor, can be designed per specific request, and so on.The rails and frame are made of stainless steel.

DJ-PT2000工作平台 Stainless Steel Platform



全不锈钢结构
包含平台、护栏和梯子
台面和梯子的面板均为不锈钢防滑板
平台可以设计成可拆式, 便于运输

Fully stainless steel structure.
Include:Platform,guard rails and ladder.
The surface of platform and ladder are made of checkered plate.
The platform can be made with detachable design,which is easy for moving.

DJ-600L 25kg抽真空封口机 DJ-600L 25kg vacuum sealing machine



本气动塑料薄膜大袋封口机在化工、粮食、食品、饲料等行业得到广泛应用。适用于封口长度小于800mm、重量小于50kg的塑料袋或复合袋的间歇包装封口。该机采用压缩空气作动力, 封口压力可调, 可以手动或通过脚踏开关操作

DJ-650 The machine is widely used in chemical industry,foodstuff,feedstuff industries to seal various plastic film bags and compound bag with max.sealing length of 600mm and max.carrying load of 50kg.It adopts compressed air as motive power with variable sealing pressure and reliable sealing quality.The sealing operation can be controlled by manual or through using pedal switch,featuring ease of operation.

封口长度 Sealing length	≤700mm
包装高度 Packing height	≤600mm
电 源 Power supply	380V
内腔空间 Inner cavity space	Φ450mm
整机功率 Machine power	2.25kw
整机重量 Machine weight	270Kg
整机体积 Machine size	850*800*1650
封口线 Sealing line	10mm*1
真空泵配置 Vacuum pump configuration	XD-020(3 or 2set)
极限真空度 Ultimate vacuum	1.0KPa
抽气速率 Pumping rate	60 m³/h or 40m³/h

简要说明及特点 Brief instruction

DJ-KX自动开箱机 Automatic carton opener



自动完成开箱、成形、下底折叶折曲,并现时完成下部分胶带粘贴,本机将叠成纸板的箱板自动打开,箱子底部按一定程序折合,并用胶带密封后输送给装箱机的专用设备。
The carton erector machine can finish the work of carton opening, shaping, folding and sticking the adhesive tape in the bottom of the carton.

型号 Model	DJ-KX
适用纸箱 Suit carton size	L:250-450 W:150-400 H:100-400(mm)
封箱速度 sealing speed	8-12 carton/min
台面高度 Table height	750±50mm
机械尺寸 Machine size	1700×1930×1500mm
使用电源 Power supply	220/380 50/60Hz
使用气源 Air use	5-6kg/cm³
使用胶带 Type width	48/60/72mm

DJ-ZX自动装箱机 Automatic carton filling

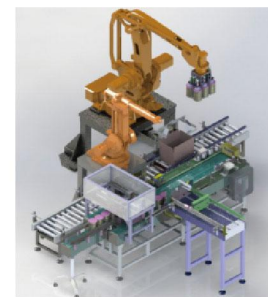

机器人装箱机应用范围广、占地面积小,性能可靠,操作简便,虽机身小巧,能集成于紧凑型包装机械中,却又能满足您在到达距离和有效载荷方面的所有要求。

The robotic case-packing machine has a wide range of applications, small footprint, reliable performance and easy operation. Although it is compact and can be integrated into a compact packaging machine, it can meet all your requirements for reach and payload.

机器型号 Model	DJ-ZX
电源/功率 Power	380V 50/60HZ 10KW
有效负载 Payload	30kg-250kg(Select robot according to customer needs)
装箱速度 Speed	10-40carton/min
装箱方式 work way	Single carton / multiple cartons
使用气源 Use air	6-7kg
工作半径 Work radius	800mm-3150mm

DJ-FX自动封箱机 Automatic carton sealer



纸箱上盖自动折入,平稳顺畅,封箱作业一气呵成,美观省力,可配合自动化包装机械系列使用。
Auto folding for top lid ensures smooth and suitable sealing motions. The entire sealing operation is automatically performed, providing elegant outlook and labor-saving, the machine can be operated together with automatic packaging line.

型 号 Model	DJ-FX
适用纸箱 Suit Carton	(L)200-600 (W)150-500 (H)150-500mm
台面高度 Table height	650-800mm
装箱速度 Filling speed	18-25carton/min
机械尺寸 Machine size	L×W×H 2300×650×1500mm
使用电源 Power supply	110V,220V single phase,50/60Hz
使用气源 Use air	5kg/cm³
胶带宽度 Type width	48mm,60mm, 72mm (alternative use)
机械重量 Machine weight	400kg

DJ-SG全自动上盖旋盖机 Automatic capping machine



旋盖机主要有理盖、落盖、输瓶、升降、输送带、剔除机构等几部分组成,通过人机界面控制输瓶,旋盖速度快,最快为300瓶/分,适应性强,对于不同形状的瓶盖都能旋紧,旋盖松紧一致性好等优点。其最大的优势在于每个传动部分由单独的电机控制,调整容易、耐用、可靠,其他同类产品采用同步带或链轮传动方式,容易损坏或旋盖不紧。

Capping machine is mainly justified cover. Drop cap.Bottle conveying. Elevating conveyor belt. Reject mechanism composed of several parts, through man-machine interface control bottle conveying,capping speed, the fastest to 300bottles / min, adaptable, for different shapes can tighten the cap, capping elastic consistency and good. Its biggest advantage is that each transmission part by a separate motor control, easy to adjust, durable, reliable, and other similar products using the timing belt or chain transmission, easily damaged or cap is not tight.

主机尺寸 Machine size	998x628x1438mm
上盖落盖机尺寸 Give cover machine size	1548x820x1780mm
适应旋盖速度 Speed	0-300 瓶 / 分
适用盖直径 Cover Diameter	直径 10-100mm
适用盖高度 Cover height	10-50mm
适用瓶直径 Bottle diameter	直径 10-120mm
适用高度 Bottle height	40-280mm
电源 Power supply	220V50HZ

简要说明及特点 Brief instruction

DJ-TB全自动贴标机 Automatic labeling machine

* 核心工作原理: 分瓶机构将产品分开后, 传感器检测到产品经过, 传回信号到贴标控制系统, 在适当位置控制系统控制相应电机送出标签并贴附在产品待贴标位置上, 产品流经覆标装置, 覆标带带动产品转动, 标签被滚覆, 一张标签的贴附动作完成;
* 操作过程: 放产品(可接流水线)→产品输送(设备自动实现)→产品分距(设备自动实现)→贴标(设备自动实现)→覆标(设备自动实现)→收集已贴标产品。

* Core works: Sub-bottle institutions after the separation of the product, the sensor detected after the return signal to the labeling control system, the control system in place to control the corresponding motor sends a label and attach to be in the product labeling position, product flows through the overlying standard device, follow standard belt driven product rotation, label roll cover, a label attached action is completed;
* Operation: put products (which can be accessed pipeline) -> product conveyor (the device automatically) -> points away from (the device automatically) -> Labeling (device automatically) -> follow standard (equipment automatically) -> collect labeling products.



型号 Model	DJ-TB	
贴标精度 Label accuracy	±1mm (不含产品、标签误差);	
贴标速度 Label speed	20~200件/分钟(与产品尺寸有关);	
适用产品尺寸 product size	C20≤产品直径≤C150mm;	
适用标签尺寸 label size	15≤宽度≤200mm, 长度≥20mm;	
整机尺寸 Machine size	2000×900×1500mm(长×宽×高);	
适用电源 Power supply	220V 50/60Hz;	
整机重量 Total weight	150Kg	
以上为标准机型技术参数, 其他特殊要求和功能, 可量身订做。We can design as your require.		

DJ-JT成品隧道金属检测器 Throat material Detector



型号 Model	DJ-JTI	DJ-JTII
称量范围 Weighing range	1-1000g	5-25kg
速度 Speed	45	5-30
精度 Precision	±1	±5
最小刻度 Minimum scale	0.1	1
产品预设模式 Product design model	10	10
机器尺寸 Machine size	1050×681×1260mm	
剔除装置 Removing device	吹气剔除法 / 拔杆剔除法 Blowing out / rod removal method	
电压 Voltage	220V	
功率 Power	300W	

DJ-JT100物料管道金属检测器 Finished metal detector



型号 Model	DJ-JT100I	DJ-JT100II
称量范围 Weighing range	1-1000g	5-25kg
速度 Speed	45	5-30
精度 Precision	±1	±5
最小刻度 Minimum scale	0.1	1
产品预设模式 Product design model	10	10
机器尺寸 Machine size	1050×681×1260mm	
剔除装置 Removing device	吹气剔除法 / 拔杆剔除法 Blowing out / rod removal method	
电压 Voltage	220V	
功率 Power	300W	

DJ-ZX重量选别称 Weight sorting scale



型号 Model	DJ-ZXI	DJ-ZXII
称量范围 Weighing range	1-1000g	5-25kg
速度 Speed	45	5-30
精度 Precision	±1	±5
最小刻度 Minimum scale	0.1	1
产品预设模式 Product design model	10	10
机器尺寸 Machine size	1050×681×1260mm	
剔除装置 Removing device	吹气剔除法 / 拔杆剔除法 Blowing out / rod removal method	
电压 Voltage	220V	
功率 Power	300W	

简要说明及特点 Brief instruction

铁听罐装生产线流程:

本系统设备适用于奶粉、蛋白粉及其它营养粉装到铁听罐, 并且需要抽真空充氮封罐, 为整线完整的流水线设备。

包装物料: 奶粉、蛋白粉、其它营养粉

适用重量: 100-1000克

适应罐规格: #300, #307, #401, #502罐, 适应罐高: 60-260mm

生产能力: 7-50罐/分钟, 速度主要取决于抽真空充氮封罐机台数, 若配6台封罐机, 速度则为42罐/分钟

单台封罐机速度: 6-7罐/分钟

充填精度: ±1-1.5克

残氧量: ≤3%

电源: 3相 380V 50Hz

整线功率: 48.33

压缩空气: 1.45m³/min, 压力: 6kg/cm²

氮气: 纯度>99.99%, 压力: 0.4Mpa; 3.5立方米/小时/台, 6台需求量为21立方米/小时

铁听罐装生产线: 自动卸罐、理罐、空罐吹扫杀菌、自动充填、罐自动分配、自动抽真空充氮封罐、罐身自动清理、自动喷码、自动翻罐、自动压罐盖、人工装箱等工作;

Automatic unscrambling, sterilizing, filling, evacuating, gasifying and seaming of cans.

Packing products: Milk powder, Albumen powder, and other Nutrition powder

Packing weight: 100-1000g

Can size: #300, #307, #401, #502, Height: 60-260mm

Capacity: 7-50 can per min, The speed refer to how many sets Vacuum Nitrogen Seaming Machine. If have 6 sets seamer, The speed is 42 cans per min.

Seamer capacity: 6-7 cans per min per set

Packing accuracy: ±1-1.5g

Remaining oxygen: ≤3%

Power supply: 3 Phase 380V 50Hz

Total power: 48.33kw

Air supply: 1.45m³/min, Pressure: 6kg/cm²

Nitrogen: Purity>99.99%, Pressure: 0.4Mpa; 3.5 cbm/hour/set, 6 sets need 21cbm/hour



工艺流程 Production Process

全自动摇摇瓶灌装线 Automatic Shake Bottle Filling Line

(摇摇杯) 全自动箱式理瓶机 → 空罐杀菌吹扫机 → 6斗颗粒称 → 双头转盘接料机 → 双头螺杆剂定量灌装机 → 单头液氮加注机 → 双头爪式压盖旋盖机 (非标打盖) → 自动套标机收缩 → 激光打码机 (紫外线) → 人工装箱

Bottle feeder → Empty can sterilization blower → Feeding filling machine → Double-head powder filling machine → Liquid nitrogen filling machine → Capping machine → Sleeve labeling machine → Laser coding machine → Bottle collect

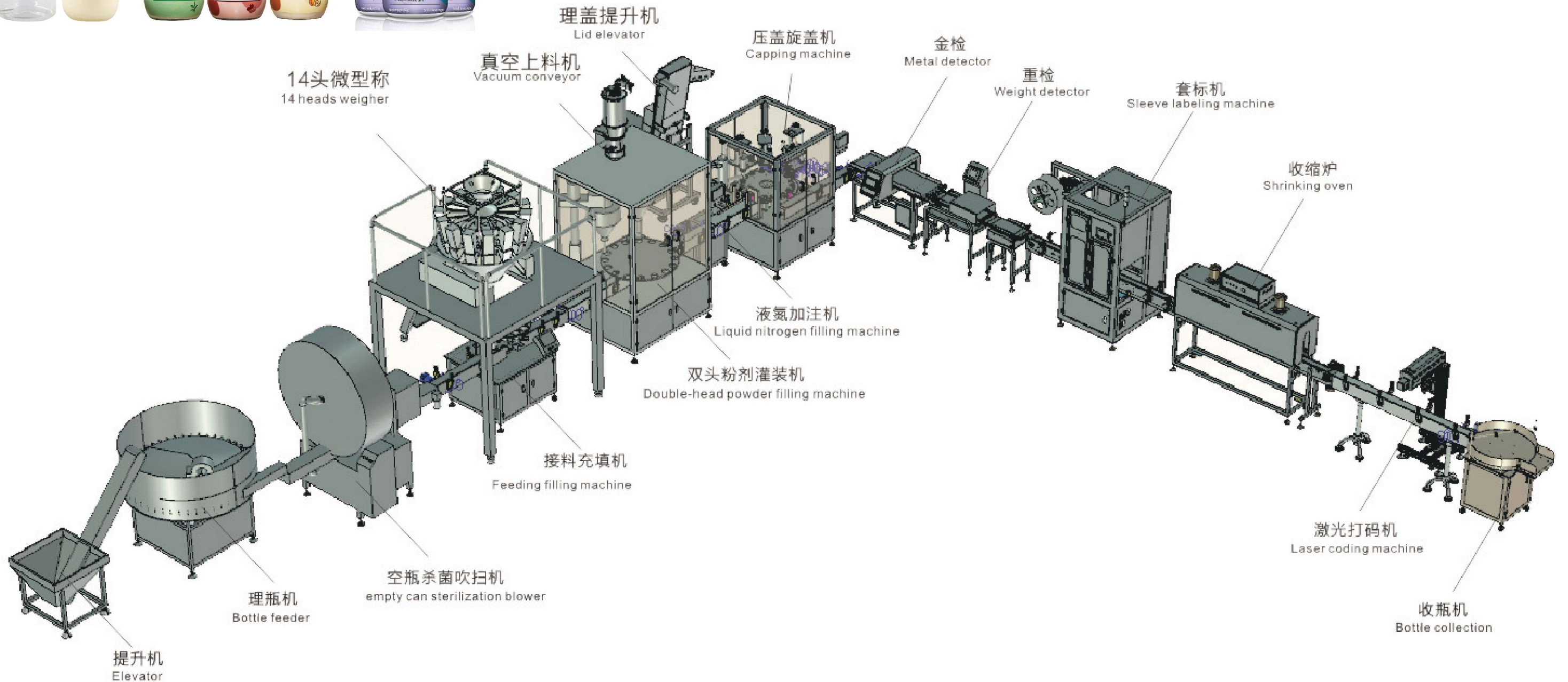

简要说明及特点 Brief instruction

- 产品规格/物料: 代餐粉灌装, 塑料瓶 (具体尺寸以实物为准)
- 整体生产能力: 50-55瓶/分钟 (速度跟物料、灌装量、瓶口大小有关)
- 计量精度: ±1.5克 (计量精度与物料有关)
- 压缩空气耗气量: 约0.4立方/分钟0.6-0.8Mpa (客户自备)
- 占地面积: 约长25米*宽3.5米*高3.7米
- 输送带离地高度: 900mm
- 用电总功率: 220V/380V 50/60Hz, 约50KW
- Packing Specification/Products: Bottle/ Meal replacement powder (specific size is subject to the actual product)
- Capacity: 50-55 bottles/min (speed is related to material, filling volume, bottle diameter)
- Packing Accuracy: ±1.5g (measurement accuracy is related to material)
- Compressed Air Consumption: 0.4m³/min 0.6-0.8Mpa
- Machine Land Area: about 23m*3.5*3.7m
- The height of the conveyor belt from the ground: 900mm
- Total Power: 50kW

工艺流程 Production Process

上料提升机→立式包装机→金检机→选别称→开箱机→装箱机→称重剔除机→封箱机→打包机→定位抓取线→供栈机→机器人码垛机→栈板输送机
Feeding machine→Vertical packaging machine→Metal detector machine→Weight sorting scale→Automatic carton opener→Automatic carton filling machine→Weighing and rejecting machine→Carton sealer→Strapping machine→Positioning and grabbing line→Feeding stacker→Robot palletizer→Pallet conveyor

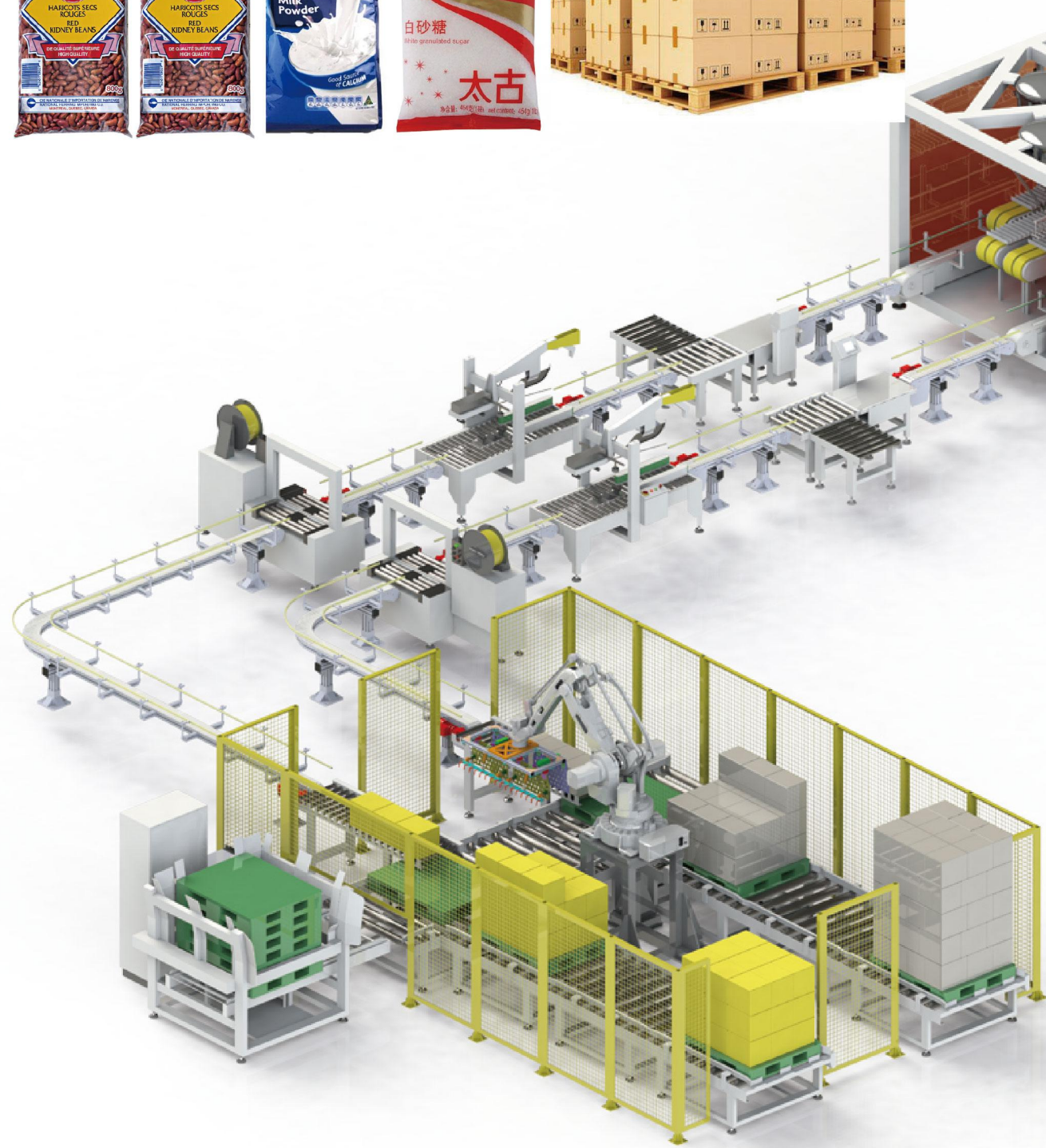

简要说明及特点 Brief instruction

- 本生产线专门与立式包装机对接，满足后端包装全自动化生产需求。
- 产能：每分钟100-300包（可根据实际需求产量定制）。
- 生产线适用产品：
- 配多头组合秤适合：饼干、糖果、薯片、膨化食品、花生、坚果、红枣、葡萄干、牛肉粒、茶叶、干货、种子、塑料粒子等颗粒物料。
- 配螺旋充填头适合：奶粉、豆奶粉、芝麻糊、咖啡粉、麦片、面粉、调味品、洗衣粉等粉剂物料
- 配置杯下料头适合：白糖、盐、味精、调味品等细小颗粒物料。

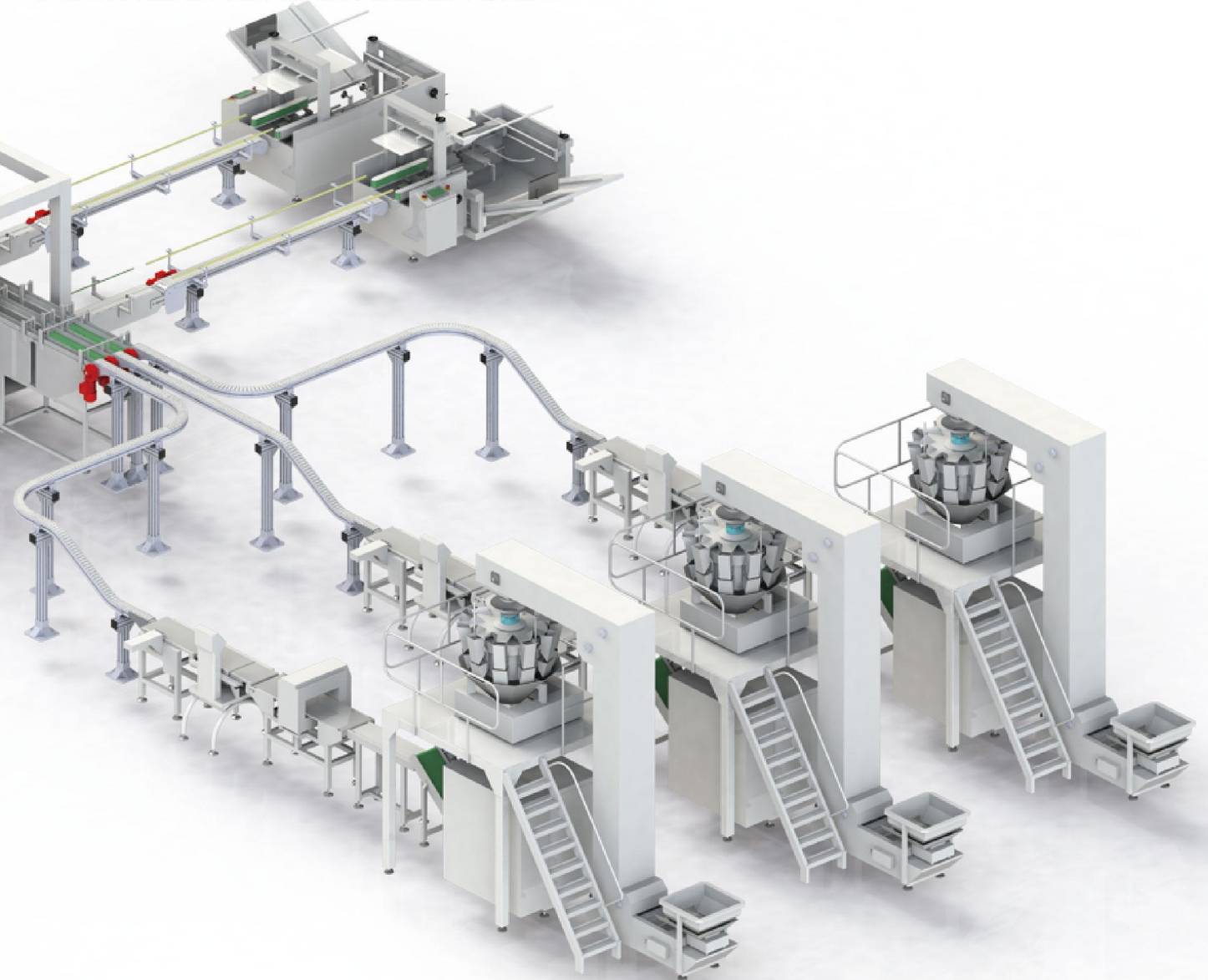

- This production line is specially connected with the vertical packaging machine to meet the needs of fully automated production of back-end packaging.
- Capacity: 100-300 bags/min (can be customized according to the actual needs).
- Applicable products of the production line:
- Equipped with Multi-head weigher suit for: biscuits, candies, potato chips, puffed food, peanuts, nuts, dates, raisins, beef cubes, tea, dry goods, seeds, plastic particles and other granular materials.
- Equipped with Auger filler suit for: powdered materials such as milk powder, soy milk powder, sesame paste, coffee powder, oatmeal, flour, condiments, food additives, washing powder, chemical raw materials, etc.
- Equipped with dosing cup suit for: sugar, salt, monosodium glutamate, condiments and other fine particles.

简要说明及特点 Brief instruction

上料提升机→给袋式包装机→金检机→称重选别称→开箱机→装箱机→称重剔除机→封箱机→打包机→供栈机→码垛机→栈板输送机
Feeding machine→Premade bag packaging machine→Metal detector machine→Weight sorting scale→Automatic carton opener→Automatic carton filling machine→Weighing and rejecting machine→Carton sealer→Strapping machine→Positioning and grabbing line→Palletizing machine→Pallet conveyor



简要说明及特点 Brief instruction

- 本生产线专门与给袋式包装机对接，满足后端包装全自动化生产需求。
- 产能：每分钟60-200包（可根据实际需求产量定制）。
- 生产线适用产品：
- 配多头组合秤适合：饼干、糖果、薯片、膨化食品、花生、坚果、红枣、葡萄干、牛肉粒、茶叶、干货、种子、塑料粒子等颗粒物料。
- 配螺旋充填头适合：奶粉、豆奶粉、芝麻糊、咖啡粉、麦片、面粉、调味品、食品添加剂、洗衣粉、化工原料等粉剂物料。
- 配量杯下料头适合：白糖、盐、味精、调味品等细小颗粒物料。
- 配液体充填头适合：洗手液、洗衣液、洗洁精等液体物料。

- This production line is specially connected with the premade bag packaging machine to meet the needs of fully automated production of back-end packaging;
- Capacity: 60-200 bags/min(can be customized according to the actual needs);
- Applicable products of the production line:
- Equipped with Multi-head weigher suit for: biscuits, candies, potato chips, puffed food, peanuts, nuts, dates, raisins, beef cubes, tea, dry goods, seeds, plastic particles and other granular materials;
- Equipped with Auger filling suit for: powdered materials such as milk powder, soy milk powder, sesame paste, coffee powder, oatmeal, flour, condiments, food additives, washing powder, chemical raw materials, etc.
- Equipped with dosing cup suit for: sugar, salt, monosodium glutamate, condiments and other fine particles.
- Equipped with liquid filling head suit for: liquid materials such as hand sanitizer, laundry detergent, and detergent.

