



Reminder

1. Please read this installation and maintenance manual before installation! Save these instructions for future reference!
2. Installation: round pole

Warranty

1. The warranty period of this product is 5 years. If the product has quality problems during the warranty period, please contact us or our authorized dealer. We will repair or replace new products for you for free!
2. If the product is man-made damage or irresistible external environment damage such as natural disasters is not covered by the product warranty! If you need product repair or replacement service, please contact us or our authorized dealer, and we will charge the appropriate fee for the repaired or replaced product!
3. Products and services are subject to change without notice!

Application

Site, area, road and other lighting applications; ideal for large retailers, commercial to medical properties, and big box retailers. And suitable for roadways.

Specification

Model No.	SL050Y	SL100Y	SL150Y	SL200Y
Power	30W	100W	150W	200W
Net Weight	3.0 kg	4.0 kg	4.7 kg	5.6 kg
Power Factor	PF>0.90			
Spigot Size	Ø60mm			
Input Voltage	100 to 277 VAC; 50Hz/60Hz			
Working Temperature	-30°C to +50°C			
Working Humidity	15% to 90% RH			
IP Rating	IP65			
Warranty	5 years			

Dimension (unit:mm)

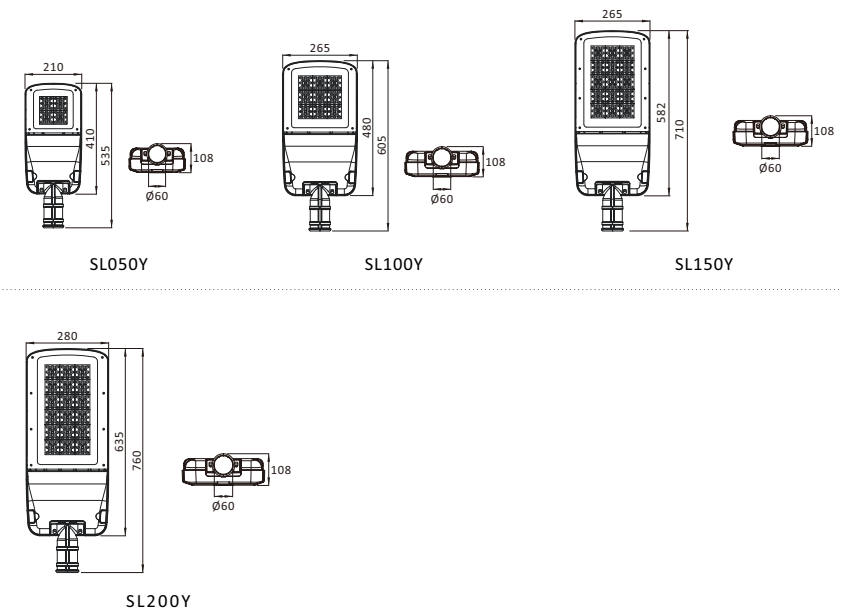

Wiring Diagram

Regular:

AC/N	blue	AC/N	white
AC/L	brown	AC/L	black
⊕FG	green/yellow	⊕FG	green

Dimmable:

DIM+	purple	DIM+	purple
DIM-	pink	DIM-	gray

Warning

1. All installations of the lamps must comply with the national electrical codes and be carried out in compliance with local laws and regulations.
2. Before installing lamps and maintenance, you must cut off the power supply! During the installation of the lamp, it must be installed and operated by qualified personnel with relevant certificates! The object where the lamp is installed must be able to bear no less than 3 times the weight of the lamp!
3. Never modify the circuit and structure of the lamp, the lamp must be effectively grounded during installation!
4. Due to the high intensity of light generated when the lamp is turned on, do not direct the eyes when the lamp is turned on during close operation and maintenance!
5. The installer is responsible for verifying and recommending the installation structure of the luminaire, including poles, cross arms, walkway brackets and other installation structures, to ensure that the weight of the luminaire is supported, to bear the wind load, and to meet all other applicable codes and regulations.
6. Do not hang any objects with wires or control wires! The wires or control wires on the lamps cannot bear the weight.
7. Store the lamp in a clean and dry place, avoiding dust, moisture and direct sunlight.
8. When cleaning the lamp, please use a dry cotton cloth to wipe the optical lens or luminous surface of the lamp, and brush the other parts. Do not use any abrasives, such as car wax, brass cleaner or other polishing agents or chemicals!

Light Arm Details

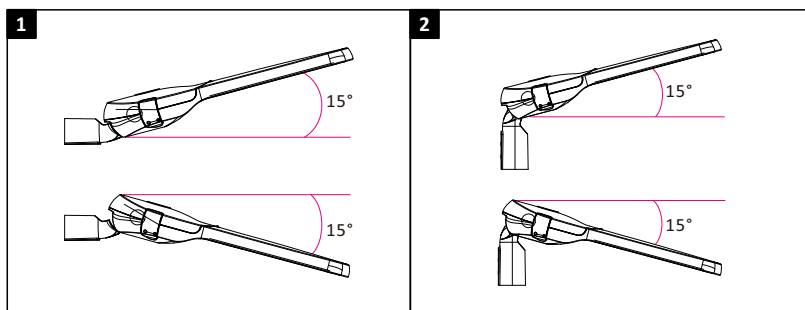

Install Steps

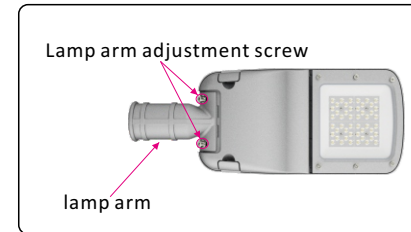

- 1 Adjust the installation direction of the light arm according to the type of light pole and lighting needs. For the adjustment of the light arm, please refer to the installation instructions of the light arm on the left.

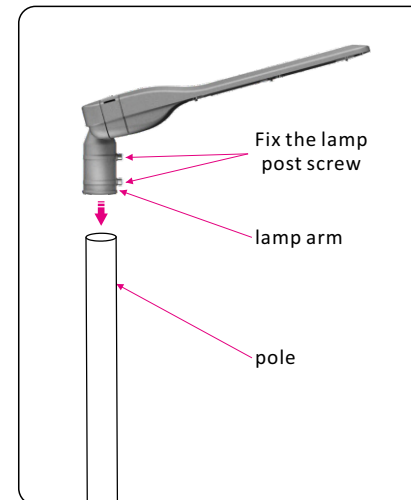

- 2 Connect the wires according to the wiring diagram on the left, then install the street lamp on the lamp post, and lock the two screws on the lamp arm that fix the lamp post!



- 3 Turn on the light and turn on the lamp, and adjust the two screws to fix the lamp arm according to the lighting needs. The adjustment is completed and the installation is successful!