



YELLOWRIVER
MAKE YOUR STAGE TO BE MORE EXCELLENT

10W*27 PCS RGBW 4 IN 1 PAR LIGHT
(Model: YR-P27QA)



User Manual

Please read these instructions carefully before use

Attention:

The ideal working environment of this equipment is between 0 and 35 degrees, and the surface temperature of the lamp body is between 40 and 70 degrees. For safety, it is absolutely necessary for the user to follow the safety instructions and warnings given in this manual.

Technical parameters:**Light source parameters:**

Light source: 27x10W(4-in-1 RGBW, high temperature lens package)

Light source life: 50,000 hours

Antistatic: up to 2000V HBM

Light source heat conduction: bonding + high efficiency heat conduction chassis

Light source protective mirror: bullet protective mirror

Light emitting lens: high temperature resistant PC+PMMA

Light Angle: 25 degrees

Control parameters:

Stroboscopic: 0-20Hz, standard stroboscopic

Dimming: Standard linear dimming

Control signal: DMX512(Digital MultipleX 512)+RDM, in line with the international standard light control transmission protocol

Control channels: 8 channels A / 8 channels B

Built-in effects: Stroboscopic + static color mixing + self-walking

Operation mode: console, manual, master-slave, voice control, optional WIFI+ mobile APP control

Cooling method: fin + fan for heat dissipation

Working parameters:

Operating voltage: AC100V-240V (50/60HZ)

Total rated power: 200W

Power factor: 0.56

Ambient temperature: <40 degrees

Light parameters:

Case material: Engineering aluminum alloy (high temperature resistance),
fine sand paint (high-end wear resistance)

Display: LED bright red digital tube +4 mechanical buttons

Power interface: with one input and one out powercon socket

Signal interface: with an in and out XLR connector

IP rate: IP20

Net weight: 2.8KG

1. SIZE

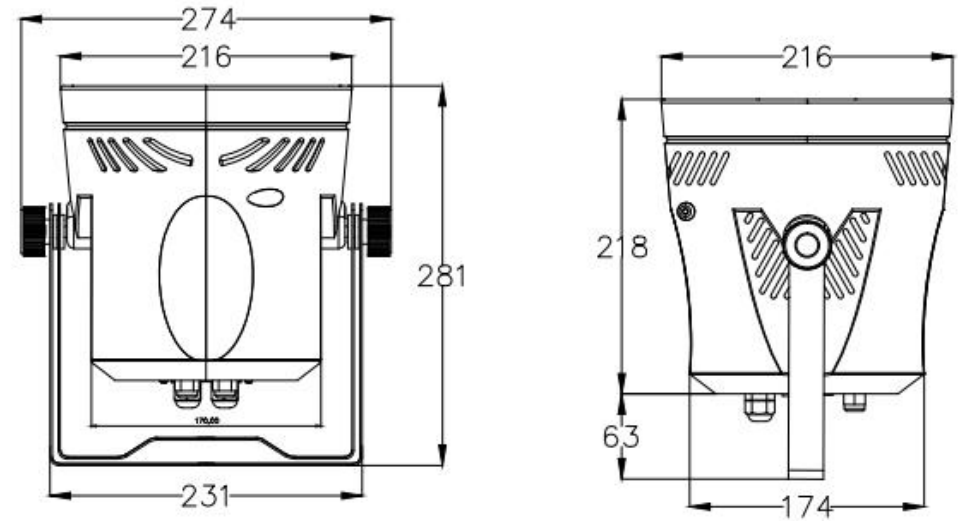

2. Operation instruction

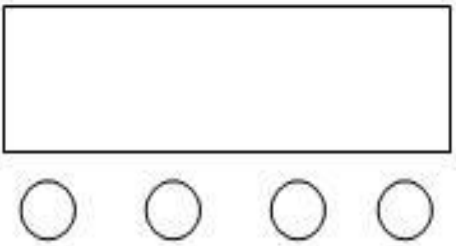

MENU UP DOWN ENTER

Pressing the MENU key will loop through 12 different menus. Press ENTER to enter the corresponding menu. Press UP or DOWN to change the current value. Press ENTER to save the current value.

3. MENU FUNCTION

S/N	MENU	FUNCTION
1	A001	8 channel A address code Settings: 001-512, blinks when no signal
2	d001	8 Channel B address code Settings: 001-512, blinks when no signal
3	FF00	Gradient FF00-FF99
4	EE00	Pulse changes EE00-EE99
5	CC00	Jump CC00-CC99
6	S0UD	Voice-activated mode
7	R255	Red brightness adjustment: 0-255
8	G255	Green Brightness adjustment: 0-255
9	B255	Blue brightness adjustment: 0-255
10	W255	White brightness adjustment: 0-255
11	S-32	Reserved functions to be expanded
12	ld01	Reserved functions to be expanded
13	SW-0	Reserved functions to be expanded



合格证

Certification

产品名称: _____
Item Name

产品型号: _____
Item NO.

检验员: _____
Inspector

检验日期: _____
Inspection Date

执行标准: GB7000 · 217-2008
Implementation Standards

本产品经检验合格，准予出厂！

This product passed the inspection

广东雅格莱灯光音响有限公司
Guangdong YaGe Lai Lighting & Audio Limited
全国电话: 400-618-4388
Tel: 400-618-4388

保修卡

Protection to Fix Card

非常感谢您使用我们的产品

1. 本产品从购买日起，正常使用并未经拆修，经保修人员确认属产品大质量问题，一年内享受保修服务(其中光源为易耗品只享受三个月保修)，在作保正将情况下均提供维修。

2. 保修卡应在购买时予填写，保修卡无本公司保修章无效，产品维护时请带保修卡。

Very thank you for using our products

1. From the date of purchase, if the product is operated correctly without disassembling and fixing, at the same time, the quality problem was confirmed by our after-sale service department, we will offer maintenance service at any time under any normal situation within one year.

2. The warranty card should be filled in at the time of purchase. The warranty card is invalid without our company's warranty seal. Please bring the warranty card when maintaining the product.

顾客姓名 Customer Name	购买日期 Purchasing Date	产品型号 Product Model	购买商 Purchaser

保修记录:
Warranty record

广东雅格莱灯光音响有限公司
Guangdong YaGe Lai Lighting & Audio Limited
地址: 肇庆市高新区大道41号肇庆万洋众创城G10
Address: G10, Wanyangchuangcheng, No. 41, Dawang Avenue, Daxing District, Zhaoqing City, Guangdong Province

4.DMX 512 CHANNEL

8CH A

S/N	MENU	FUNCTION
CH1	Total dimmer	0-255: Total dimming linear dimming, from darkest to brightest.
CH2	stroboscopic	0-9: None, 10-255: slow to fast.
CH3	Function model	0-29: invalid; 30-39: red; 40-49: green; 50-59: blue; 60-99: Red - green; 70-79: Red - blue; 80-89: green-blue; 90-99: white; 100-149: Gradual change; 150-199: pulse change; 200-229: jump; 230-255: Voice control;
CH4	Function speed	0-255: Slow to fast
CH5	red	0-255: Red linear dimming, from darkest to brightest.
CH6	green	0-255: Green linear dimming, from darkest to brightest.
CH7	blue	0-255: Blue linear dimming, from darkest to brightest.
CH8	white	0-255: White linear dimming, from darkest to brightest.

8CH B

S/N	MENU	FUNCTION
CH1	Total dimmer	0-255: Total dimming linear dimming, from darkest to brightest.
CH2	red	0-255: Red linear dimming, from darkest to brightest.
CH3	green	0-255: Green linear dimming, from darkest to brightest.
CH4	blue	0-255: Blue linear dimming, from darkest to brightest.

CH5	white	0-255: White linear dimming, from darkest to brightest.
CH6	stroboscopic	0-9: None, 10-255: slow to fast.
CH7	Function model	0-29: Dimming; 30-39: red; 40-49: green; 50-59: blue; 60-69: red - green; 70-79: Red - blue; 80-89: green-blue; 90-99: white; 100-149: Gradual change; 150-199: pulse change; 200-229: jump; 230-255: Voice control;
CH8	Function speed	0-255: Slow to fast

5.Master-slave mode online description

Master/Slave connection: Set one machine as the host, select the operating mode of the menu, set the other machine as the slave machine, and set the slave machine to the DMX address code state. When the signal cable is connected, the slave is controlled by the host and its functions are synchronized with the current functions of the host.

Console control of multiple products: set all products to the same or different address code value (note: before control, the controlled products must be set to DMX menu to synchronize control, address code value is set to 001), connect the signal line, at this time, slave console control, function and the current function of the console synchronization.

6.Instructions and remarks



Warning. Electric shock

The light source inside this lamp should be replaced by our company or our service agent or person with similar qualification

1. Check whether the power supply and voltage are normal before use. If the voltage fluctuates greatly, it is recommended to use voltage stabilizer or voltage regulator.

2. The equipment is IP20 grade, it is strictly forbidden to use the smoke screen of the dry ice machine to cover the lamps.

3. The equipment belongs to the first-level protective light. The power cord of the product must be grounded and well grounded when used. The yellow and green double color lines must be grounded and taken care of by professionals.

4. Do not touch its surface when operating

5. The internal components of the equipment must be purchased from the manufacturer.

6. Product power cord must be grounded and well grounded

7. When using console, try to avoid neighboring interference sources. (Example: wireless walkie-talkie, high-frequency emission source, etc.)

8. When using device, only 20 sets of the same product can be controlled within 20 meters of the same signal line. If it exceeds this range, a signal amplification device must be used to amplify the signal before it can be used, and the DMX output port on the last light Install a terminal product and solder a 120 ohm 1/4W resistor between Pin2 and Pin3.

9. This product can not exceed 4 lamp connections when using hand-in-hand connections. The company is not responsible for burning out the lamps and other accidents.

10. If the display screen, lens produces visible damage, that is, damage to the degree of failure, such as cracks or deep marks, should be replaced;

7. Installation requirement

1. The product shall be free from corrosive vapors and gases in the

operating environment and shall not contain inflammable and explosive articles within 3 meters.

2. Keep the distance between the light outlet direction and the subject at least more than 0.5 meters.

3. The direction of the light is an optical lens. No external force can hit the glass in the process of operation. If the lens is damaged, it can only be used after the professional technician replacing the lens of the same specifications.

4. When the outer cover of the power cord is damaged, it must be replaced with a new power cord of the same specification by relevant professional personnel before use.

5. When the product is hung and installed, the load bearing of the hanging device shall be at least 3 times greater than the weight of the product, and the safety rope shall be fastened on the auxiliary hanging device of the light, and the load bearing of the safety rope shall be more than 3 times greater than the weight of the product.

6. The products must be controlled within the use time indicated by the light source, and after the use time is reached, please replace the light source and use it again in time, otherwise the light source is easy to deform or weaken, affecting the use.

**The company reserves the right to amend this product manual
without prior notice**