

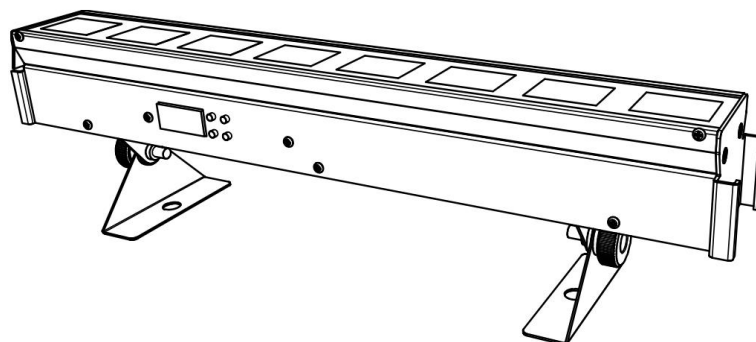

**YELLOWRIVER**  
MAKE YOUR STAGE TO BE MORE EXCELLENT

## LED SLIM BAR



**YR-L0309UV(UV Color)**

### **User Manual**

*Please read these instructions carefully before use*

## **Contents**

### **Section 1. Getting Started**

- ✧ Unpacking
- ✧ Safety Instruction

### **Section 2. Set Up**

- ✧ Installation
- ✧ Controlling Board
- ✧ Machine Connection

### **Section 3. troubleshooting**

- ✧ Troubleshooting

### **Section 4. Reference**

- ✧ Control Menu
- ✧ DMX Protocol
- ✧ Dimmer Curve
- ✧ Specification

### **Section 1. Getting Started**

- ✧ Unpacking
- ✧ Safety Instruction

## **Unpacking**

1pc Fixture

1pc User Manual

Thanks for choosing our LED slim bar. Carefully unpack the box and check the contents to ensure that all parts are present and in good conditions. If anything damaged in transit, notify the shipper immediately and keep the packing material for inspection. Again, please save the carton and all packing materials. If a fixture must be returned to manufacturer, it is important that the fixture be returned in the original manufacturer box and packing.

## Safety Instruction

For your safe, please read this user manual carefully before turn on the fixture. This machine should be operated by qualified engineer!



- Please conserve this manual as operation guidance. If you sell this product to other user, please make sure that they also receive this user manual.
- Always make sure that you are connecting to the proper voltage and that the line voltage you are connecting to is not higher than that stated on the decal or rear panel of the fixture.
- If the fixture is intended to indoor use only. To prevent risk of fire or shock, do not expose fixture to rain or moisture. Make sure there are no flammable, explosive or corrosive materials surrounded in 10meters while operating.
- The unit must be installed in a location with adequate ventilation, at least 5m away from adjacent surfaces. Be sure that no ventilation slots are blocked.
- Some fixture may carry high heat, do not aim at objective more than 2minutes.
- Safe rope should be used to install machine. Bearing of safe rope should be more than 3times of the machine weight. Complimentary signal cable transmits signals to 20 unit fixtures at most. Signal amplifier is a must to connect more fixtures. And a terminal should be added at the end of last fixtures' DMX sockets, 120 Ohm, 1/4W resistance need welding between Pin 2 and Pin3.
- Always disconnect from the power source before servicing or replacing fuse/lamp and be sure to replace with same fuse/lamp size and type. Cut off power before moving, repairing and cleaning the machine.
- To avoid electric shock, all fixtures must be connected to circuits with a suitable earth connection.
- Always secure fixture using a safety chain and carrying handles.
- Do not operate at ambient temperatures higher than 104°F (40°C).
- The power cable for this fixture is 1 m m<sup>2</sup>, please mind the safety requirements in actual using, if any wrong operation, our company takes no responsibility for any loss. Also, make sure the power cord is never crimped or damaged.
- In case of failure or mis-function occurred, stop using immediately. Never try to repair the fixture by yourself. Repairs carried out by unskilled people can lead to damage or malfunction. Please contact the nearest authorized technical assistance center. Buy the same spare parts/components from manufacturer directly.
- Avoid direct eye exposure to the light source while it is on.
- Do not power on and power off the fixture frequently
- When use DMX controller, please make sure that there is no interference sources(e.g. intercom, high frequency radio waves and radiation source)

**Caution!** There are no user serviceable parts inside the unit. Do not open the housing or attempt any repairs yourself. In the unlikely event your unit may require service, please contact your local distribution or after-sale service center.

## Section 2. Set Up

- ✧ Installation
- ✧ Controlling Board
- ✧ Machine connection

### Installation

- This machine should be mounted through the screw holes of truss. Safety rope is a must to fix fixture well. Make sure truss and safety rope have strong load capacity to bear more than 3 times of machine weight.
- This machine should be installed by qualified technician.

### Controlling Board

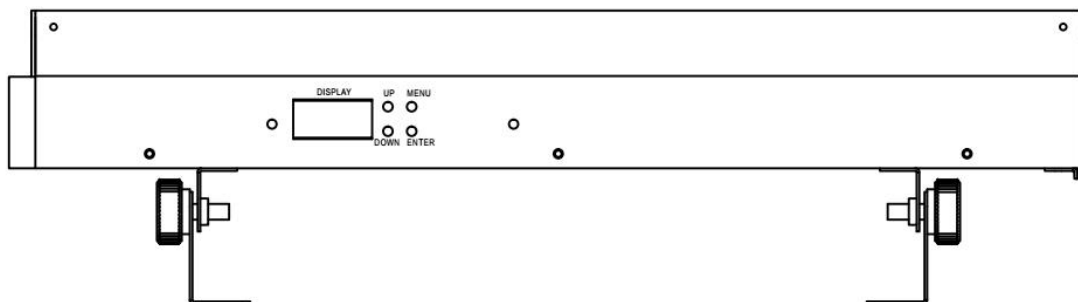

### Front display panel

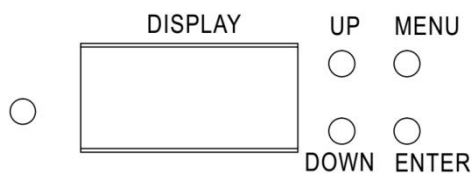

### Back panel

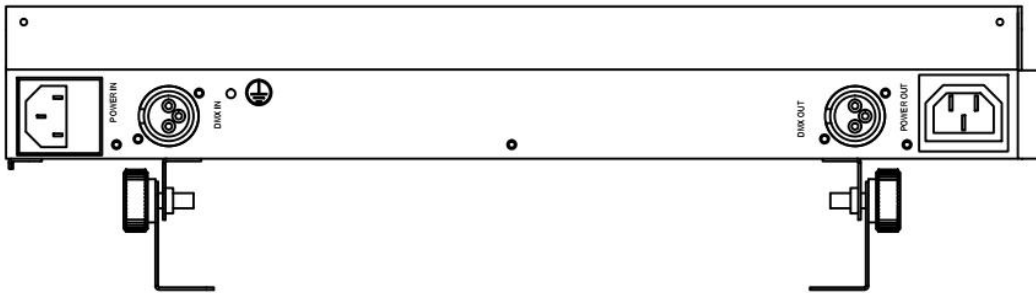

1. LED Display Panel
2. Button

Menu	Switch menu function
UP	Scroll upwards
DOWN	Scroll downwards
ENTER	Confirm by pressing ENTER

3. DMX Signal Input  
3 PIN XRL port for DMX512 signal input ( daisy chain);
4. DMX signal output  
3 PINXRL Port for DMX512 signal output ( daisy chain);
5. Power Input  
AC power cable port input/output

### Cable Connectors

Cables must have a male XLR connector on one end and a female XLR connector on the other end.

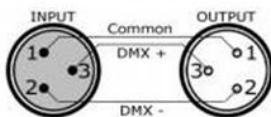

A word on termination: DMX is a resilient communication protocol, however errors still occasionally occur. Termination reduces signal errors, and therefore best practices include use of a terminator in all circumstances. If you are experiencing problems with erratic fixture behavior, especially over long signal cable runs, a terminator may help improve performance.



To build your own DMX Terminator: Obtain a 120-ohm, 1/4-watt resistor, and wire it between pins 2&3 of the last fixture. They are also readily available from specialty retailers.

Master and slave: select one machine as master, press the menu to choose the function you want. Press other machines' address to be DMX state. Use signal cable to connect machines one by one. Then slave machines will run the same as master machine.

Use controller to control lot of machines: if all machines are set the same menu data, or different manual data, after use signal cable to connect to controller, all machines will be controlled by controller. (before connect to controller, all machines should be in the same channel mode 3ch or 1ch).

### Section 3. Troubleshooting

Problem	Probable Cause(s)	Remedy
No response from fixture when power is applies	No power to fixture	Check power cables
	Primary fuse blown	Replace fuse
	Secondary fuse blown	Replace fuse
Fixture resets but does not respond correctly to controller(DMX mode operation)	Controller not connected	Connect controller
	Incorrect addressing of the fixtures	Check address setting on fixture and controller
	Bad data link connection	Inspect cables and correct poor connections and/or broken cables.
	Conflict between tracking and vector control	Eliminate scene cross-fade on controller
	Data link not terminated	Insert termination plug in output of last fixture

	Defective fixture or 2 devices transmitting on link	Bypass fixtures one at a time until normal operation is regained: unplug both connectors and connect them directly together
Colors cannot be mixed	Random color mixing is on	Turn off random color mixing
Fixture does not reset correctly	Electronic or mechanical failure	Contact service technician
No light, lamp cuts out intermittently, or burns out too quickly	Lamp missing or blown	Disconnect fixture and replace lamp
	Fixture or lamp is too hot	Allow fixture to cool. If problem persists, contact service technician

#### Section 4. Reference

- ✧ Control Menu
- ✧ DMX Protocol
- ✧ Dimmer Curve
- ✧ Specification

#### Control Menu

No.	Menu	Function
1	d3 --	DMX 3 channel control(need connecting controller)

2	d, 1--	DMX1 channel control(need connecting controller)
3	n---	r000 to r255: linear dimmer from dark to bright
4	F---	g000 to g255: strobe speed, from slow to fast
5	dr---	dr-0: Standard Dimmer Curve; dr-1: Dimmer Curve1; dr-2: Dimmer Curve2; dr-3: Dimmer Curve3; dr-4: Dimmer Curve4;

## DMX protocol

DMX512 Channel Chart: (3CH)

CH	Function	Specification
CH1	Dimmer	0-255 Linear Dimmer, from dark to bright
CH2	Strobe	0-5: N/A; 6-55: Random Strobe; 56-105: Pulse Strobe 106-155: Average Strobe; 156-205: Thunder Strobe 206-255: Standard Strobe
CH3	Dimmer Curve	0-20: Standard Curve; 21-40 Dimmer Curve 1; 41-60: Dimmer Curve 2; 61-80: Dimmer Curve 3; 81-100: Dimmer Curve4; 101-255:N/A

DMX512 Channel Chart: (1CH)

CH1	Dimmer	0-255 Linear Dimmer, from dark to bright
-----	--------	--

## Dimmer Curves:

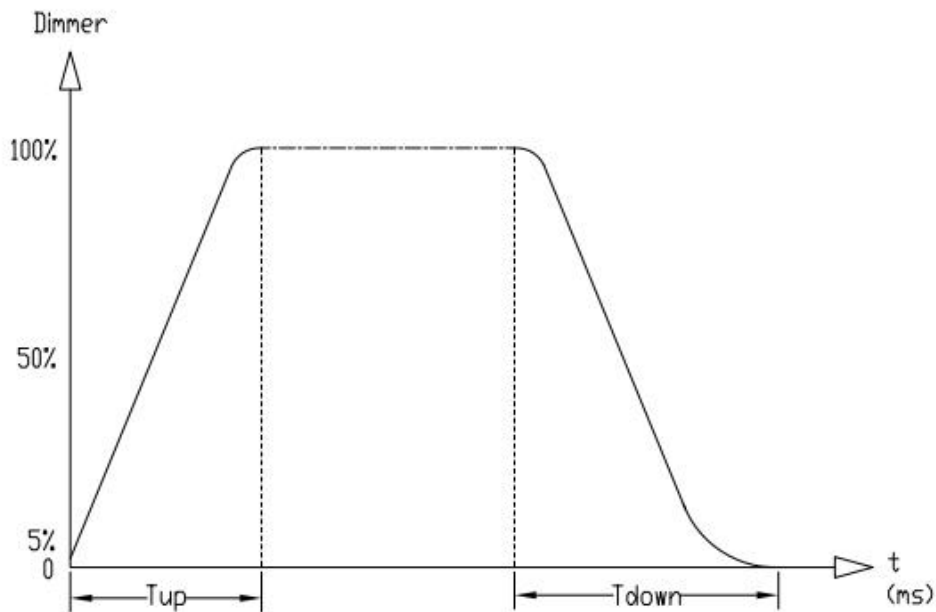

Ramp Effect	Menu	Tup(ms)	Tdown(ms)
-------------	------	---------	-----------

Standard Dimmer Curve	dr-0	0	0
Dimmer Curve1	dr-1	980	1010
Dimmer Curve2	dr-2	1210	1320
Dimmer Curve3	dr-3	1600	1710
Dimmer Curve4	dr-4	1850	1980

### **Specification**

Voltage: AC110V-240V

Frequency: 50/60Hz

Machine Power: 25W

Led source: : 9pcsx3W(uv color)

Beam Angle:110° (with reflector cup)

Strobe: 0~20Hz

Dimmer :1 standard +4 kinds of dimmer methods

Channel: 3/1CH (switchable)

Control Mode: DMX512/Manual/Master-Slave/Sound active

Cooling way: no fan, naturally cooling

Noise: silent

Display: LED Display

DMX: 3-pin XLR

IP: IP20

Net weight:0.75kg

Size:41.5\*5.7\*11.7CM



# 合格证

CERTIFICATE

本产品经检验符合技术条件, 准予出厂:  
The product Has Been Tested According To Technical Requirements And Passed:

检验员 \_\_\_\_\_

本公司有权对此份产品说明书进行修改, 恕不另行通知。

Our company reserve right to revise this user manual without notice!

**Innovation | Efficiency | Dedication | Harmonious**