

LED Flex series

User Manual

Ver. 1.0.1

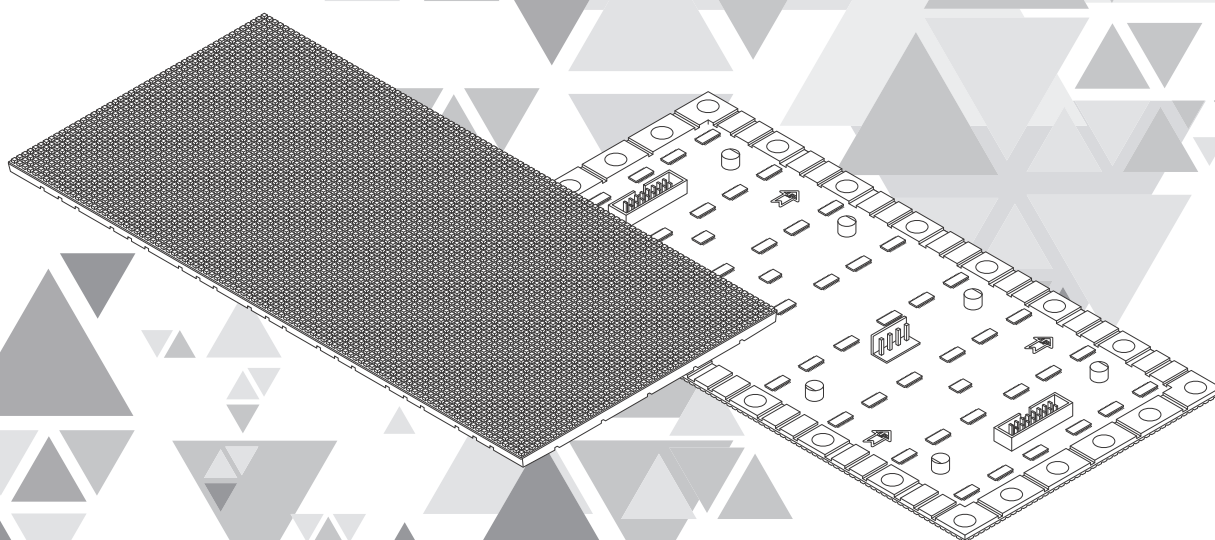

Safety and Caution

1. Precaution	1
2. Usage Precautions	1

Product Functions

1. Product Overview	2
2. List of Materials Used	2
3. Dimensions	3
4. Specifications	4

How to Use

1. Cabinet	5
2. Switching power supply	6
3. Module power cable	7
4. Receiving card	7
5. HUB75E cable	8
6. RJ45 cable	8
7. Module	9

Safety and Caution

1. Precautions

Read manual carefully before use.

Specifications may change without notice.

	Warning	Indicates risk of death or serious injury if misused.
	Caution	Indicates risk of injury or property damage if misused.

2. Usage Precautions

	Warning	<ul style="list-style-type: none"> • Check for missing parts or defects before use. • Do not repair, disassemble, or modify; may cause shock, fire, or damage. • After installation, regularly check for loose mounting parts. Risk of unit falling. • Fully insert plug; prevents shock or failure. • Do not pull, bend, or twist cables; fire or shock risk. • Cover unused connectors and USB ports with waterproof caps. Avoid long use in dusty or humid places; clean dust regularly. Risk of electric shock or fire. • Avoid flammable areas; fire risk. • Do not use or store in vibration, shock, dust, or corrosive/flammable gas environments. May cause overheating or fire. • Do not use in extreme temperature or high humidity environments. Risk of leakage or malfunction. • Do not spray water on the bottom of the unit. Risk of fire, electric shock, or failure. • Do not plug/unplug with wet hands; risk of shock/fire. • If smoke or abnormality occurs, turn off power immediately and contact seller. • Use only specified voltage outlet; fire or failure risk.
--	---------	---

	Caution	<ul style="list-style-type: none"> • Avoid unstable or noisy power supply. May damage components or cause no display. • Do not stare at the display surface for long periods. • Do not scrub panel surface with hard brushes. May cause deformation, discoloration, or failure. • As this product is a precision instrument, please take care not to apply excessive force, drop it, or subject it to impact. • Avoid use/storage in high heat, humidity, or direct sunlight. • Do not insert hands or objects into fan cover.
--	---------	--

Product Functions

1. Product Overview

The Flex series is an expandable LED module. Modules support curved surfaces and can be freely expanded by connecting vertically and horizontally.

2. Component List

[Standard Products]

● Module (LED Display)

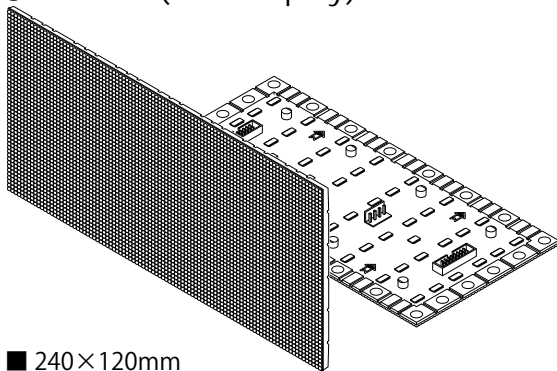

- 240×120mm
- 320×160mm

● Receiving Card

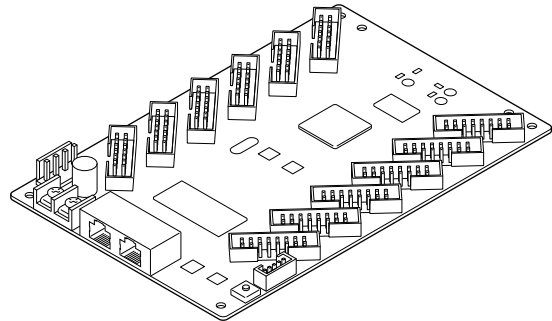

● Controller (MCU)

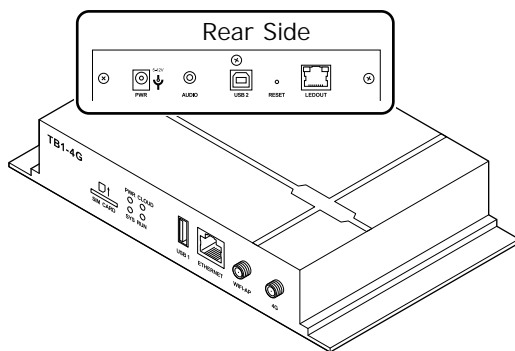

● Switching Power Supply

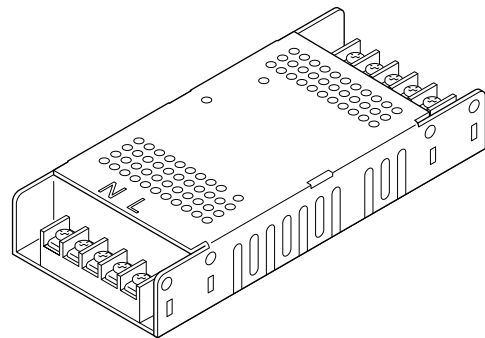

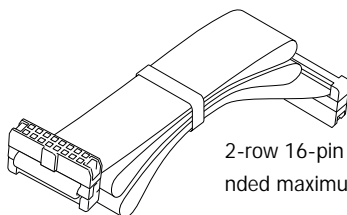

● HUB75E Cable

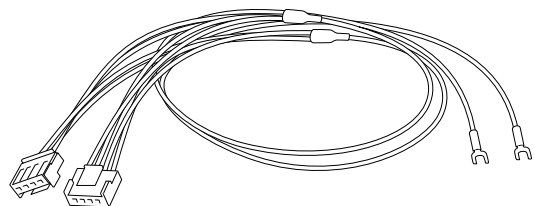

2-row 16-pin MIL connector. Recommended maximum length is 1000mm.

● Power Cable for Modules



 HUB75E cables may be mixed (locked/unlocked), but there are no functional issues.

3. Size

● Module

(Unit: mm)

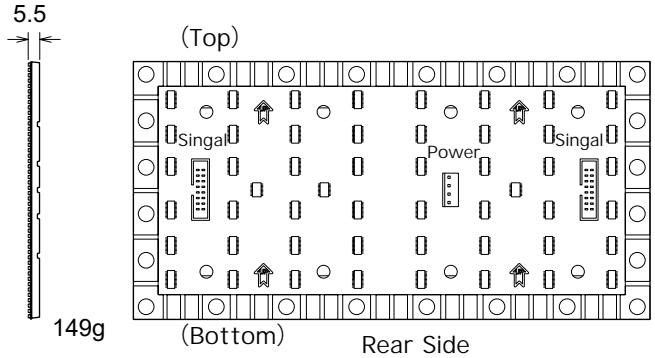
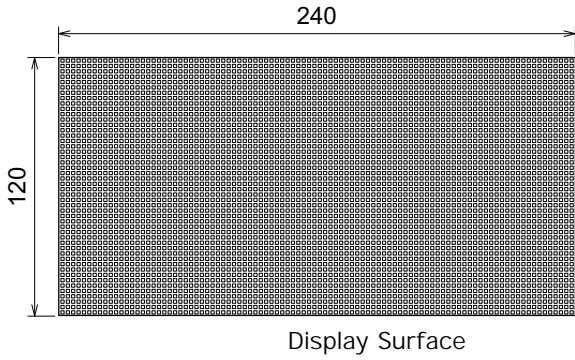

- 240×120mm ■ Max P.C : 17.28W
- 320×160mm ■ Avg. P.C : 7.2W

※ Ensure the "UP" arrow on the rear side points upward.

● Receiving Card

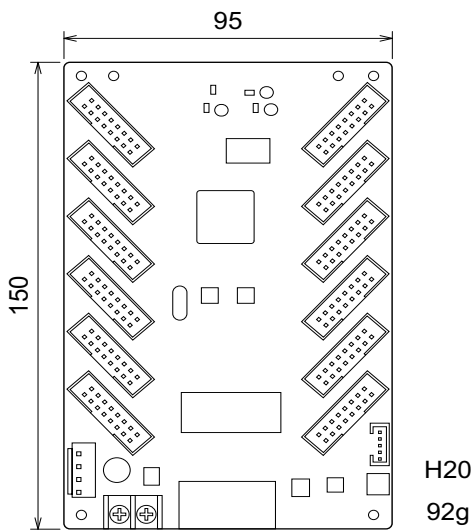

● Switching Power Supply

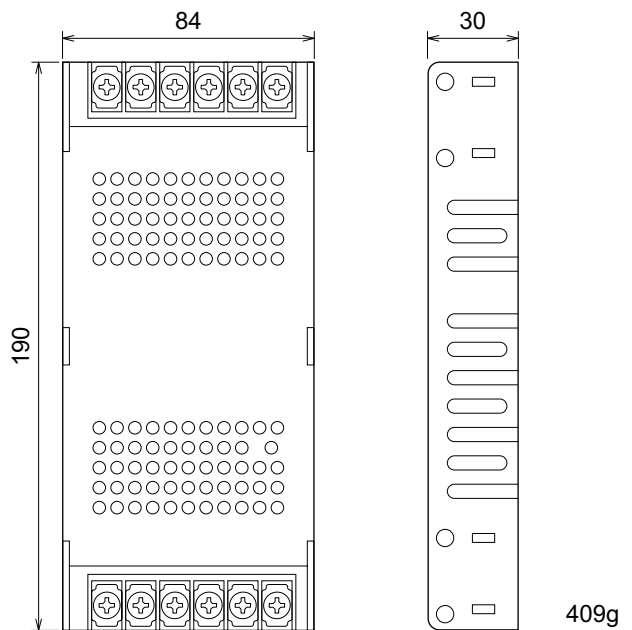

[Size]

Name	Size(mm)	Weight(g)
Module 240	H120 x W240 x D5.5	149
Module 320	H160 x W320 x D5.5	265
Receiving Card	H95xW150x20	92
Switching Power Supply	H84xW190x30	409

4. Specifications

Pixel Pitch(mm)	1.25	1.568	2	2.5	3
LED Type	SMD1010	SMD/GOB1212	SMD/GOB1515	SMD/GOB1515	SMD1515
Pixel Density (Pixels/m ²)	640000	406406	25000	160000	105625
Brightness(cd/m ²)	500-800				
Scan	1/64	1/51	1/40	1/32	1/32
Refresh Rate (Hz)	3840				
Cabinet Size(mm)	Adjustable				
Module Size(mm)360*160					
Vertical/Horizontal	$\geq 140^\circ$ / $\geq 140^\circ$				
Grayscale	16				
Protection Level	IP40				
Color Temperature	3200 ~ 9300K				
Input Signal	HDMI、DVI/VGA、RGBHV、Composite、S-VIDEO、YPbPr(HDTV)				
Module Resolution(W*H)	288*128	229*102	180*80	144*64	120*53
Max.P.C(W/piece)	34.56				
Agv.P.C(W/piece)	14.4				

User Guide

The Flex Series consists of modules that offer limitless expansion driven by your creativity. These LEDs can be installed in 3D configurations, including flat and curved surfaces, through a wide variety of construction methods. We design and propose the ideal installation approach tailored to your specific location and project scale.

1. LED Cabinet

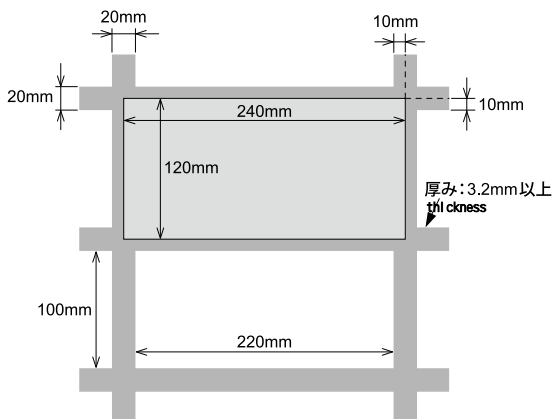

- The enclosure used to mount the modules, receiving cards, and switching power.
- Since modules are installed using magnets, we recommend a cabinet made of steel or SUS400-series stainless steel.
- For standard steel, a plate thickness of 3mm or more is recommended for the mounting surface to ensure the magnets provide sufficient holding power.

When installing on a curved surface, the maximum diameter relative to the display surface varies depending on the module size.

When installing a grid-style cabinet, ensure a rear clearance of at least 65mm.

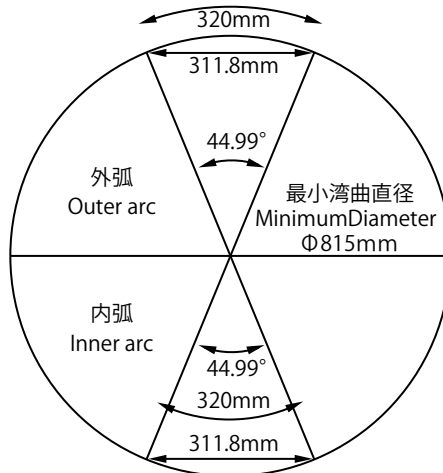
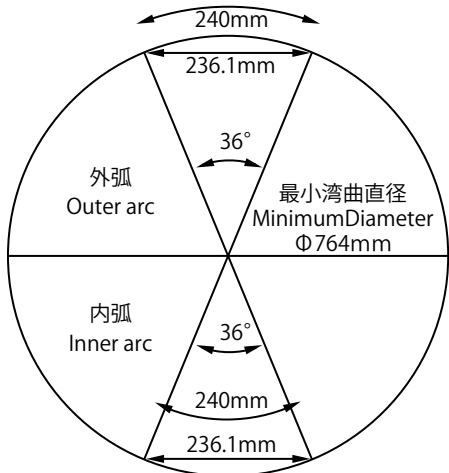
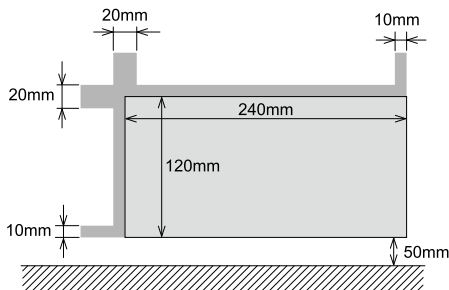
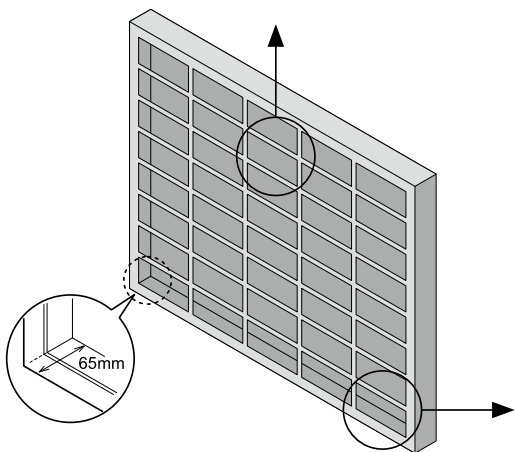

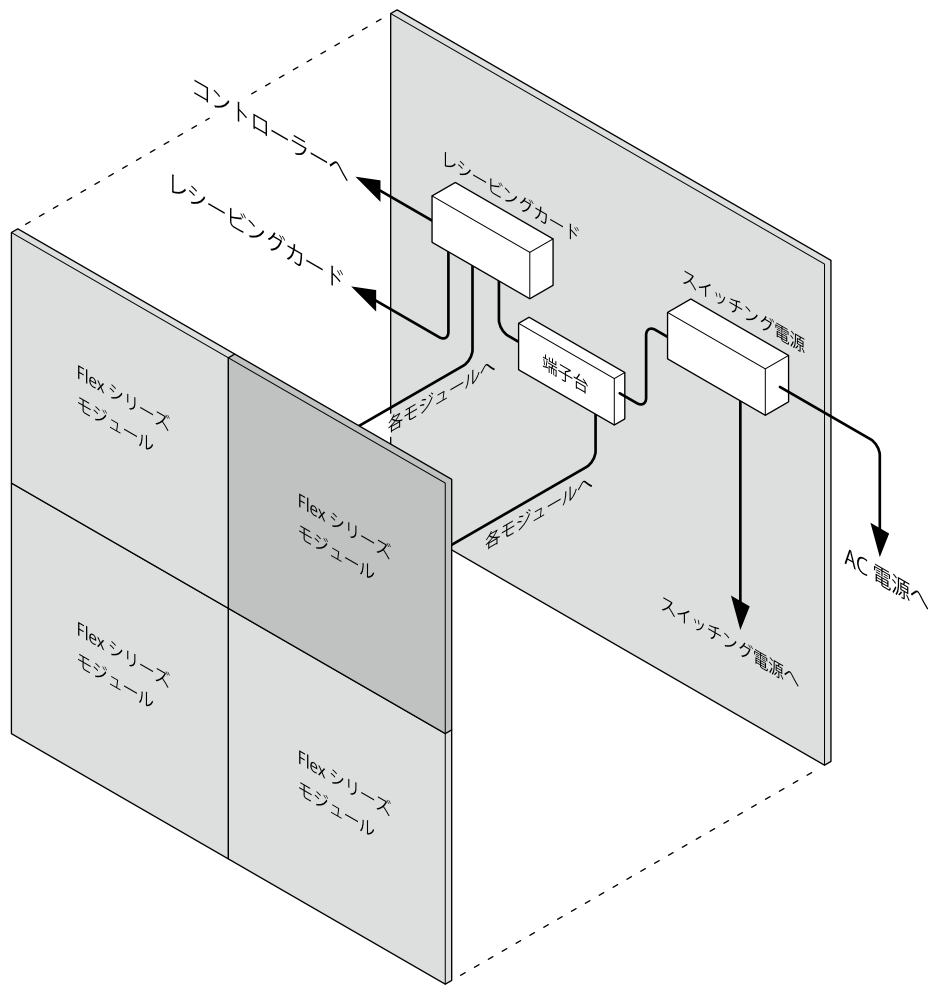

2. Switching Power Supply

Mount switching power supply considering heat, noise, and wiring.

Power supply model and quantity depend on LED load calculation.

Heat affects power supply lifespan and reliability.

Proper heat-dissipating installation is important.

- ① Arrange to optimize natural airflow and convection.
- ③ Leave enough space between multiple power supplies.
- ④ Transfer heat to the chassis or heat sink.
- ⑤ Use fans to improve heat dissipation.

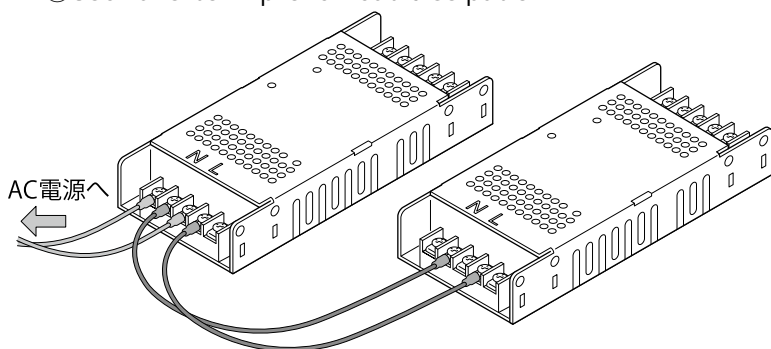

Connect switching power supplies in series.

Do not exceed rated current when connecting multiple units.

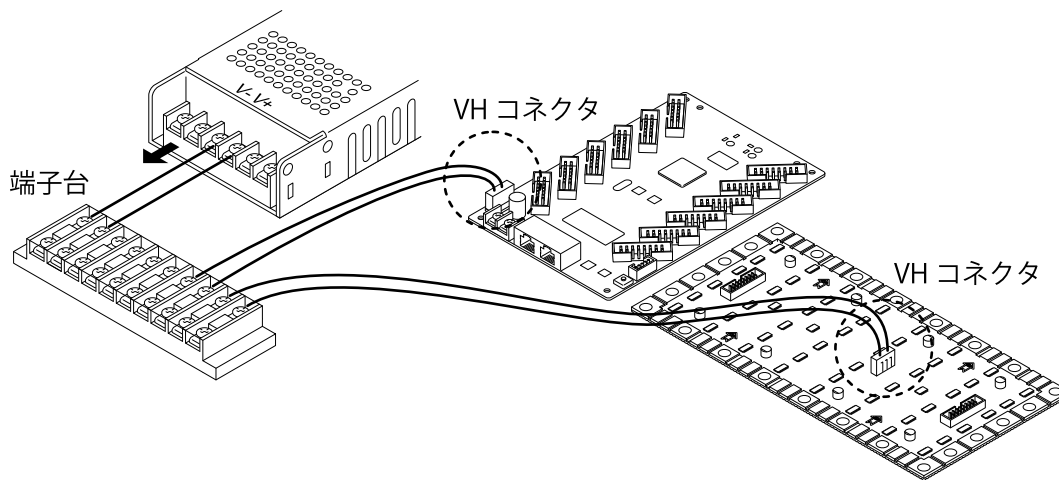

3. Module power cable

Connect Y-type terminal to power supply and supply two modules via VH connector.

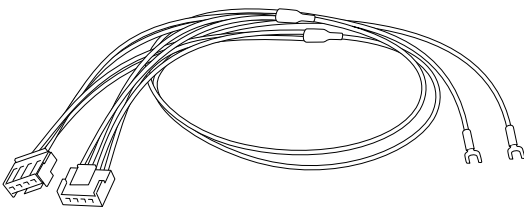

- Input/output power lines can be noise sources. Do not bundle power and signal lines; may cause noise and malfunction.

Keep power and signal lines separate or use shielded cables.

- Wiring loops may generate magnetic fields causing noise. Avoid wiring loops.

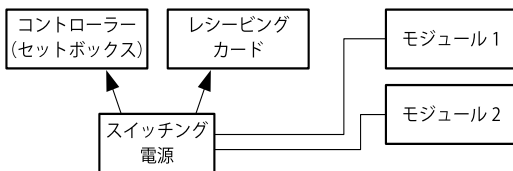

4. Receiving Card

Mount receiving card away from power supply for heat and noise control.

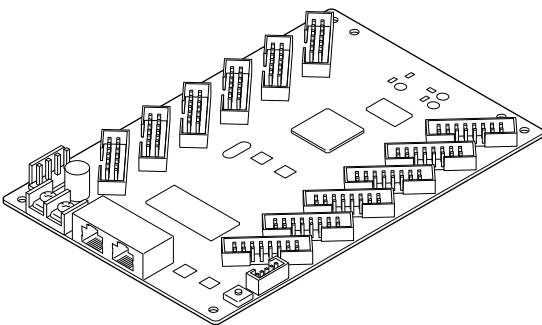

- Board that sends MCU signals to modules and controls LEDs.
- By connecting RJ45 cables (LAN cables) from the controller in a daisy-chain configuration (cascading), it is possible to synchronize and control multiple receiving cards simultaneously.

5. HUB75E cable

The receiving card transmits video signals to each module.

Connect modules and receiving cards in order from top left (1, 2, 3...).

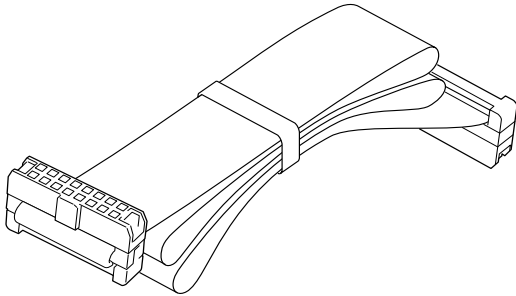

- Uses 2-row 16-pin MIL connector; flat or discrete wires allowed (**max 1000mm**).
- Locked and non-locked types may be mixed; no issue in use.
(**Both modules and receiving cards work with or without locks.**)

6. RJ45 cable

Connect receiving cards using standard LAN cable.

Uses LAN cable but not Ethernet compatible; cannot use switches/hubs.

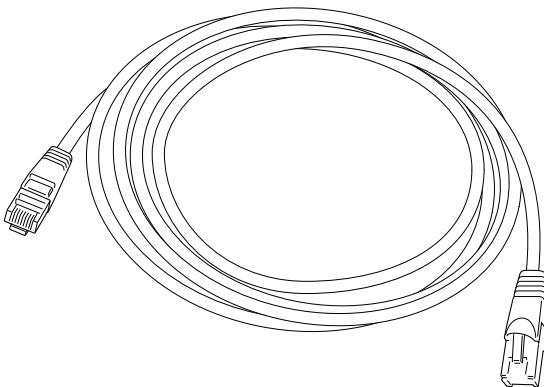

- Connect RJ45 cable from controller to receiving card.
- Daisy-chain receiving cards for synchronized control.

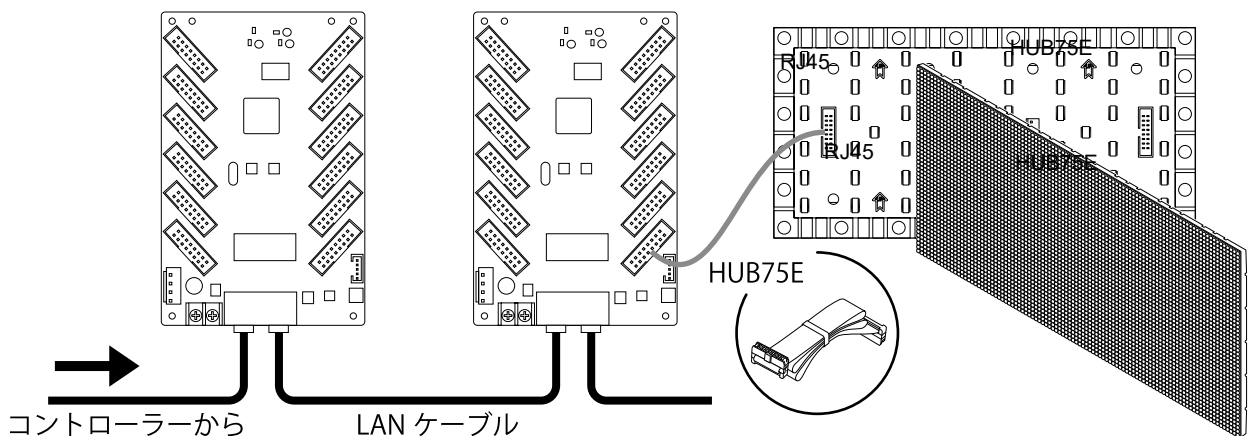
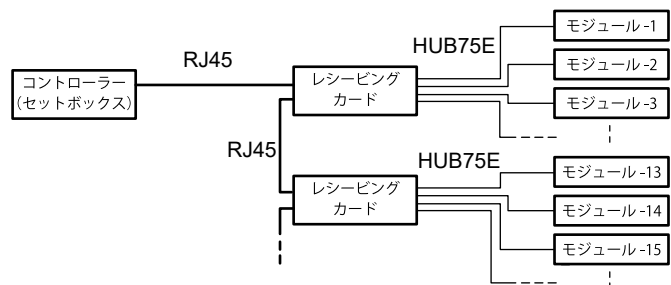

7. Module

The modules come in two sizes: 240 x 120 mm and 320 x 160 mm. Magnets on the back of the modules allow them to easily attach to cabinets. The modules are flexible and can be installed even on curved cabinets. The modules can be arranged vertically and horizontally to expand into large-screen displays, offering flexible configurations.

Connect HUB75E and power cables and align modules precisely.

