

PRANCE







PRANCE[®]
METAL CEILING & FAÇADE SOLUTIONS

ALUMINUM PROFILE

BUILDING MATERIAL
DESIGN FOR YOU

PRANCE METALWORK BUILDING MATERIAL CO.,LTD

Facebook  / LinkedIn  : Prance Metalwork Building Material
Instagram  / YouTube  / Pinterest  : prance_metalwork
Http: //www.prancebuilding.com Tel: +86-757-83138155
E-Mail: info@prancebuilding.com Fax: +86-757-83139722

Office: 3F,1st Building,No.11 Gangkou Rd,Chancheng,Foshan,Guangdong.

Factory: 169, South Area, Base of Electrical and Electronic Industry,Baini, Sanshui, Foshan, Guangdong.

PRANCE METALWORK BUILDING MATERIAL CO.,LTD



COMPANY INTRODUCTION



100+

Production Equipment



2,000+ m²

Showroom



36,000+ m²

Manufacturer



30+

Technical Team Member



40+

Service Team Member

PRANCE METALWORK BUILDING MATERIAL CO.,LTD, established in 2002, is located in the "South Zone of the National Torch Plan Foshan Electronic and Electrical Industry Base" in Baini Town, Sanshui District, Foshan City. It is a manufacturing enterprise specializing in the research and development, production, sales, and technical services of metal ceiling & curtain wall systems and BIPV photovoltaic prefabricated houses.

The company's metal ceiling & curtain wall systems are widely used in public buildings such as airports, high-speed rail (subway) stations, hospitals, schools, stadiums, hotels, and commercial buildings for ceiling and facade applications. The PRANCE team provides comprehensive one-stop solutions, including detailed design, production, and installation guidance. Additionally, the company produces low-carbon BIPV photovoltaic glass for prefabricated houses, offering innovative design, manufacturing, camp solutions, and low-carbon initiatives.



MOLD WORK SHOP



ALUMINUM PROFILE PRODUCTION



APPLICABLE PLACE 适用场所

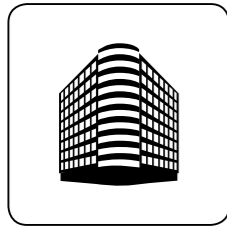

Engineering construction
工程建筑

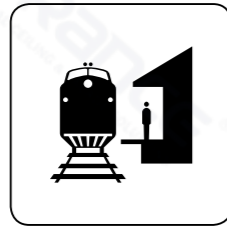

High speed railway station
高铁车站



Airport
机场

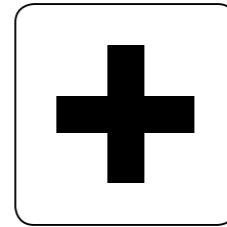

Hospital
医院

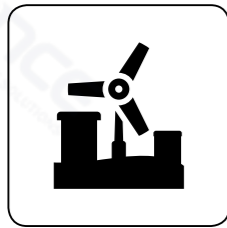

Public place
公共场所



Supermarket
超市



Shopping Mall
购物中心



School
学校



Dance studio
舞蹈室



Hotel
宾馆

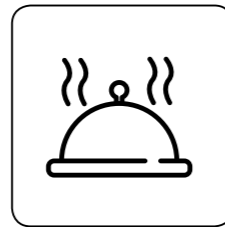

Restaurant
餐厅

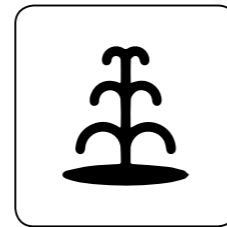

Park
公园



Residence
住宅

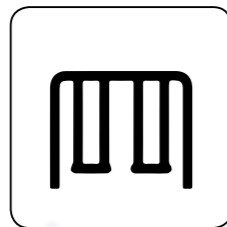

Public facilities
公共设施



Sports field
运动场

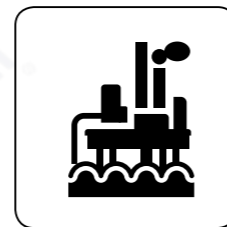

Factory
工厂

PRODUCT CATALOG 产品目录

WAVE PLATE GREAT WALL SERIES 波浪板 - 长城板系列	01-38
CEILING SERIES 天花系列	39-50
ROUND TUBE SERIES 圆吊管系列	51-53
BULLEF SERIES 子弹头系列	54-55
DRIP HANGING PIECE SERIES 水滴挂片系列	56-56
COMBINED PIPE SERIES 组合管系列	57-65
GROOVE PIPE SERIES 槽管系列	66-78
CLASSICS SERIES 经典系列	78-78
ALUMINUM ART SERIES 铝艺系列	79-88
LOUVER SERIES 百叶系列	89-92
ANCHOR LINE SERIES 地脚线系列	93-94
STIFFENER SERIES 加强筋系列	95-101
SQUARE TUBE SPECIFICATION 方管规格	102-109
ROUND TUBE SPECIFICATIONS 圆管规格	110-111
ANGLE ALUMINUM SPECIFICATION 角铝规格	112-113
FLAT BAR SPECIFICATIONS 扁条规格	114-114
CORNER ALUMINUM SPECIFICATIONS 封盖规格	114-114



WAVE PLATE GREAT WALL SERIES

波浪板 - 长城系列



WAVE PLATE GREAT WALL SERIES

After spraying, the surface of aluminum profiles has a very beautiful appearance and is resistant to dirt. Once coated with oil, it is very easy to clean. When assembling the finished product, different specifications of profiles are used according to different load-bearing capacities, and it adopts aluminum profile accessories with accompanying drawings, which do not require welding and are more environmentally friendly. Moreover, installation and disassembly are lightweight, easy to carry, and extremely convenient to move.

铝型材表面经过喷涂后，外观非常漂亮，且耐脏，一旦涂上油污非常易清洁，组装成品时，根据不同的承重采用不同规格的型材，并采用配图铝型材配件，不需要焊接，较环保，而且安装、拆卸，轻巧便于携带、搬移极为方便。

波浪板 - 长城系列 WAVE PLATE - GREAT WALL SERIES >>>

GN 1049 T= 2.0 MM	GN 2276 转角 T= 2.0 MM
GN 8018 T= 1.8 MM	GN 2561 T= 1.5 MM
GN 2318 T= 2.8 MM	GN 3318 T= 2.0 MM
GN 3443 T= * MM	GN 1271 T= * MM
GN 8998 T= 1.1 MM	GN 3337 T= * MM
GN 3359 T= 1.8 MM	GN 3359 T= 1.8 MM

GN 1701 T= 1.8 MM	GN 2373 T= 1.8 MM
GN 1704 T= 1.5 MM	GN 0256 T= 1.2 MM
GN 1622 T= 1.2 MM	GN 1788 T= 1.5 MM
GN 9988 T= 1.5 MM	GN 1725 T= 1.0 MM
GN 1600 T= 1.8 MM	GN 3509 T= 2.0 MM

GN 1521 T= 1.4 MM	GN 2509 T= 1.0 MM
GN 8088 T= 1.5 MM	GN 2926 T= 1.2 MM
GN 8128 T= 2.0MM	GN 2316 T= 1.0/1.2 MM
GN 8801 T= 1.2 MM	GN 8802 T= 1.8 MM
GN 1758 T= 1.5 MM	GN 8879 T= 1.8 MM

GN6007 T= 1.5 MM	GN2350 T= 2.5 MM
GN 2484 T= 1.1 MM	GN 2774 T= 0.9 MM
GN 2670 T= 1.6 MM	GN3402 T= 1.0 MM
GN 2186 T= 1.5 MM	GN 2359 T= 1.5 MM
GN 2599 T= 2.0 MM	GN 1886 T= 2.0 MM

GN3403 T= 1.8 MM	GN3436 T= 1.8 MM
GN3437 T= 2.0 MM	GN3438 T= 2.0 MM
GN3555 T= 1.1MM	GN3098 T= 1.5 MM
GN2584 T= 1.2 MM	GN1736 T= 1.2 MM
GN9888 T= 1.5 MM	GN2203 T= 1.2 MM

GN3307 T= 3.0 MM	GN3238 T= 0.8 MM
GN 0716 T= 0.9 MM	GN 1621 T= 0.9 MM
GN9958 T= 1.5 MM	GN2369 T= 1.2 MM
GN6027 T= 1.2 MM	GN3730 T= 1.5 MM
GN 1771 T= 1.0 MM	GN 8808 T= 1.8 MM

GN 2107 T= 1.9 MM	GN 9808 T= 1.8 MM
GN3666 T= 2.0 MM	GN2826 T= 2.0 MM
GN2981 T= 1.5 MM	GN 2317 T= 2.0 MM
GN 2343 T= 2.0 MM	GN 2344 T= 2.0 MM
GN3608 T= 1.2 MM	GN3609 T= 1.0 MM

<p>GN3660 T= 1.8 MM</p>	<p>GN3107 T= 1.5 MM</p>
<p>GN 1693 T= 1.2 MM</p>	<p>GN 8098 T= 1.5 MM</p>
<p>GN 9938 T= 1.5 MM</p>	<p>GN1577 T= 1.1 MM</p>
<p>GN 2106 T= 0.8 MM</p>	<p>GN9878 T= 1.5 MM</p>
<p>GN 0847 T= 1.0 MM</p>	<p>GN3581 T= 1.0 MM</p>

<p>GN 8038 T= 1.0 MM</p>	<p>GN 1448 T= 1.0 MM</p>
<p>GN 8068 T= 1.5 MM</p>	<p>GN 8078 T= 1.5 MM</p>
<p>GN 2999 T= 1.2 MM</p>	<p>GN2559 T=0.9 MM</p> <p>GN2560 T=1.0 MM</p>
<p>GN2715 T= 0.9 MM</p>	<p>GN 8198 T= 1.0 MM</p>
<p>GN3300 T= 1.0MM</p>	<p>GN6039 T= 1.2 MM</p>



GN2140 T= 1.0 MM	GN2419 T= 1.5 MM
GN6074 T= 1.2 MM	GN3450 T= 0.9 MM
GN0591 T= 1.5 MM	GN3358 T= 2.9 MM
GN3688 T= 2.0 MM	GN6037 T= 1.8 MM
GN3882 T= 1.0 MM	GN3419 T= 1.0/ 1.2 MM

GN2376 T= 2.0 MM	GN3538 T= 1.3 MM
GN6035 T= 1.2 MM	GN1298 T= 1.0 MM
GN3165 T= 1.2 MM	GN 1625 T= 1.2 MM
GN 1773 T= 1.2 MM	GN2349 T= 3.0 MM
GN3490 T= 1.0 MM	GN2463 T= 1.8 MM

GN2967 T= 2.0 MM	GN2966 T= 2.0 MM
GN2284 T= 1.8 MM	GN3442 T= 1.2MM
GN 0271 T= 1.3 MM	GN3387 T=1.4MM
GN2408 T= 2.0 MM	GN2611 T=1.5 MM
GN3053 T= 1.8 MM	GN3052 T= 1.8 MM

GN2866 T= 1.2 MM	GN 2074 T= 1.3 MM
GN 1314 T= 1.3 MM	GN 9708 T= 0.8 MM
GN 8158 T= 1.2 MM	GN 1313 T= 1.3 MM
GN2270 T= 1.3 MM	GN 9868 T= 0.9 MM
GN 2445 T= 1.3 MM	GN2245 T= 1.4 MM



GN 1312 T= 1.3 MM	GN3459 T= 1.2 MM
GN2135 T= 2.2 MM	GN 2612 T= 2.2 MM
GN 9858 T= 1.0 MM	GN 1283 T= 1.3 MM
GN 8138 T= 1.2 MM	GN 8058 T=1.3 MM
GN 9828 T= 1.2 MM	GN3658 T= 1.8 MM

GN 9838 T= 1.3 MM	GN3496 T= 1.0 MM
GN2960 T= 1.2 MM	GN2645 T= 1.3 MM
GN3079 T= 1.0 MM	GN-JH001 T= 1.3 MM
GN3475 T= 3.0 MM	GN2356 T= 1.3 MM
GN2360 T= 1.3 MM	GN2409 T= 2.0 MM



GN2845 T= 1.0 MM	GN 1326 T=0.8/1.0 MM
GN2968 T= 1.0 MM	GN 8008 T= 1.2 MM
GN 1768 T= 1.2 MM	GN2650 T= 1.0 MM
GN 8888 T= 0.8 MM	GN 2009 T=1.2 MM
GN3474 T= 3.0 MM	GN3678 T= 1.1 MM

GN2134 T= 1.5 MM	GN 2010 T= 1.4 MM
GN2256 T= 1.9 MM	GN 8178 T= 1.5 MM
GN 8188 T= 1.5 MM	GN3585 T= 1.0 MM
GN6688 T= 1.7 MM	GN3668 T= 1.1 MM
	GN2975 T= 1.5 MM



<p>GN3735 T= 1.2 MM</p>	<p>GN1550 T= 1.0 MM</p>
<p>GN2325 T= 1.3 MM</p>	<p>GN2030 T= 2.0 MM</p>
<p>GN3445 T= 2.0 MM</p>	<p>GN3091 T= 1.3 MM</p>
<p>GN2838 T= 1.8 MM</p>	<p>GN3062 T=1.1 MM</p>
<p>GN2114 T= 1.2 MM</p>	<p>GN1528 GN1529 T= 2.0 MM</p>

<p>GN8168 T= 1.2 MM</p>	<p>GN9738 T= 1.5 MM</p>
<p>GN0261 T= 1.1 MM</p>	<p>GN1680 T= 1.0 MM</p>
<p>GN2382 T= 2.4 MM</p>	<p>GN3470 T= 2.5 MM</p>
<p>GN3549 T= 0.8 MM</p>	<p>GN2699 T= 1.4 MM</p>
<p>GN2348 T= 3.0 MM</p>	<p>GN2683 T= 1.4 MM</p>



GN 1606 T= 2.0 MM	GN 2108 T= 1.8 MM
GN 2470 T= 1.8 MM	GN 1386 T= 1.8MM
GN 1459 T = 1.1 MM	GN 1427 T= 1.1 MM
GN 2460 T=1.5 MM	
GN 2419 T= 1.5 MM	GN 2460 T= 1.5 MM
	GN 2419 T= 1.5 MM

GN 1321 T= 1.0 MM	GN 1334 T= 1.2 MM
GN 2232 T= 1.5 MM	GN 2251 T= 1.4 MM
GN 2255 T= 1.4 MM	GN 2307 T= 1.8 MM
GN 6070 T= 1.5 MM	
GN 3659 T= 1.8 MM	GN 2216 T= 2.0 MM



GN 1518 T= 1.0 MM	GN 9928 T= 1.5 MM
GN 1774 T= 1.5 MM	GN1774 T= 1.5 MM
GN 1775 T= 1.1/1.5 MM	GN1775 T= 1.5 MM
GN 1775 T= 1.1/1.5 MM	GN1775 T= 1.5 MM
GN 1727 T= 1.5 MM	GN 9004 T=1.5 MM
GN 9005 T= 2.5 MM	GN9004 T= 1.5 MM
	GN9005 T= 2.5 MM

GN 1681 T= 3.0 MM	
GN 1682 T= 3.0 MM	GN1681 T= 1.3 MM
GN 1682 T= 3.0 MM	GN1682 T= 1.3 MM
GN 2017 T= 1.5 MM	
GN 2019 T= 1.5 MM	GN2017 T= 1.5 MM
GN 1293 T= 1.4 MM	GN2019 T= 1.5 MM
	GN 7006 T= 2.2 MM

	<p>GN2577 配 GN2578 配 GN6020</p>
GN2577 T= 1.2 MM	GN2578 T=1.4 MM
	<p>GN2577 配 GN2578 配 GN6030</p>
GN6020 T= 1.2 MM	
	<p>GN2577 配 GN2578 配 GN6050</p>
GN6030 T= 1.5 MM	
	<p>GN2577 配 GN2578 配 GN6057</p>
GN6050 T= 1.2 MM	
GN6057 T= 1.2 MM	

GNTW-028 T=1.5/1.7 MM	GN 1738 T= 1.5 MM
GNTW-028 T= 1.7 MM	GN2191 T = 1.7 MM
GN8898 T= 1.5 MM	GN2492 T= 1.9 MM
GN6038 T= 1.8 MM	GN7208 T= 2.0 MM
GN5008(接近) T= 1.8 MM	GN2155 T= 1.5 MM
GN 8028 T= 1.2 MM	



<p>GN2577 T=1.2 MM</p>	<p>GN2578 T=1.4 MM</p>
	<p>GN2577 配 GN2578 配 GN6031</p>
<p>GN6031 T= 1.5 MM</p>	
<p>GN 8868 T= 1.4/1.8 MM</p>	<p>GN 2279 T= 1.2 MM</p>
<p>GN 7007 T= 2.2 MM</p>	<p>GN3602 T=1.2 MM</p>
<p>GN3470-YJ2022-1 T= 1.0 MM</p>	

<p>GN 1747 T = 1.4 MM</p>	<p>GN 1128 T= 1.5 MM</p>
<p>GN 1129 T= 1.5 MM</p>	<p>GN 1130 T= 1.5 MM</p>
	<p>GN2018 配 GN1130 组装</p>
<p>GN 2018 T= 1.4 MM</p>	
<p>GN 1108 T= 1.0/1.4 MM</p>	<p>GN 2018-A T= 1.8 MM</p>
<p>GN 3203 T= 2.0 MM</p>	<p>GN 3303 T= 1.4 MM</p>

GN 2682 T= 1.8 MM	GN 1045 T= 2.0 MM
GN 1466 T= 2.0 MM	GN 2035 T= 2.5 MM
GN 1384 T= 1.2 MM	GN2156 T= 1.2 MM
GN 2473 T= 1.1MM	GN 9003 T= 1.5 MM
GN 1246 T= 1.1 MM	GN3553 T= 1.4 MM

GN 3540 T= 1.2 MM	
GN3541 T= 1.2 MM	
GN3542 T= 1.2 MM	
	GN8108 T= 1.2 MM
	GN2557 T= 1.0 MM
	GN2556 T= 1.8 MM
	GN3591 T= 1.1 MM



GN3061 T= 1.1 MM	GN3503 T= 1.8 MM
GN3824 T= 1.4 MM	GN3825 T= 1.4 MM
GN3848 T= 0.9 MM	GN3853 T= 1.4 MM
GN3279 T= 1.0 MM	GN3740 T=1.0 MM
GN3661 T= 1.2 MM	GN1212 T= 1.2 MM

GN2367 T= 1.2 MM	GN3161 T= 3.0 MM	
GN8118 T= 1.2 MM	GN3334 T= 3.0 MM	GN3335 T= 3.0 MM
GN3160 T= 1.0 MM	GN2368 T= 1.2 MM	
GN3778 T=1.7MM	GN9998 T= 1.5 MM	
GN1531 T= 0.9/1.1 MM	GN2731 T= 2.0 MM	



GN2483 T= 1.1 MM	GN 1729 T= 1.0 MM
GN 9002 T= 3.0 MM	GN2876 T=1.8 MM
GN 1578 T= 3.0MM	GN2580 T= 3.0 MM
GN 1974 T= 3.0 MM	GN 9978 T= 1.5 MM
GN 1123 T= 1.3 MM	GN5030 T= 1.9 MM

GN3767 T= 1.2 MM	GN3768 T=1.8 MM
GN3775 T= 1.0 MM	GN3878 T= 2.0 MM
GN3888 T= 2.0 MM	GN3898 T=2.0 MM
GN3777 T= 1.4MM	GN3808 T= 2.0 MM
GN3858 T= 2.0 MM	GN3868 T= 2.0 MM

GN5008 T= 1.5 MM	GN6038(接近) T= 1.3 MM
GN3827 T= 2.9 MM	GN3828 T= 2.9 MM
GN3829 T= 2.9 MM	GN3908 T= 1.0 MM
GN3918 T= 1.2 MM	GN3167 T=1.0 MM
GN5051 T= 1.5 MM	GN8882 T=1.2 MM

GN3928 T= 2.0 MM	GN3938 T= 2.0 MM
GN3948 T= 2.0 MM	GN3958 T= 2.0 MM
GN3968 T= 2.0 MM	GN3978 T= 2.0 MM
GN3984 T= 1.1 MM	GN5001 T= 1.0 MM
GN5050 T= 1.3 MM	GN5052 T= 1.5 MM

GN5138 T= 2.0 MM	GN5132 T= 0.9 MM
GN5140 T= 1.0 MM	GN5141 T= 1.0 MM
GN5142 T= 1.0 MM	GN5174 T= 1.2 MM
GN5175 T= 1.2 MM	GN5176 T= 1.2 MM
GN5177 T= 1.2 MM	GN5178 T= 1.2 MM

GN5518 T= 1.8 MM	GN5528 T= 1.8 MM
GN5538 T= 1.8 MM	GN5548 T= 1.8 MM







10 系列 			15 系列
GN 0760 T=0.7 MM	80X10TH T=0.9 MM	100X10TH T=1.0 MM	GN 0814 T=1.0 MM
			20 系列
GN 60X15TH T=1.1 1.8 MM	GN 0992 T=0.8/1.8MM	GN 1444 T=1.2 1.5 MM	GN 0926 T=1.2 MM
GN 40X20TH T=0.7/0.8/0.9/1.3 MM	GN 50X20TH T=0.7/0.9/1.2/1.4 MM	GN2616 T=2.0 MM	GN 60X20TH T=0.8/1.0/1.2/1.3 MM
GN3600 T=0.8 MM	75X20TH T= 1.2 MM	GN80X20TH T=0.8/1.0/1.2 MM	GN3794 T=0.9 MM
GN 100x20TH T=0.8/0.9/1.0/1.2/1.4 MM	GN3563 T= 0.7 MM	GN 120x20TH T=1.0/1.2/2.0 MM	GN2137 T= 1.0 MM

GN150X20TH T=0.9/1.0/1.2/1.5 MM	GN2617 T=1.5 MM	GN 180X20TH T=1.6 MM	GN 200X20TH T= 1.5/1.6/2.0MM
		25 系列 	
GN 200X20TH T= 1.3/1.5 MM	GN 0837 T= 2.2 MM	GN 50X25TH T=0.7/0.8/0.9/1.0/1.1/1.2/1.4 MM	GN 1938 T=1.0 MM
GN 60X25TH T= 0.7/1.0/1.2 MM	GN 70X25TH T=0.8/0.9/1.2 MM	GN 75X25TH T= 0.8/0.9/1.0/1.2 MM	GN 80X25TH T= 0.8/0.9/1.0/1.2/1.4MM
GN 100X25 T=0.8/0.9/1.0/1.2/1.5/1.8/2.0MM	GN 1483 T=1.0/1.2MM	GN1893 T=1.0 MM	GN2820 T=3.0 MM
GN 120X25TH T=0.8/0.9/1.1/1.2/1.5/1.8MM	GN 150X25TH T=0.8/1.0/1.3/1.5/1.8 MM	GN 200X25TH T= 1.5/1.6/2.0MM	GN3776 T=1.5 MM

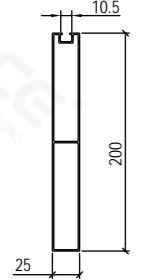
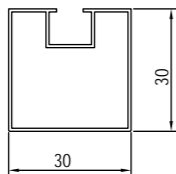
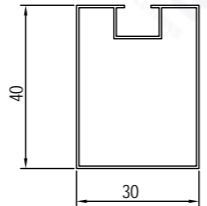
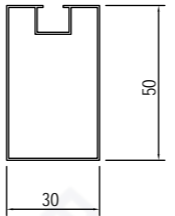
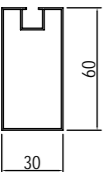
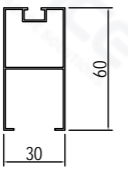
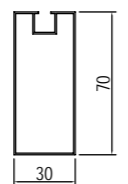
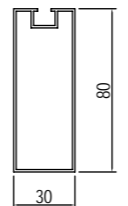
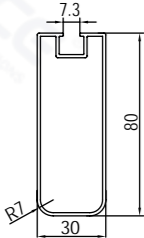
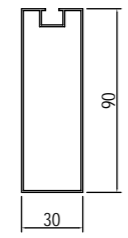
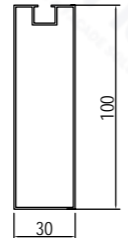
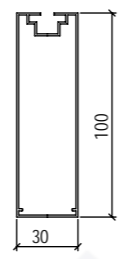
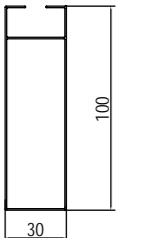
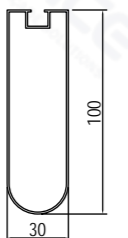
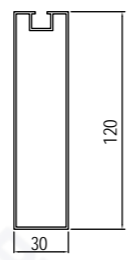
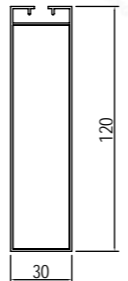
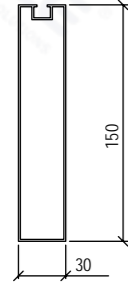
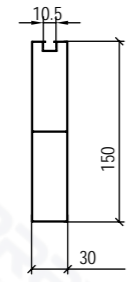
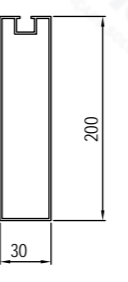
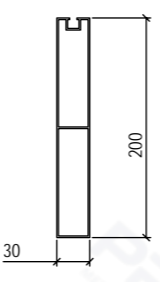

	30系列 		
GN 200x25TH T=1.3 MM	30X30TH T=0.7 MM	GN 40X30TH T=0.7/0.8/1.0/1.2/1.5/1.8 MM	GN 50X30TH T=0.6/0.8/0.9/1.0/1.2/1.5 MM
			
GN 60X30TH T=0.7/0.8/1.0/1.2/1.5/1.8MM	LC-GN0745 T=0.8 MM	GN 70X30TH T=0.8/0.9/1.0/1.2/1.5/1.8MM	80X30TH T=0.7/0.8/1.0/1.2/1.5/1.8/2.0MM
			
GN3723 T=1.5 MM	GN 90X30TH T=0.8/0.9/1.2/1.5MM	GN 100X30TH T=0.7/0.8/0.9/1.0/1.2/1.5/2.0/2.5MM	GN 1574 T=1.2 MM
			
GN 0103 T= 1.0/1.2 MM	GN 1591 T=1.0 MM	GN 120X30TH T= 0.8/0.9/1.0/1.1/1.2/1.5/1.8MM	GN2714 T=1.1 MM
			
GN 150X30TH T=1.0/1.2/1.4/1.5/1.8/2.0/2.5MM	GN 150X30TH T=0.8 MM	GN 200X30TH T=1.5/1.8/2.0 MM	GN 200X30TH T= 1.3/1.6 MM

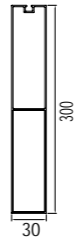
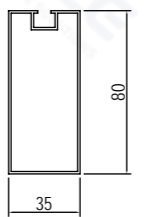
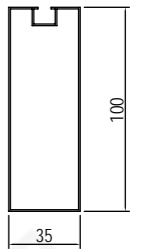
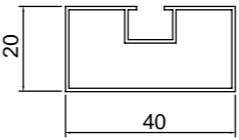
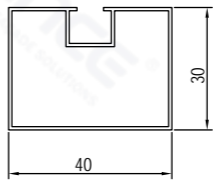
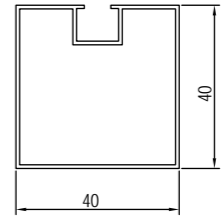
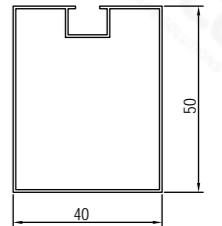
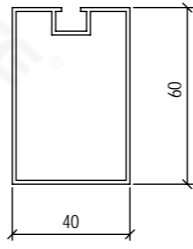
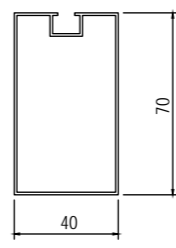
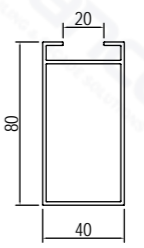
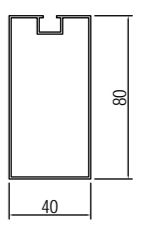
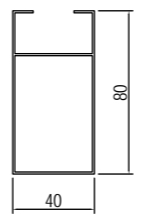
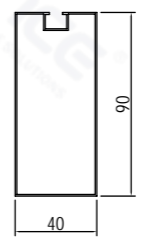
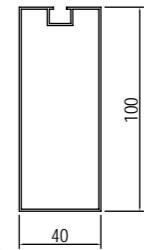
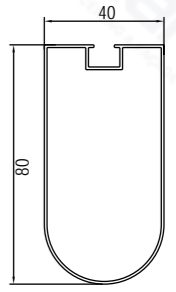
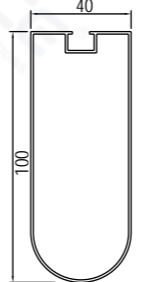
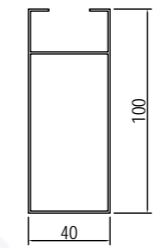
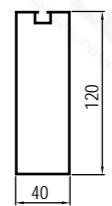
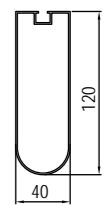
		35系列 	
GN250X30 T= 1.8 MM	GN300X30 T= 2.0 MM	GN 80X35TH T=1.2 MM	GN 100X35TH T= 0.8/1.0/1.2 MM
40系列 			
GN 20X40TH T=0.8/1.0/1.3/1.5 MM	GN 30X40TH T=0.8/1.0/1.2 MM	GN 40X40TH T=0.7/0.8/0.9/1.0/1.2/1.5/1.8 MM	GN 50X40TH T= 0.7/0.9/1.0/1.2/1.5/1.8/3.0 MM
			
60X40TH T=0.8/1.0/1.2/1.3/1.8 MM	70X40TH T=0.8/0.9/1.0/1.2/1.5MM	GN2305 T= 1.7 MM	80X40TH T=0.7/0.8/0.9/1.0/1.2/1.3/1.5/1.8MM
			
GN1482 T= 1.0/1.2MM	90X40TH T=0.7/0.8/0.9/1.0/1.1/1.2/1.5/1.8MM	GN 100X40TH T=0.7/0.8/0.9/1.0/1.1/1.2/1.5/1.8/2.0MM	GN2873 T= 0.9 MM
			
GN2874 T= 1.0 MM	GN 1485 T= 1.0/1.2 MM	120X40TH T=0.8/0.9/1.0/1.2/1.5/1.8/2.0 MM	GN 2011 T= 1.1 MM



125X40TH T=1.1MM	150X40TH T= 1.1/1.2/1.5/1.8/2.0MM	150X40TH T= 0.9 MM	GN 1991 T= 2.0 MM
		45系列 	
200X40TH T= 1.5/1.8/2.0/2.5 MM	200X40TH T= 1.3 1.5 MM	GN 100X45TH T= 1.4 MM	GN5031 T=0.8MM
GN2277 T= 1.1 MM	GN 30X45TH T= 1.5 MM	30X50TH T=0.8/1.0/1.2/1.4MM	40X50TH T= 0.8/1.0/1.2 MM
45X50TH T= 1.5 MM	50X50TH T=0.6/0.8/0.9/1.0/1.1/1.2/1.5/1.8/2.0/2.5/3.0MM	GN 2012 T= 0.9MM	GN2558 T= 1.9 MM
GN2740 T= 1.4 MM	GN 2249 T= 1.0/2.5 MM	70X50TH T= 0.8/0.9/1.0/1.2/1.5/1.8 MM	75X50TH T= 1.0 MM

GN 80X50TH T= 0.7/0.8/1.0/1.2/1.5/1.8/2.0 MM	GN 1487 T= 1.0 MM	GN5016 T=0.9 MM	GN 90X50TH T=0.7/0.8/0.9/1.0/1.1/1.2/1.5/1.8/2.0MM
GN 2333 T= 1.2 MM	100X50TH T=0.7/0.8/0.9/1.0/1.1/1.2/1.5/1.8/2.0/2.5/3.0MM	GN 1486 T= 1.0 1.2 1.5 MM	GN2750 T= 2.5 MM
GN3566 T= 1.1 MM	GN 2304 T= 0.9 MM	GN 2250 T= 1.0 MM	GN 0819 T= 1.9 MM
GN2796 T=1.1 MM	GN5038 T= 1.1 MM	GN5048 T= 1.4 MM	GN 120X50TH T=0.9/1.0/1.2/1.3/1.5/1.8/2.0/2.4 MM
GN 2013 T= 1.2 MM	GN2223 T= 1.2 MM	150X50TH T=0.9/1.0/1.2/1.4/1.5/1.8/2.0/2.5MM	GN 2749 T=2.5 MM



GN 1488 T= 1.2/1.5 MM	GN 2014 T= 1.3 MM	GN 0857 T= 2.0 MM	GN5058 T=1.4 MM
GN 1588 T= 1.9 MM	GN5068 T=1.8 MM	GN3837 T=2.4 MM	200X50TH T= 1.5/1.8/2.0/2.4 MM
GN 2282 T=2.2 MM	200X50TH T= 1.3 MM	250X50TH T=2.3 MM	300X50TH T=2.0MM
GN3115 T= 1.8 MM	30X60TH T= 0.8/1.0/1.2 MM	40X60TH T= 0.9/1.1 MM	60X60TH T=0.8/0.9/1.0/1.2/1.5/1.8 MM
80X60TH T=1.0/1.2/1.3/1.5/1.8MM	GN 1684 T=1.2 MM	GN 5187 T= 1.2 MM	GN 1789 T= 1.2 MM

GN 0649 T= 1.2 MM	100X60TH T=0.8/1.0/1.2/1.5/1.8/2.0/2.5 MM	GN 120X60 T=1.0/1.2/1.5/1.8/2.0/2.5 MM	GN 2183 T= 1.8 MM
GN 2400 T=1.4 MM	150X60TH T=1.0/1.2/1.5/1.6/1.8/2.0 MM	GN 1058 T= 1.5 MM	160X60TH T= 1.5/1.6/1.8/2.0MM
200X60TH T= 1.6/1.8/2.0 MM	GN 0997 T= 1.9 MM	70-75系列	160X60TH T= 1.5/1.6/1.8/2.0MM
GN 100x75TH T= 1.2 MM	GN 150x75TH T=1.5/1.8 MM	80系列	GN 120X70TH T= 1.2 MM
GN 100x75TH T= 1.2 MM	GN 150x75TH T=1.5/1.8 MM	GN 35X80TH T=1.2 MM	GN 40X80TH T= 0.8/1.0/1.2 MM
GN 50X80TH T=0.8/1.0/1.2/1.5/2.0 MM	GN 60X80TH T= 0.9/1.0/1.2/1.5 MM	GN 80X80 T=0.9/1.0/1.2/1.3/1.8/2.0 MM	GN3813 T=1.0 MM



GN2760 T=1.1 MM	100X80TH T=1.0/1.2/1.5/1.8/2.0 MM	GN 120X80TH T=1.2/1.4/1.8/2.0MM	GN 1240 T=1.3 MM
GN 150X80TH T= 1.5 1.8 2.0 2.5 MM	GN3377 T= 1.8 MM	GN5078 T=1.8 MM	200X80TH T= 1.8/2.0 MM
		100系列 	
GN5088 T=1.8 MM	250X80TH T= 2.5 MM	GN 50X90TH T=1.0/1.2 MM	GN 30X100TH T=0.9/1.0/1.2 MM
GN3819 T= 1.5 MM	GN 50X100TH T=1.0 1.2 1.5 1.8MM	GN 70X100TH T= 1.2 MM	GN 100X100 TH T=1.0/1.2/1.5/1.8/2.0 MM
JJ-GN1328 T=1.5 MM	GN2292 T= 1.5/1.8 MM	GN 1472 T= 3.0 MM	GN 0869 T=1.9 MM

150X100TH T= 1.3/1.5/1.8/2.0/2.5 MM	GN5098 T= 1.8 MM	GN2775 T= 2.2 MM	GN2136 T= 1.9 / 3.0 MM
200X100TH T=1.5/1.8/2.0/2.2/2.5 MM	GN5108 T=1.8 MM	250X100TH T= 2.3 MM	GN300X100TH T=2.8 MM
120系列 			
GN 50X120TH T= 1.2/1.5MM	100X120TH T=1.6 MM	GN3652 T= 3.0 MM	GN 1059 T= 1.8 MM
150系列 			200系列
GN 50X150TH T= 1.3/1.8 MM	100X150TH T= 2.0/2.5 MM	GN150X150TH T=2.0/2.2 MM	GN50X200TH T=2.0/2.2 MM
	250系列 		
GN 100X200TH T= 2.0/2.2 MM	GN 100X250TH T= 2.5 MM	GN2497 T=0.9 MM	GN2138 T= 1.2/1.8 MM



GN 0265 T=0.6 MM	GN3571 T=0.7 MM	GN3572 T=0.7 MM	GN2552 T=1.5 MM
30系列 			40系列
GN30X50UC T=0.6 0.7 0.9 MM	GN2881 T=0.9 MM	100X30UC T=1.2/1.4/1.8 MM	GN60X40UC T=0.9 MM
		50系列 	
GN80X40UC T=1.2/1.4/1.8 MM	GN100X40UC T=1.2/1.4/1.8 MM	GN3405 T=1.5 MM	GN70X50UC T=2.0 MM
			60系列
GN80X50UC T=1.2/1.4/1.8 MM	100X50UC T=1.2/1.4/1.8 MM	GN2867 T=1.2/1.5/1.9 MM	GN1661 T=1.8 MM
100X25UCTH T=1.4 MM	120X50UCTH T=1.4 MM	120X60UCTH T=1.4 MM	150X30UCTH T=1.4 MM

150X40UCTH T=1.4 MM	150X50UCTH T=1.4 MM	150X60UCTH T=1.4 MM	



APPLICATION SCOPE 应用范围

用于隐蔽工程繁多人流密集的公共场所，便于空气的流通、排气、散热的同时，能够使光线分布均匀，使整个空间宽敞明亮。广泛应用于地铁，高铁站，车站，机场，大型购物商场，通道，休闲场所，公共卫生间，酒店，学校餐厅，建筑物外墙等开放式场所。

Used in public places with numerous concealed projects and dense pedestrian flow, it facilitates air circulation, exhaust, and heat dissipation, while also distributing light evenly, making the entire space spacious and bright. Widely used in open spaces such as subways, high-speed rail stations, stations, airports, large shopping malls, corridors, leisure places, public restrooms, hotels, school restaurants, and building facades.

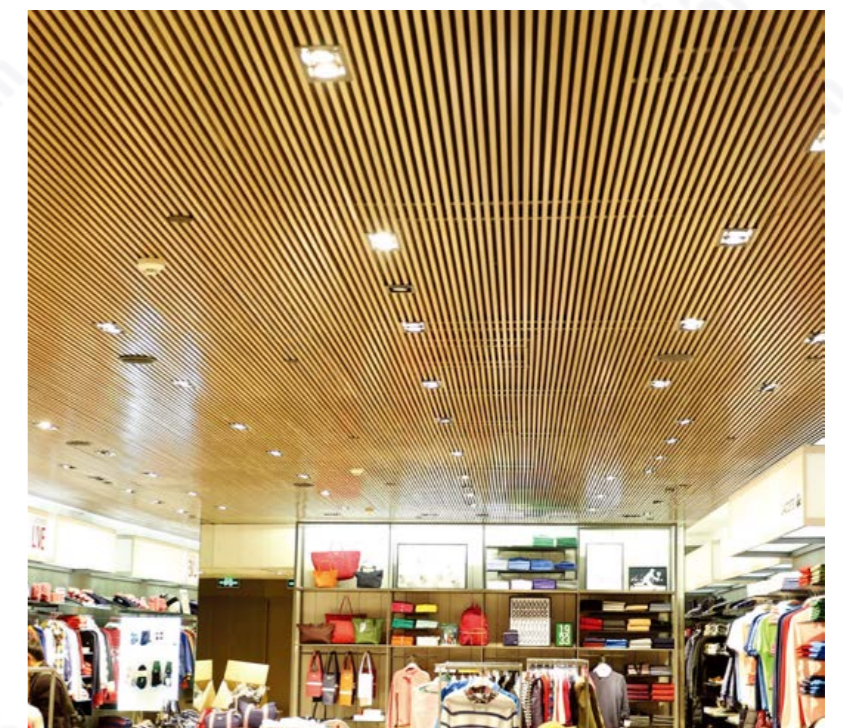

ROUND TUBE SERIES

圓管系列

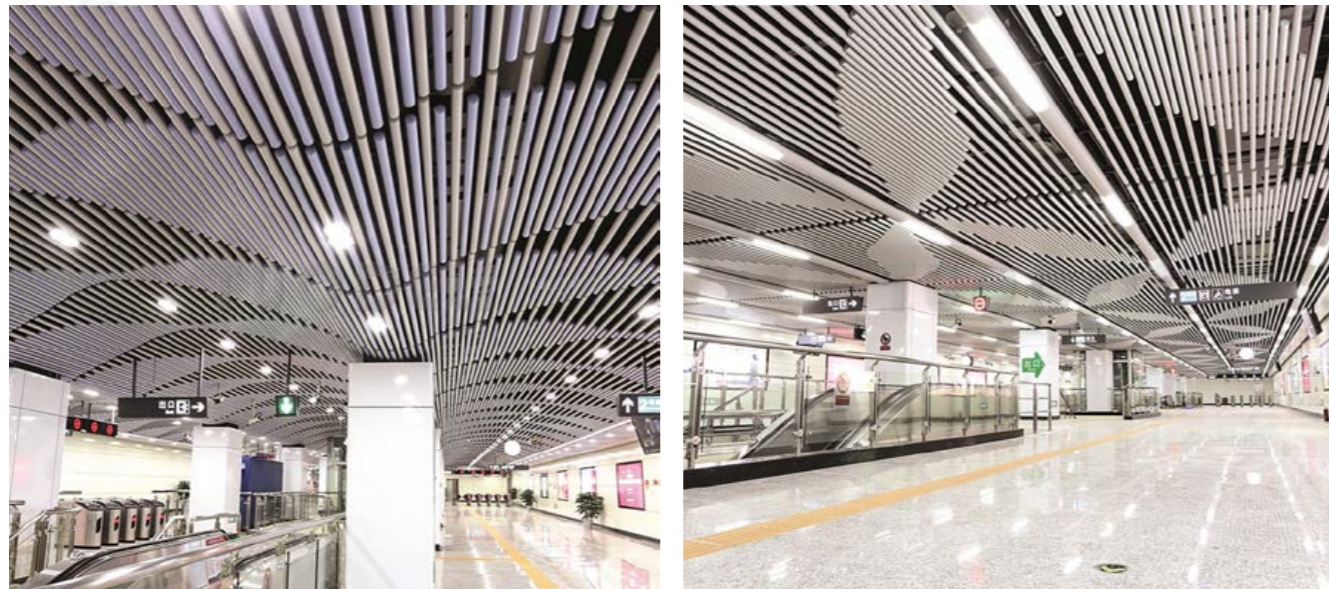

GN25TH T= 0.8/1.0 MM	GN30 T=0.7/0.8/0.9/1.0 MM	GN30ACTH T=0.7 MM	GN 1369 T= 1.5 MM
GN 1412 T= 1.0 MM	GN40ACTH T=0.7 MM	GN40TH T=0.7/0.8/0.9/1.0/1.1/1.2/1.4 MM	GN 1370 T= 1.2 MM
GN2161 T= 0.7 MM	GN1244 T=1.1 MM	GN45ACTH T=1.0 MM	GN50YGTH T=0.7/0.8/0.9/1.0/1.1/1.2/1.4/1.8 MM

圓管系列 ROUND TUBE SERIES



GN50ACTH T=0.7/0.8/0.9/1.0/1.1/1.2/1.4 MM	GN2766 T= 0.8/1.6 MM	GN60TH T=0.8/0.9/1.0/1.2/1.4 MM	GN60ACTH T=0.8/1.0/1.2 MM
GN 60AC TH T= 0.8 MM	GN2885 T=1.0 MM	GN 70TH T= 1.0/1.2/1.4 MM	GN 70TH T= 1.2 MM
GN5240 T= 0.7/0.9/1.1 MM	GN5250 T= 0.6/0.8/1.0//1.2 MM	GN5260 T= 0.8/1.0 MM	GN5280 T= 0.9/1.1/1.3 MM
GN5310 T= 1.0 MM	GN 80YGTH T= 0.9/1.2/1.4 MM	GN80ACTH T=0.9/1.0/1.2/1.4 MM	GN 90TH T=1.0/1.2 MM
GN 0795 T=1.2/1.3/1.4/1.8 MM	GN 120TH T= 1.8 MM	GN2472 T= 1.9 MM	GN2477 T= 1.8 MM

圆管系列 ROUND TUBE SERIES >>>

GN2661 T=1.0 MM	GN2059 T=1.2 MM	GN150TH T=2.2 MM	GN180TH T=2.3MM
GN200TH T=2.5 MM	GN2855 T=0.8 MM	GN2884 T=1.5 MM	GN2271 T=1.5 MM
六边框系列 			方管吊件
GN 1231 T=0.6 MM	GN 1232 T=1.2 MM	T= MM	GN2772 T=2.0 MM
GN3721 T=1.9 MM	GN2862 T=1.8 MM		

子弹头系列 BULLET SERIES >>>

GN 1576ZDT T=0.9/1.1 MM	GN 100X40ZDT T=0.9/1.1 MM	GN 100X50ZDT T=1.0 MM
1:2 		
GN 120X30ZDT T=1.0/1.2 MM	GN 2238ZDT T=1.0/1.2 MM	GN 180X40ZDT T=1.6 MM
GN 120X50ZDT T=1.2 MM	GN 150X50ZDT T=1.1/1.3/1.5 MM	GN 0551 T=1.2 MM
GN 200X50ZDT T=2.0 MM	GN 250X60ZDT T=2.5 MM	GN 150X25ZDT T=1.5 MM
GN 0862 T=4.5 MM		GN 0863 T=4.5 MM

子弹头系列 BULLET SERIES >>>

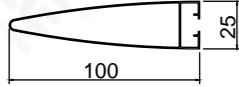
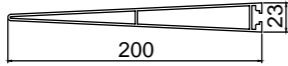
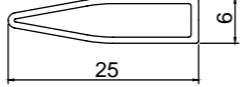
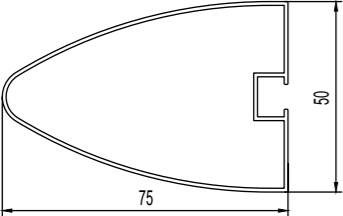
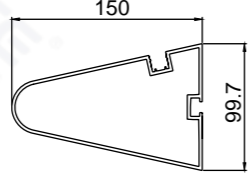
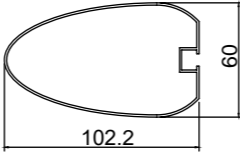
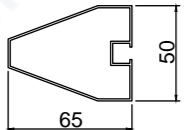
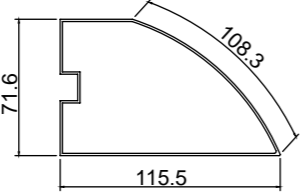
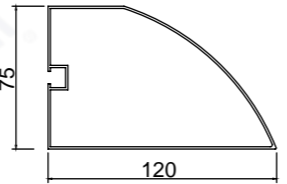
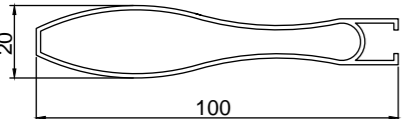
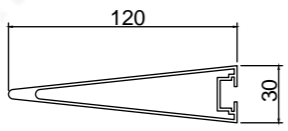
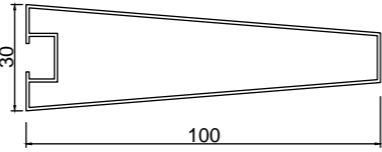
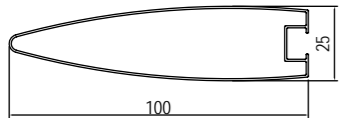
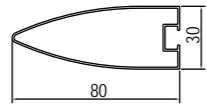
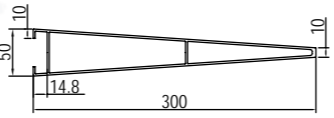
		
GN100X25X0.7TH T= 0.7 MM	GN2166 T= 2.0 MM	GN 0385 T=0.8 MM
		
GN 1500 T= 0.8 0.9 1.0 MM	GN2113 T= 2.5 MM	GN 1270 T= 1.2 MM
		
GN 0770 T= 1.1 MM	GN 1571 T= 1.2 MM	GN 1549 T= 1.2 MM
		
GN 1026 T= 1.2 MM	GNDG004 T= 1.5 MM	GN2953 T= 0.9 MM
		
GN100X25ZDT T= 0.7/0.9 MM	GN3607 T= 1.0 MM	GN3886 T=2.2 MM

滴水挂片系列 DRIP HANGING PIECE SERIES >>>

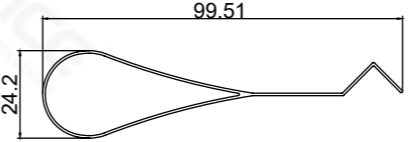
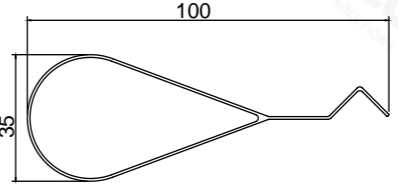
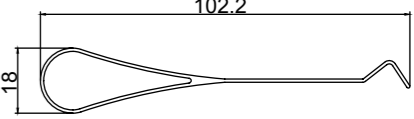
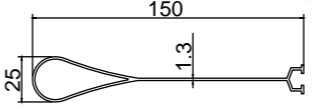
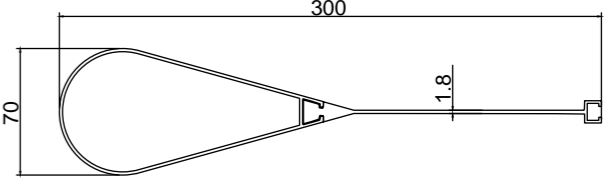
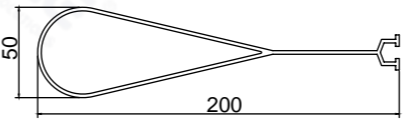
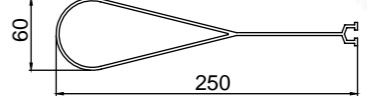
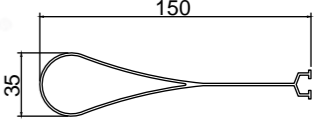
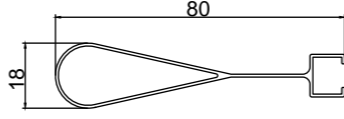
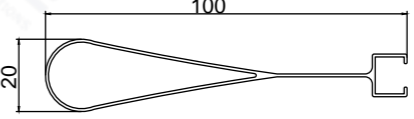
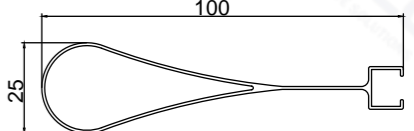
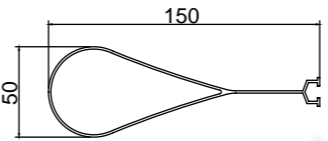
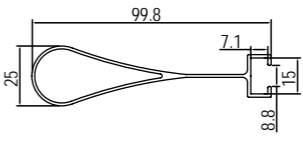
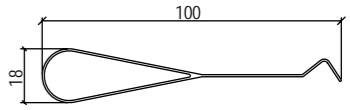
		
GN 0062 T=0.7/0.9/1.1 MM	GN 1717 T= 0.8 MM	GN F01 T=0.9/1.0/1.1/1.2MM
		
GN150X25DS T= 1.3 MM	GN 0702 配 GN 0703 T= 1.8 MM	
		
GN200X50DS T= 2.0 MM	GN250X60DS T= 2.5 MM	GN150X35DS T= 1.4 MM
		
GN80X18 滴水挂片 T= 0.8/0.9/1.1 MM	GN100X20 滴水挂片 T= 0.8/0.9/1.2 MM	GN100X25 滴水挂片 T= 0.8/0.9/1.2/1.4 MM
		
GN 150X50DS T= 1.4 MM	GN3684 T= 1.2 MM	GN3835 T= 0.7 MM



GN2439 配 GN2440 盖 	GN2085 配 GN2086 盖 	GN3639 配 GN1373 盖 	GN5025 配 GN2051 盖 护窗料 				
GN 2439 T=1.2 MM	GN 2440 T=1.0 MM	GN 2085 T=2.0 MM	GN 2086 T=2.0 MM	GN 3639 T=1.0 MM	GN 1373 T=0.9 MM	GN 5025 T=1.2 MM	GN 2051 T=1.2 MM
GN3800 配 GN3801 盖 护窗料 	护窗料 	护窗料 	护窗料 				
GN 3800 T=2.0 MM	GN 3801 T=1.0 MM	GN2053 T=1.0 MM	20B T=0.9 MM	GN 2051 T=1.2 MM	GN 2052 T=1.2 MM		
护窗料 	GN1454 配 GN1453 盖 	GN0832 配 GN0833 盖 	GN1195 配 GN1196 盖 				
76A T=1.2 MM	76B T=1.2 MM	GN 1454 T=1.5 MM	GN 1453 T=1.5 MM	GN 0832 T=1.5 MM	GN 0833 T=1.2 MM	GN 1195 T=0.8 MM	GN 1196 T=0.8 MM
GN5079 配 GN5082 盖 	GN1286 配 GN1285 盖 	GN0720 配 GN0721 盖 	GN2597 配 GN2598 盖 				
GN 5079 T=0.9 MM	GN 5082 T=1.1 MM	GN 1286 T=1.0 MM	GN 1285 T=1.0 MM	GN 0720 T=1.2 MM	GN 0721 T=1.2 MM	GN 2597 T=1.2 MM	GN 2598 T=0.8 MM
GN1301 配 GN1302 盖 	GN2846 配 GN2847 盖 	GN5070 配 GN5076 盖 	GN5071 配 GN5076 盖 				
GN 1301 T=1.2 MM	GN 1302 T=1.2 MM	GN2846 T=1.0 MM	GN2847 T=1.0 MM	GN 5070 T=0.9 MM	GN 5076 T=1.1 MM	GN 5071 T=0.9 MM	GN 5076 T=1.1 MM

GN3919 配 GN3920 盖 	GN2562 配 GN2563 盖 	GN5072 配 GN5076 盖 	GN5073 配 GN5076 盖 				
GN 3919 T=2.0 MM	GN 3920 T=2.0 MM	GN 2562 T=0.6 MM	GN 2563 T=0.8 MM	GN 5072 T=1.2 MM	GN 5076 T=1.1 MM	GN 5073 T=1.2 MM	GN 5076 T=1.1 MM
GN9801 配 9802 盖 	GN2865 配 GN1373 盖 	GN2814 配 GN2815 盖 	GN5074 配 GN5076 盖 				
GN 9801 T=1.0 MM	GN 9802 T=0.9 MM	GN2865 T=1.0 MM	GN1373 T=0.9 MM	GN2814 T=1.2 MM	GN2815 T=1.0 MM	GN 5074 T=1.0 MM	GN 5076 T=1.1 MM
GN5075 配 GN5076 盖 	GN1676 配 GN1677 盖 	GN5080 配 GN5082 盖 	GN5081 配 GN5082 盖 				
GN 5075 T=1.2 MM	GN 5076 T=1.1 MM	GN 1676 T=1.8 MM	GN 1677 T=1.1 MM	GN 5080 T=1.2 MM	GN 5082 T=1.1 MM	GN 5081 T=1.0 MM	GN 5082 T=1.1 MM
GN2823 配 GN2822 盖 	GN9811 配 GN0949 盖 	GN0948 配 GN0949 盖 	GN2821 配 GN2822 盖 				
GN2823 T=1.9 MM	GN2822 T=1.4 MM	GN 9811 T=1.0 MM	GN 0949 T=1.5 MM	GN 0948 T=1.2 MM	GN 0949 T=1.0 MM	GN2821 T=1.9 MM	GN2822 T=1.4 MM
GN2406 配 GN2407 盖 	GN2608 配 GN2609 盖 	GN2722 配 GN0949 盖 	GN3725 配 GN3726 盖 				
GN 2406 T=1.0/1.5 MM	GN 2407 T=1.6 MM	GN 2608 T=1.2 MM	GN 2609 T=1.2 MM	GN 2722 T=1.4 MM	GN 0949 T=1.0 MM	GN 3725 T=0.9 MM	GN 3726 T=0.9 MM



GN9813 配 GN0949 盖 	GN9814 配 GN0949 盖 	GN9815 配 GN0949 盖 	GN9817 配 GN0949 盖
GN 9813 T=1.0 MM	GN 0949 T=1.0 MM	GN 9814 T=1.2 MM	GN 0949 T=1.0 MM
GN2404 配 GN2403 盖 	GN2576 配 GN0949 盖 	GN9820 配 GN9820 盖 	GN9821 配 GN9820 盖
GN 2404 T=1.7 MM	GN 2403 T=1.7 MM	GN 2576 T=1.5 MM	GN 0949 T=1.0 MM
GN1284 配 GN1285 盖 	GN2686 配 GN2687 盖 	GN1404 配 GN1405 盖 	GN1296 配 GN1295 盖
GN 1284 T=1.0 MM	GN 1285 T=1.0 MM	GN 2686 T=1.8 MM	GN 2687 T=0.8 MM
GN9827 配 GN1285 盖 	GN1636 配 GN1405 盖 	GN1594 配 GN1405 盖 	GN1294 配 GN1295 盖
GN 9827 T=1.0 MM	GN1285 T=1.0 MM	GN 1636 T=1.0 MM	GN 1405 T=1.2 MM
GN2836 配 GN1285 盖 	GN2848 配 GN1285 盖 	GN3693 配 GN3694 盖 	GN9833 配 GN9836A 盖
GN2836 T=1.1 MM	GN1285 T=1.0 MM	GN2848 T=1.1 MM	GN1285 T=1.0 MM
GN 3693 T=2.0 MM	GN 3694 T=2.0 MM	GN 9833 T=1.2 MM	GN 9836A T=1.4 MM

GN9835 配 GN9836A 盖 	GN9837 配 GN9836A 盖 	GN9839 配 GN9836A 盖 	GN9841 配 GN9836A 盖
GN 9835 T=1.4 MM	GN 9836A T=1.4 MM	GN 9837 T=1.4 MM	GN 9836A T=1.4 MM
GN1469 配 GN1470 盖 	GN2582 配 GN2581 盖 	GN5083 配 GN5092 盖 	GN5084 配 GN5092 盖
GN 1469 T=1.2 MM	GN 1470 T=1.2 MM	GN 2582 T=2.0 MM	GN 2581 T=2.0 MM
GN5085 配 GN5093 盖 	GN3846 配 GN3831 盖 	GN2091 配 GN2092 盖 	GN2606 配 GN2607 盖
GN 5085 T=0.9 MM	GN 5093 T=1.0 MM	GN 3846 T=2.0 MM	GN 3831 T=1.0 MM
GN9845 配 1968 盖 	GN9846 配 1968 盖 	GN5086 配 GN5092 盖 	GN5087 配 GN5093 盖
GN 9845 T=1.0/1.2 MM	GN 1968 T=1.2 MM	GN 9846 T=1.0 MM	GN 1968 T=1.2 MM
GN5089 配 GN5093 盖 	GN1967 配 GN1968 盖 	GN3830 配 GN3831 盖 	GN5090 配 GN5092 盖
GN 5089 T=1.0 MM	GN 5093 T=1.0 MM	GN 1967 T=1.2 MM	GN 1968 T=1.2 MM
GN 3830 T=3.0 MM	GN 3831 T=1.0 MM	GN 5090 T=1.2 MM	GN 5092 T=1.3 MM



GN5091 配 GN5092 盖 	GN9855 配 GN9856 盖 	GN9857 配 GN9856 盖 	GN1757 配 GN1759 盖
GN 5091 T=1.2 MM	GN 5092 T=1.3 MM	GN 9855 T=1.8 MM	GN 9856 T=1.4 MM
GN1299 配 GN1300 盖 	GN2410 配 GN2411 盖 	GN0722 配 GN0723 盖 	GN5094 配 GN5104 盖
GN 1299 T=1.7 MM	GN 1300 T=1.2 MM	GN2410 T=1.0 MM	GN2411 T=1.0 MM
GN2080 配 2081 盖 	GN1259 配 GN1260 盖 	GN5095 配 GN5105 盖 	GN5096 配 GN5104 盖
GN2080 T=1.1 MM	GN2081 T=1.1 MM	GN 1259 T=2.4 MM	GN 1260 T=1.2 MM
GN3873 配 GN3874 盖 	GN3672 配 GN3673 盖 	GN2097 配 GN2098 盖 	GN5097 配 GN5105 盖
GN 3873 T=1.4 MM	GN 3874 T=1.4 MM	GN 2097 T=1.1 MM	GN 2098 T=1.1 MM
GN5099 配 GN5104 盖 	GN2037 配 GN2038 盖 	GN2037 配 GN2038 盖 	GN2568 配 GN2566 盖
GN5099 T=1.8 MM	GN5104 T=1.4 MM	GN2037 T=1.0 MM	GN2038 T=1.0 MM
GN2553 T=1.2 MM	GN 1669 T=1.5 MM	GN2568 T=1.9 MM	GN2566 T=1.2 MM

GN5100 配 GN5105 盖 	GN2110 配 2111 盖 	GN5101 配 GN5105 盖 	GN2567 配 2566 盖
GN5100 T=1.2 MM	GN5105 T=1.1 MM	GN2110 T=1.5/2.0 MM	GN2111 T=1.3 MM
GN5102 配 5104 盖 	GN2109 配 2111 盖 	GN5124 配 GN5121 盖 	GN5103 配 GN5104 盖
GN5102 T=1.4 MM	GN5104 T=1.4 MM	GN2109 T=1.5 MM	GN2111 T=1.3 MM
GN5106 配 GN5107 盖 	GN9877 配 GN9876 盖 	GN5124 配 GN5121 盖 	GN1416 配 GN1417 盖
GN 5106 T=1.5 MM	GN 5107 T=1.5 MM	GN 9877 T=1.0 MM	GN 9876 T=1.0 MM
GN9881 配 GN9880 盖 	GN1762 配 GN1763 盖 	GN9883 配 9884 盖 	GN9885 配 9884 盖
GN 9881 T=1.2 MM	GN 1417 T=1.3 MM	GN 1762 T=1.8 MM	GN 1763 T=1.8 MM
GN2234 T=1.8 MM	GN2233 T=1.5 MM	GN 1782 T=1.5 MM	GN 1783 T=1.5 MM
GN 9883 T=1.8 MM	GN 9884 T=1.8 MM	GN 9885 T=2.0 MM	GN 9884 T=1.8 MM
GN1782 配 GN1783 盖 	GN2653 配 GN2654 盖 	GN 2653 T=1.5 MM	GN 2654 T=2.0 MM
GN 1782 T=1.5 MM	GN 1783 T=1.5 MM	GN 2653 T=1.5 MM	GN 2654 T=2.0 MM



GN0718 配 0719 盖 	GN3782 配 GN3783 盖 	GN5109 配 GN5110 盖 	GN1153 配 GN1154 盖 				
GN 0718 T= 1.2 MM	GN 0719 T= 1.2 MM	GN 3782 T= 1.2 MM	GN 3783 T= 1.2 MM	GN 5109 T= 1.5 MM	GN 5110 T= 1.5 MM	GN 1153 T= 1.9 MM	GN 1154 T= 1.4 MM
GN9905 配 GN2654 盖 	GN9887 配 GN9889 盖 	GN1520 配 GN1519 盖 	GN2804 配 GN2805 盖 				
GN 9905 T= 2.0 MM	GN 2654 T= 1.4 MM	GN 9887 T= 1.4 MM	GN 9889 T= 1.4 MM	GN 1520 T= 2.0 MM	GN 1519 T= 1.4 MM	GN2804 T= 1.2 MM	GN2805 T= 1.4 MM
GN9901 配 GN9890 盖 			GN1039 配 GN1040 盖 				
GN 9901 T= 2.0 MM	GN 9890 T= 2.0 MM	GN 9891 T= 2.0 MM	GN 9890 T= 2.0 MM	GN 1039 T= 2.5 MM	GN 1040 T= 2.5 MM		
GN1545 配 GN1546 盖 							
GN 1545 T= 2.9 MM	GN 1546 T= 1.2 MM	GN 9887 T= 2.0 MM	GN 9890 T= 2.0 MM	GN 9897 T= 1.5 MM	GN 9898 T= 2.0 MM	GN 9895 T= 1.5 MM	GN 9898 T= 2.0 MM
GN1752 配 GN1753 盖 							
GN 1752 T= 3.0 MM	GN 1753 T= 1.5 MM	GN2169 T= 1.0 MM	GN2168 T= 1.0 MM	GN2225 T= 2.0 MM	GN2226 T= 1.2 MM	GN2692 T= 5.0 MM	GN2693 T= 2.0 MM

GN2126 配 GN2127 盖 	GN2664 配 GN2665 盖 	GN2389 配 GN2388 盖 	GN9835 配 GN9836A 盖 				
GN2126 T= 3.1 MM	GN2127 T= 2.0 MM	GN2664 T= 1.3 MM	GN2665 T= 1.3 MM	GN 2389 T= 1.2 MM	GN 2388 T= 1.2 MM	GN2345 T= 1.2 MM	GN2346 T= 2.0 MM
GN1765 T= 1.8 MM	GN1872 T= 2.0 MM	GN1870 T= 2.0 MM	GN1096 T= 1.0 MM				
GN 1097 T= 1.0 MM	GN 1098 T= 1.0 MM	GN 1099 T= 1.0 MM	GN 1100 T= 1.0 MM				
GN 1101 T= 1.0 MM	GN 1164 T= 1.0 MM	GN 1165 T= 1.5 MM	GN 1166 T= 1.5 MM				
GN 1167 T= 1.4 MM	GN 1767 T= 1.8 MM	GN 1168 T= 1.4 MM	GN 1169 T= 1.5 MM				

组合管系列 COMBINED PIPE SERIES >>>

GN 1162 T= 1.8 MM	GN 1163 T= 2.0 MM	GN2362 T= 2.0 MM	GN 1766 T= 1.8 MM
GN1871 T= 2.0 MM	GN 2870 T= 1.7 MM	GN 2871 T= 1.7 MM	GN 2872 盖 T= 1.8 MM



槽管系列 GROOVE PIPE SERIES >>>

GN3845 T= 1.3 MM	GN3872 T= 1.0 MM	GN 1624 T= 1.7 MM	GN 2090 T= 1.2 MM
GN2321 T= 1.1 MM	GN 1020 T= 1.2 MM	GN2435 T= 0.9 MM	GN 1019 T= 1.2/1.4MM
GN3939 T= 1.0 MM	GN3561 T= 1.2 MM	GN2619 T= 1.4 MM	GN3854 T= 1.0 MM
GN 0958 T= 2.0 MM	GN2868 T= 1.4 MM	GN 1712 T= 1.2 MM	GN2185 T= 1.2 MM
GN3587 T= 1.2 MM	GN30X30TH T= 1.0MM	GN0799 T= 1.5MM	GN 1420 T= 0.9 MM



GN 1501 T= 1.2 MM	GN 2813 T=1.2 MM	GN 2290 T= 1.0 MM	GN 3045 T= 1.2 MM
GN 2785 T=1.2 MM	GN 1947 T= 1.2 MM	GN 2016 T= 1.5 MM	GN 2120 T= 1.0 MM
GN 3426 T= 0.8 MM	GN 2817 T=1.5 MM	GN 2015 T= 1.5 MM	GN 1805 T= 1.4 MM
GN 2147 T= 1.1 MM	GN 2515 T=1.2 MM	GN 2516 T=1.5 MM	GN 2961 T= 1.5 MM
GN 2416 T= 1.3 MM	GN 2417 T= 1.3 MM	GN 2570 T=1.5 MM	GN 3573 T= 1.2 MM

GN 2571 T=1.5 MM	GN 3574 T= 1.2 MM	GN 1093 T= 1.5 MM	GN 2777 T=0.9 M
GN 2442 T=1.4 MM	GN 2829 T=1.2 MM	GN 3770 T= 2.9 MM	GN 0823 T= 1.5 MM
GN 3942 T= 1.5 MM	GN 0856 T= 1.4 MM	GN 2734 T=1.0 MM	GN 0917 T= 3.0 MM
GN 1754 T= 1.4 MM	GN 1837 T= 1.2 MM	GN 0658 T= 1.0 MM	GN 1957 T= 2.0 MM
GN 0846 T= 1.2 MM	GN 1018 T= 1.2 MM	GN 1022 T=1.2/1.4 MM	GN 2119 T=1.4 MM



GN2451 T=2.0 MM	GN2160 T=1.4 MM	GN2159 T=1.4 MM	GN3080 T=1.8 MM
GN2320 T=1.5 MM	GN2835 T=1.4 MM	GN1024 T=1.5 MM	GN1787 T=1.4 MM
GN1057 T=1.4 MM	GN2517 T=1.5 MM	GN3558 T=2.2 MM	GN1608 T=2.0 MM
GN2453 T=2.0 MM	GN2222 T=1.7 MM	GN1338 T=3.0 MM	GN1445 T=2.4 MM
GN1973 T=2.0 MM	GN1999 T=1.5 MM	GN2184 T=1.2 MM	GN2779 T=1.0 MM

GN1975 T=1.1 MM	GN2243 T=2.0 MM	GN1180 T=1.2 MM	GN2704 T=1.2 MM
GN2167 T=1.5 MM	GN0747 T=1.2 MM	GN1734 T=1.4 MM	GN1340 T=1.5 MM
GN0839 T=2.0 MM	GN2391 T=2.0 MM	GN3533 T=1.5 MM	GN3850 T=1.4 MM
GN2380 T=1.5 MM	GN2265 T=1.0 MM	GN2264 T=1.0 MM	GN2778 T=1.0 MM
GN2375 T=2.0MM	GN2789 T=1.2 MM	GN1946 T=1.2 MM	GN2434 T=0.9 MM



GN2303 T= 1.7 MM	GN3779 T= 1.4 MM	GN3941 T= 1.0 MM	GN 1349 T= 1.2 MM
GN 1480 T= 1.2 MM	GN2118 T= 1.4 MM	GN 0821 T= 1.5 MM	GN2707 T=1.5 MM
GN2733 T=1.2 MM	GN2796 T=1.1 MM	GN 1148 T= 1.4 MM	GN2705 T=1.0 MM
GN2157 T= 1.4MM	GN2158 T= 1.4 MM	GN3534 T= 1.5 MM	GN2405 T= 1.8 MM
GN2519 T=1.5 MM	GN2716-JC7001 T= 3.0 MM	GN3758 T= 2.0 MM	GN3302 T= 1.9 MM

GN2706 T=1.8 MM	GN2198 T= 2.5 MM	GN2911 T= 2.4 MM	GN 1092 T= 1.6 MM
GN2330 T= 2.0 MM	GN3851 T= 1.4 MM	GN2830 T=1.2 MM	GN3073 T= 1.0 MM
GN 0919 T= 3.0 MM	GN 1964 T= 1.2 MM	GN 1996 T= 1.2 MM	GN2520 T=1.2 MM
GN2667 T=1.2 MM	GN2454 T=2.0 MM	GN3852 T= 1.4 MM	GN3420 T= 2.0 MM
GN2522 T=1.4 MM	GN3312 T= 1.3 MM	GN2521 T= 1.5 MM	GN2565 T=1.8 MM



GN2261 T=2.0 MM	GN2787 T=1.8 MM	GN 1023 T= 1.5 MM	GN 1620 T= 1.8 MM
GN 1863 T= 2.0 MM	GN2260 T= 2.0 MM	GN2969 T= 2.2 MM	GN2259 T= 2.6 MM
GN3791 T= 2.8 MM	GN2329 T=1.4MM	GN 0918 T= 3.0 MM	GN 1761 T= 1.3 MM
GN 1377 T= 1.8 MM	GN2412 T= 1.5 MM	GN2594 T=1.4 MM	GN2523 T= 1.4 MM
GN2708 T= 1.8 MM	GN3449 T= 1.9 MM	GN2450 T=2.0 MM	GN2452 T=2.8 MM

GN 0792 T=2.0 MM	GN 0791 T= 2.0 MM	GN 0967 T= 2.0 MM	GN2379 T= 1.5 MM
GN1905 T= 1.9 MM	GN2906 T= 2.0 MM	GN3771 T= 1.9 MM	GN2895 T= 1.8 MM
GN2336 T= 1.9 MM	GN2327 T= 1.8 MM	GN3955 T= 1.5 MM	GN2115 T= 2.0 MM
GN 1337 T= 3.0 MM	JJ-GN1515 T= 3.0 MM	GN2583 T= 3.0 MM	GN2524 T= 1.8 MM
GN3567 T= 1.9 MM	GN3963 T= 2.0 MM	GN5013 T= 2.0 MM	GN3940 T= 1.5 MM



GN5012 T= 2.0 MM	GN2643 T= 2.3 MM	GN 0867 T= 1.4 MM	GN 1424 T= 2.0 MM
GN 1266 T= 2.0 MM	GN9902 T= 2.2 MM	GN9903 T= 2.5 MM	GN3907 T= 2.5 MM
GN3703 T= 1.8 MM	GN5014 T= 2.0 MM	GN3535 T= 1.5 MM	GN 1186 T= 1.1 MM
GN 0974 T= 1.6 MM	GN2195 T= 2.0 MM	GN 1187 T= 1.1 MM	GN 1731 T= 2.0 MM
GN3909 T= 1.8 MM	GN2849 T= 3.0 MM	GN 1504 T= 1.8 MM	GN3547 T= 1.8 MM

GN3546 T= 1.8 MM	GN2850 T= 3.0 MM	GN 1644 T= 3.5 MM	GN 1643 T= 3.5 MM
GN3560 T= 2.5 MM	GN3624 T= 2.5 MM	GN3625 T= 2.5MM	GN3559 T= 2.5 MM
GN2851 T= 1.2 MM	GN3855 T= 1.8 MM	GN3702 T= 1.1 MM	GN 2300 T= 2.0 MM
GN 2334 T= 1.5 MM	GN 2540 T= 1.8 MM	GN 1564 T= 1.5 MM	GN 3059 T= 1.0 MM
GN 1820 T= 1.8 MM	GN 1331 T= 1.2 MM	GN3217 T= 1.5 MM	GN3637 T= 1.3 MM

槽管系列 GROOVE PIPE SERIES >>>

GN3690 T= 1.0 MM	GN3218 T= 1.5 MM	GN3219 T= 1.5 MM	GN3352 T= 1.0/1.2MM
GN3309 T= 1.8 MM	GN5530 T= 1.2 MM	GN5529 T= 1.2 MM	GN3298 T= 2.0 MM
GN2869 T= 2.0 MM	GN5069 T= 1.5 MM	GN5128 T= 1.2 MM	GN3220 T= MM
GN3221 T= 1.6 MM			

SCOPE OF APPLICATION 适用范围

适用于机场、火车站、地铁、候机厅、运动场馆、办公楼、餐厅、酒吧、超市、商场、餐厅、酒店大厅等的内外墙

It is applicable to the internal and external walls of airports, railway stations, subway stations, waiting halls, sports venues, offices, office buildings, restaurants, bars, supermarkets, shopping malls, restaurants, hotel halls, etc

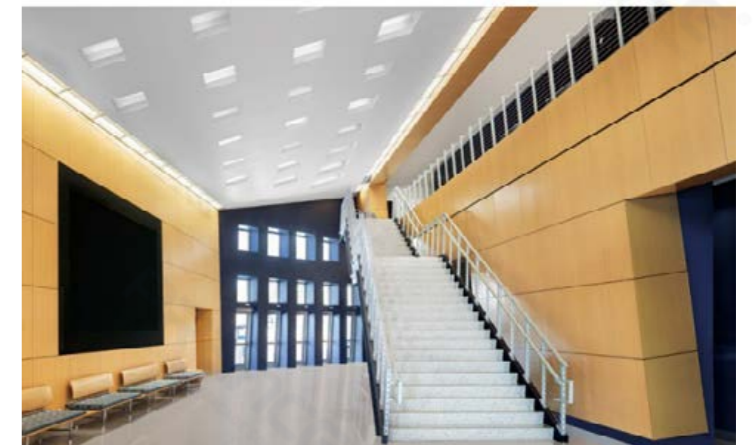

经典系列 CLASSIC SERIES >>>

GN 1175 T= 1.9 MM	GN 1176 T= 1.9 MM	500301 T= 1.2 MM	500201 T= 1.2 MM
500101 T= 1.2 MM	GN 1226 T=1.8 MM	500401 T= 1.0 MM	500501 T= 1.0 MM



GN 0932 T= 1.4 MM	GN 1440 T= 2.5 MM	GN 1038 T= 1.8 MM	GN 1171 T= 2.0 MM
GN 1267 T= 2.0 MM	GN 1143 T= 2.0 MM	GN 0968 T= 2.0 MM	GN 0933 T= 2.0 MM
GN 1397 T= 3.0 MM	JJ-GN1743 T= 2.0 MM	GN 0966 T= 1.9 MM	GN 1152 T= 1.6 MM
GN 1191 T= 2.0 MM	GN 1140 T= 2.0 MM	GN0793 T= 2.5 MM	GN 0889 T= 1.4/1.6/2.0 MM
GN 2044 T= 1.4 MM	GN 1352 T= 2.5 MM	GN 1972 T= 2.0 MM	GN 0962 T= 1.8 MM

GN 0725 T= 1.2 MM	GN 0774 T= 2.0 MM	GN 0805 T= 2.0 MM	GN 0809 T= 2.1 MM
GN 1581 T= 3.0 MM	GN 1733 T= 1.8 MM	GN2205 T= 3.5 MM	JJ-GN1513 T= 2.5 MM
GN2201 T= 2.9 MM	GN2187 T= 2.0 MM	GN 1091 T= 1.4 MM	GN 1739 T= 2.0 2.9 MM
GN2730 T= 2.3 MM	GN2220 T= 3.0 MM	GN2506 T= 1.5 MM	MH-GN0783 T= 3.0 MM
GN7002 T= 2.0 MM	GN7003 T= 2.0 MM	GN7004 T= 2.0 MM	GN7005 T= 2.0 MM





JJ-GN1086 T= 1.3 MM	JJ-GN1064 T= 1.5 MM	JJ-GN1065 T= 1.5 MM	JJ-GN1069 T= 1.5 MM
GN2711 T=1.5 MM	GN2337 T= 5.0 MM	GN2331 T= 2.0 MM	GN2720 T=1.5 MM
GN2721 T=1.5 MM	GN 2047 T= 2.0 MM	GN2204 T= 3.5 MM	GN2600 T=2.0 MM
GN2308 T= 2.7 MM	GN 1494 T= 1.7 MM	GN2651 T= 1.0 MM	GN2718 T= 2.0 MM
GN2709 T= 2.9 MM	GN 0773 T= 1.5 MM	GN 1003 T= 1.5 MM	GN 1892 T= 2.3 MM

GN3614 T= 1.2 MM	GN3915 T= 0.8 MM	GN2944 T= 3.0 MM	GN3904 T= 2.0 MM
GN3222 T= 1.8 MM	GN3362 T= 2.0 MM	GN3363 T= 2.0 MM	GN3695 T=2.0 MM
GN3484 T= 3.0 MM	GN3685 T= 2.0 MM	GN3575 T= 0.9 MM	GN3839 T=1.8 MM
GN5005 T= 1.5 MM	GN 0806 T=2.0MM	GN2573 T=1.4 MM	GN2574 T=2.0 MM
GN2659 T=2.0 MM	GN2735 T= 0.6 MM	GN2754 T= 1.0 MM	GN 1941 T= 1.4 MM

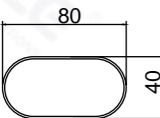
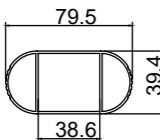
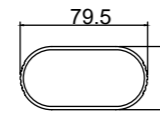
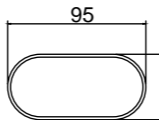
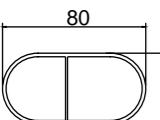
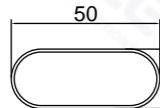
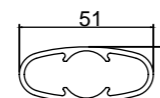
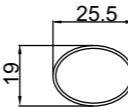
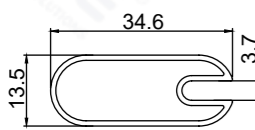
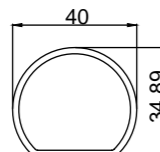
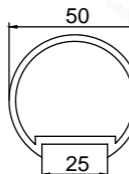
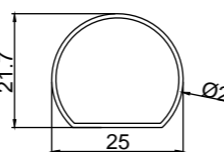
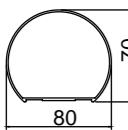
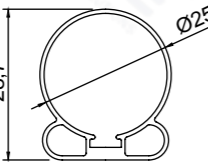
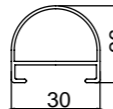
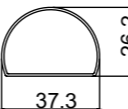
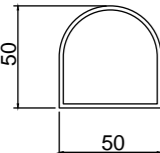
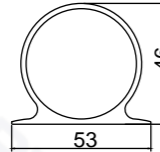
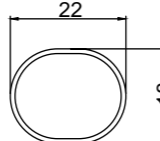
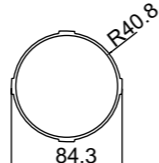

			
GN 1032 T= 1.5/1.8/2.0 MM	GN 1082 T=1.5 MM	GN 1083 T=2.0 MM	GN 1659 T= 2.0 MM
			
GN 2572 T=2.0 MM	GN 1159 T= 1.0 MM	GN 1139 T= 1.9 MM	GN 2569 T= 0.9 MM
			
GN 0764 T= 1.0 MM	GN 2644 T= 1.8 MM	GN 1611 T= 2.5 MM	GN 1237 T= 0.8 MM
			
GN 1794 T= 1.4 MM	GN 1868 T= 0.8 MM	GN 1395 T= 1.2 MM	XQ-ZH04-GN1245 T= 1.0 MM
			
GN 2717 T= 2.0 MM	GN 0873 T= 2.0 MM	GN 0726 T= 0.9 MM	GN0761 T= 2.0 MM

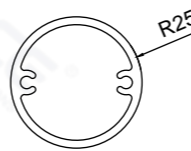
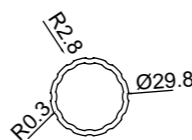
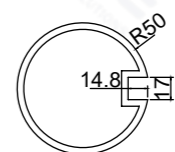
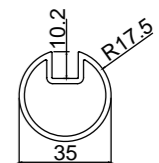
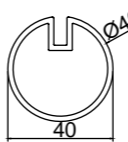
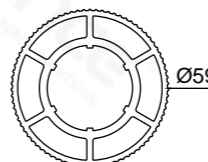
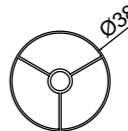
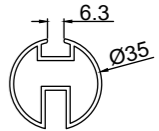
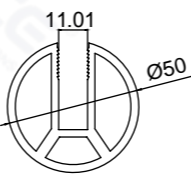
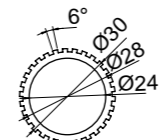
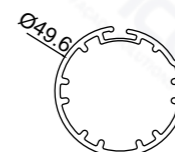
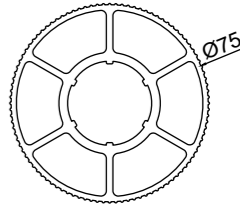
铝艺系列 ALUMINUM ART SERIES >>>

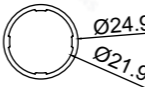
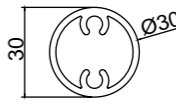
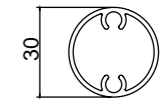
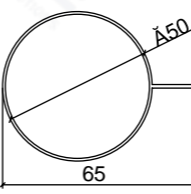
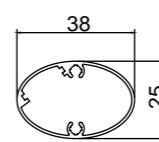
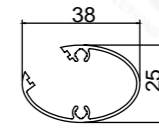
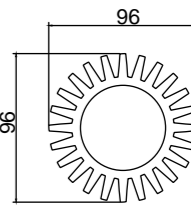
			
GN 0835 T= 2.5 MM	GN1079 T=1.9 MM	GN 1213 T=5.0 MM	GN 0765 T=2.0 MM
			
GN 0766 T=2.0 MM	GN 1380 T= MM	GN 1512 T= 0.7 MM	GN 1369 T= 1.5 MM
			
GN1965 T=3.0MM	GN 1623 T= MM	GN-Y036 T= 1.0 MM	GN 1381 T= MM
			
GN 1379 T= MM	GN 1076 T=1.5 MM	GN2253 T=2.1 MM	GN2274 T=1.5 MM
			
GN 1937 T=0.9 MM	GN 0882 T=0.9 MM	GN 0883 T=1.0 MM	GN 1116 T= MM



GN 1318 T=1.5 MM	GN 1971 T=0.8 MM	GN 1490 T=0.7 MM	GN 1407 T=2.0 MM
GN 1718 T=0.9 MM	GN 1085 T=2.3 MM	A-11090 T=2.8 MM	GN-Hi016 T=3.0 MM
GN 1072 T=3.0 MM	GN-Hi015 T=2.1 MM	GN 1277 T=1.5/2.0 MM	GN 1066 T=2.0 MM
GN 1061 T=2.7 MM	GN-Hi010 T=2.8 MM	GN 1428 T=1.4 MM	GN 1192 T=2.0 MM
GN 1009 T=1.2 MM	GN 0727 T=2.0 MM	GN 1364 T=4.0 MM	GN 1124 T=2.4 MM

铝艺系列 ALUMINUM ART SERIES >>>

JJ-GN1071 T= 3.0 MM	JJ-GN1275 T= 2.7 MM	JJ-GN1276 T= 3.0 MM	GN 1135 T= 1.5 MM
GN 1136 T= 1.5 MM	GN2354 T= 1.2 MM	GN2355 T= 1.2 MM	GN 1363 T= 4.3 MM
GN 1354 T= 2.2 MM	GN 1185 T= 1.1 MM	GN-Hi001 T= 2.4 MM	GN2079 T= 1.4 MM
GN 2068 T= 1.4 MM	GN 1062 T=2.4 MM	GN 1854 T= 1.7 MM	GN 1148 T=1.4 MM
GN 1997 T=1.2 MM	GN2121 T= 1.2 MM	GN3059 T= 1.0 MM	GN 1014 T=0.8 MM



GN 1149 T=1.0 MM	GN 1077 T=1.0 MM	GN 1078 T=1.5 MM	GN 1080 T= 1.5 MM
GN2372 T= 2.5 MM	GN 1151 T= 1.2 MM	GN 1081 T= 1.5 MM	GN 1411 T= 1.3 MM
GN 1073 T=2.0 MM	GN 1150 T= 1.5 MM	GN 1278 T= 3.0 MM	GN 0859 T= 3.3 MM
GN 1068 T= 2.9 MM	GN 1193 T= 1.5 MM	GN 0713 T= 1.2 MM	GN 1174 T=0.7 MM
GN 1304 T= MM	GN 1303 T= MM	GN 1084 T= 1.3 MM	GN 1279 T= 2.0 MM

铝艺系列 ALUMINUM ART SERIES >>>

GN Hi005 T= 1.5 MM	GN 1324 T= 1.8 MM	GN 1060 水槽 T= 2.0 MM	GN 0864 T= 3.9 MM

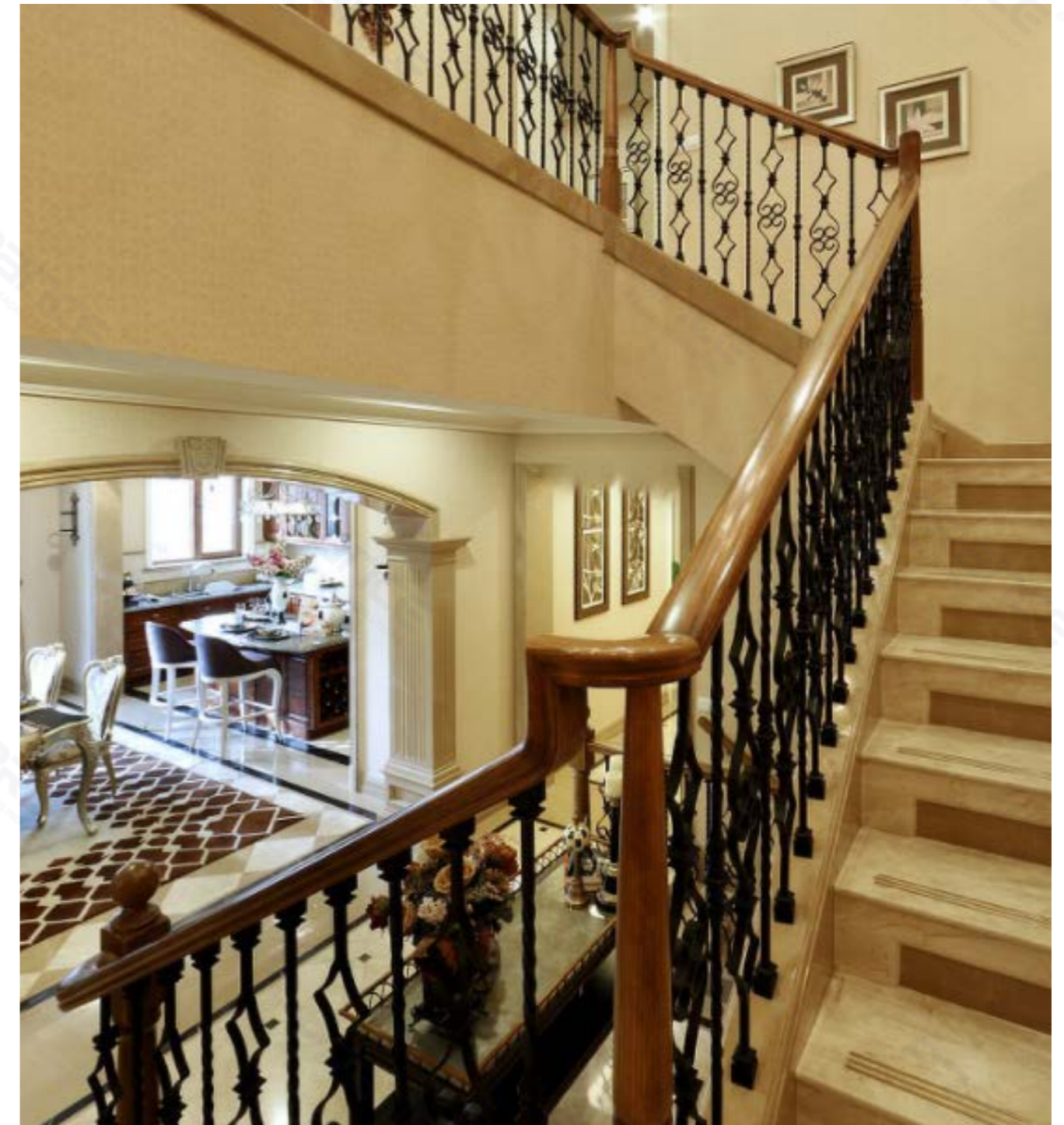



GN 0084 T=0.9 MM	GN 0092 T=1.2 MM	GN 0161 T=1.1 MM	GN 0162 T=0.9 MM
GN 0209 T=0.7 MM	GN 0474 双钩 T=0.7 MM	GN 0983 T=0.9 MM	GN 0269 T=0.9 MM
GN 1037 T= 0.8 MM	75x1.2 百叶片 T= 0.7/1.0/1.2 MM	GN 1170 单钩 T= 0.8 MM	GN1290 双钩 T= 2.2 MM
GN 1439 双钩 T=1.2 MM	GN 2049 单钩 T= 1.8 MM	GN3246 双钩 T= 2.2MM	GN3515 单钩 T= 1.0MM
GN 0420 T= 0.4 MM	GN 0498 T= 0.4 MM	ZY-018 T=0.8 MM	GN 1132 T=0.9 MM

GN 1548 T=0.4 MM	GN 1441 T=0.4 MM	GN2878 T=1.2 MM	GN 0882 T= 0.9 MM
GN 1329 T=1.0 MM	GN 1464 T=1.0 MM	GN 1463 T=1.1 MM	GN 1462 T=1.2 MM
GN 1221 T= 1.7 MM	GN 6608 T= 1.7 MM	GN 1137 T=2.0 MM	GN 6018 T= 1.7 MM
GN 6098 T= 2.0 MM	GN 6628 T= 2.5 MM	GN 6618 T= 1.7 MM	GN 1265 T= 2.2 MM
GN2701 T= 2.0 MM	GN 6708 T=2.3 MM	GN 6698 T=2.3 MM	GN 6638 T= 2.5 MM



FC-BY086 T=3.0 MM	GN 6658 T=2.5 MM	GN 6668 T= 2.5 MM	GN5018 T= 2.5MM
GN 0977 T= 1.4 MM	GN 0539 T= 2.0 MM	GN2173 T= 1.0 MM	GN2296 T= 0.9 MM
GN 0965 T= 2.8 MM	GN2596 T= 3.0 MM	GN 0667 T= 1.1 MM	GN1138 T=3.0 MM
GN 1593 T=1.2 MM	GN 1616 T=1.5 MM	GN2688 T=1.4 MM	GN 0845 T=2.0 MM
GN 0405 T=1.3 MM	GN 0406 T= 1.8 MM	GN2585 T=1.2 MM	GN2794 T=1.4 MM

GN2586 T=1.2 MM	GN7008 T=1.4 MM	GN7009 T=1.4 MM	GN 1523 T=1.5 MM
GN2662 T=1.4 MM	GN 1264 T= 2.0 MM	GN2641 T=1.2 MM	GN2642 T= 1.2 MM
GN3353 T= 1.2MM	GN3530 T= 1.4MM	GN3820 T= 3.0MM	GN3584 T=2.4MM



地脚线系列 ANCHOR WIRE SERIES >>>

GN2752 T= 0.9 MM	GN2753 T= 0.9 MM	GN 2020 T= 1.2 MM	GN 2023 T= 0.9 MM
GN 2029 T= 0.8 MM	GN 2022 T= 1.0 MM	GN 2021 T= 1.2 MM	GN 2033 T= 0.8 MM
GN 2024 T= 1.2 MM	GN 2048 T= 1.0 MM	GN 2025 T= 0.8 MM	GN 2031 T= 0.7 MM
GN 2505 T= 0.7 MM	GN2652 T= 1.2 MM	GN 3008 T= 0.9 / 1.1MM	GN2089 T= 0.9 MM
GN2759 T= 1.0 MM	GN 2028 T= 0.9 MM	GN 2032 T= 0.9 MM	GN2620 T= 2.0 MM

地脚线系列 ANCHOR WIRE SERIES >>>

GN 2026 T= 0.8 MM	GN 2027 T= 1.2 MM	GN2689 T= 2.0 MM	





35X16 加强筋 T= 0.9/1.0/1.2/1.4/1.8/2.0/2.4/3.0/4.0/ MM	37.5x20 加强筋 T= 1.2 MM	37X18 加强筋 T= 1.0 MM	38X17 加强筋 T= 1.0 1.2 MM
GN1597 T=1.2 MM	40X17 加强筋 T= 1.5 MM	45.2X20 加强筋 T=1.7 MM	54X24 加强筋 T= 2.8 MM
GN1596 T=1.4 MM	GN1612 T= 1.1 MM	35X22 加强筋 T= 1.5 MM	34X20 加强筋 T=1.0 MM
40X20 加强筋 T=3.9 MM	GN2162 T= 1.0 MM	GN2164 T= 1.0 MM	40X17 加强筋 T= 1.5 MM
GN2229 T= 1.0 MM	GN0802 T= 1.0 MM	GN2128 T= 1.3 MM	GN2102 T= 1.7 MM

GN1567 T= 0.8 MM	GN2793 T=0.8 MM	GN2490 T= 1.5 MM	GN0803 T= 1.8 MM
GN10X10C 槽 T=0.8 MM	GN2199 T= 1.0 MM	GN1896 T=1.2 MM	10X18U 槽 T= 1.6 MM
GN0931 T=0.9 MM	GN1845 T= 1.0 MM	GN2614 T= 1.0 MM	GN2613 T=1.0 MM
12X12U 槽 T= 1.0 MM	GN0560 T= 1.2 MM	GN1956 T= 0.8 MM	10*15U 槽 T= 1.0 MM
15X15U 槽 T= 1.2 MM	GN2418 T= 0.8 MM	GN2209 T= 0.8 MM	GN2328 T= 0.8 MM



GN2105 T= 0.8 MM	GN1988 T= 0.8 MM	GN2649 T= 1.5 MM	SD-041 T= 1.3 MM
20X9X0.8U 槽 T=0.8 MM	GN0801 T= 1.0 MM	GN1255 T= 2.0 MM	GN1406 T= 1.0 MM
20X20U 槽 T= 1.4 / 2.0 MM	JJ-GN1817 T= 3.0 MM	GN0618 T= 2.3 MM	GN1217 T= 2.0 MM
GN1320 T= 0.8 MM	GN0605 T= 1.0 MM	GN2647 T= 3.0 MM	26X20U 槽 T= 3.0 MM
GN2703 T= 2.0 MM	GN1409 T= 0.9 MM	GN2487 T= 1.2 MM	GN1987 T= 0.8 MM

GN2489 T= 0.9 MM	30X30U 槽 T= 1.5 MM	GN2096 T= 2.5 MM	GN2474 T= 1.0 MM
GN1585 T= MM	32X38U 槽 T= 1.7 MM	GN2471 T= 1.0 MM	34X20U 槽 T= 1.9 MM
GN2742 T= 1.8 MM	GN1388 T= 2.3 MM	GN1875 T= 3.0 MM	37X19U 槽 T= 2.0 MM
GN0978 T= 2.3 MM	GN2504 T= 2.5 MM	38X20U 槽 T= 1.8 MM	GN2587 T= 2.5 MM
GN0886 T= 1.4 MM	GN1804 T= 2.5 MM	40X40U 槽 T= 3.0 MM	GN1547 T= 4.9 MM



GN1598 T= 1.5 MM	GN2618 T= 1.8 MM	48X24U 槽 T= 1.8 MM	GN2615 T= 0.8 MM
GN2478 T= 1.0 MM	GN1989 T= 0.8 MM	GN2248 T= 2.7 MM	GN2539 T= 5.0 MM
53X30U 槽 T= 3.0 MM	GN0979 T= 2.9 MM	GN1662 T= 1.8 MM	GN1243 T= 3.0 MM
63X30U 槽 T= 3.0 MM	GN0980 T= 2.9 MM	GN2124 T= 6.4 MM	GN2545 T= 1.0 MM
GN1430 T= 10 MM	GN1934 T= 1.9 MM	GN1830 T= 1.2 MM	GN1461 T= 2.0 MM

GN2123 T= 6.4 MM	GN1566 T= 2.0 MM	GN1746 T= 2.5 MM	GN1565 T= 2.0 MM
GN0447 T= 8.0 MM	GN2816 T= 3.0 MM	GN2831 T= 2.0 MM	GN2858 T= 3.0 MM
GN3060-37X15 加强筋 T= 1.9 MM	40X21.9 加强筋 T= / MM	GN3640 T= 2.0MM	GN3902 T= 1.2MM
38X18.5UC T= 2.4MM	29X20 加强筋 T= 1.0 MM	GN3671 加强筋 T= MM	GN3650 T= 1.2 MM
GN3355 T= 1.0 MM	30X5U T= 0.7 MM	GN2922 T= 2.4 MM	GN3773 T= 2.5 MM

加强筋系列 STIFFENER SERIES >>>

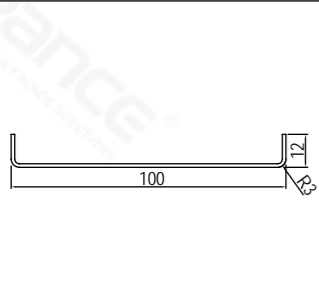
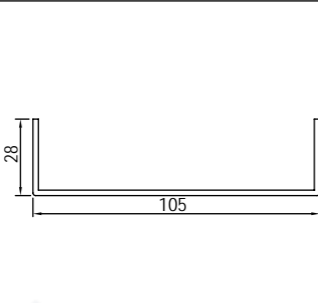
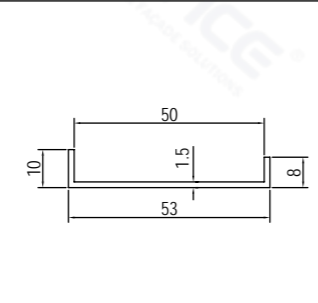
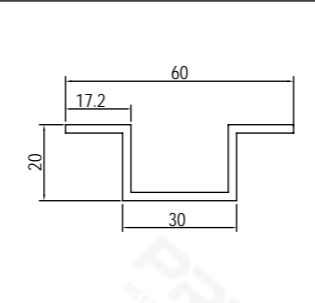
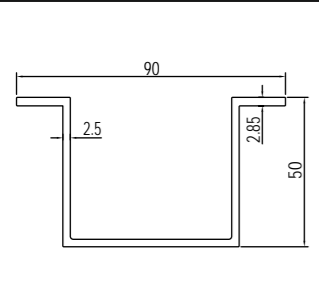
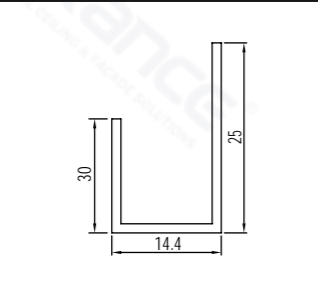
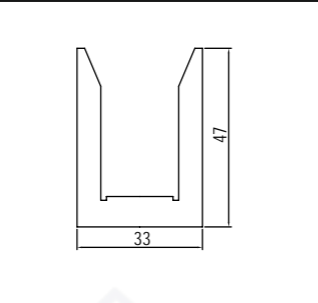
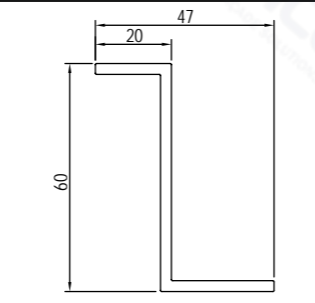
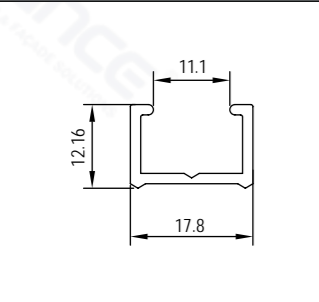
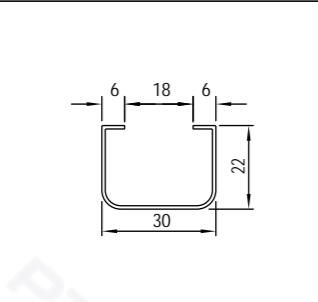
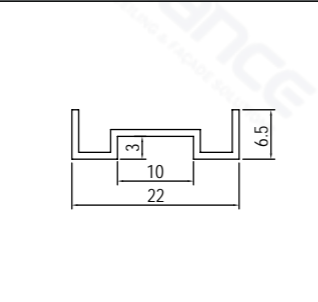
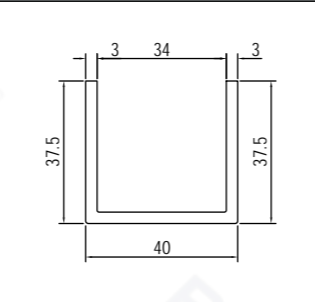
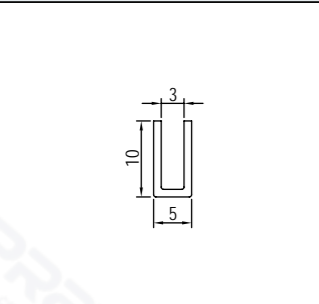
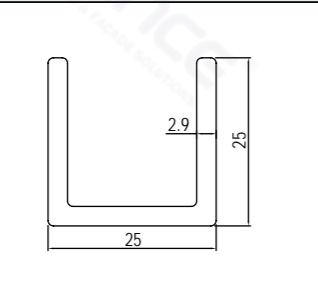
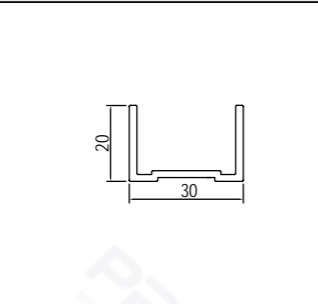
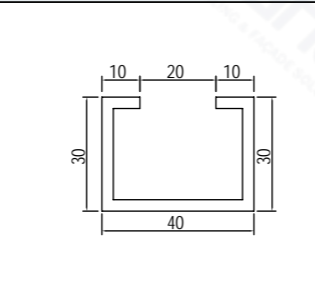
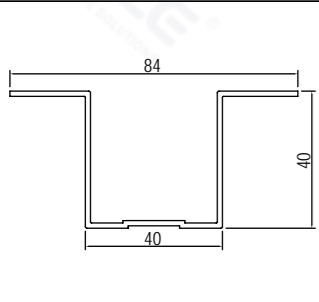
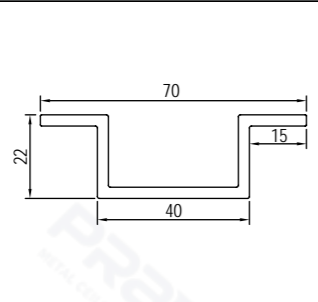
			
GN3290 T= 1.3MM	GN3295 T= 2.0 MM	GN3586 T= 1.5 MM	GN3327 T= 2.2 MM
			
GN3539 T= 2.5 MM	GN3557 T= 1.2 MM	GN2896 T= 6.3 MM	GN3865 T= 2.9 MM
			
GN3760 T= 1.5 MM	GN3751 T= 0.9 MM	GN3520 T= 1.0 MM	GN3692 T= 3.0 MM
			
GN3792 T= 1.0 MM	25X25U 加强筋 T= 2.9 MM	30X20X2.0 加强筋 T= 2.0 MM	GN3990-40X30 加强筋 T= 3.0 MM
			
GN3967-84X40 T= 1.5 MM	GN5040 T= 2.9 MM		

方管规格 SQUARE TUBE SPECIFICATION

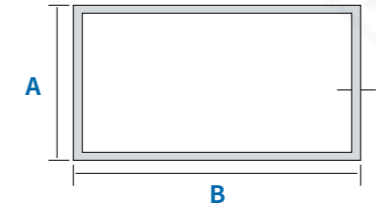

SPECIFICATION(MM) H * W 规格 (MM) 高 * 宽	THICKNESS 厚度	SPECIFICATION(MM) H * W 规格 (MM) 高 * 宽	THICKNESS 厚度	SPECIFICATION(MM) H * W 规格 (MM) 高 * 宽	THICKNESS 厚度		
10*10	1.00	25*10	1.00	30*30	0.80		
	1.20		1.20		1.00		
12*8	1.00		1.50		1.20		
12*12	1.80	25*15	1.00		1.50		
15*7	0.50		1.20		1.80		
	1.00		1.50		2.00		
15*10	1.20	25*20	0.90	32*32	2.50		
	2.00		1.00		3.00		
			1.20		1.00		
15*15	1.20	25*25	1.60		35*15	1.20	
	1.50		0.50			1.50	
	2.00		0.70			0.90	
16*16	1.20		30*8	1.00		35.2*22.3	3.00
18*8	1.00			0.80			2.00
19*8.5	0.7			1.20			1.00
19*19	0.80	30*10		1.50	38*20		1.00
	1.00			1.80			0.60
	1.20			2.00			0.80
20*10	2.00		30*15	2.50		38*25	1.00
	0.80			3.00			1.20
	1.00			1.00			1.50
20*15	1.20	30*20		0.90	38*38		1.80
	1.50			1.00			2.00
	1.70			1.20			1.50
20*16	1.20		40*10	0.80		40*15	0.80
20*17	2.00			0.90			1.00
20B (带螺丝管)	1.00			1.00			1.20
20*20	0.60	30*25		1.50	40*20		1.50
	0.80			1.80			0.60
	1.00			2.00			0.80
	1.20		3.00	1.00			
	1.50		1.50	1.20			
	1.80		2.00	1.50			
2.00	2.50	1.00	2.00				
2.50	3.00	1.20	0.60				
3.00	1.00	1.50	0.80				
22*10	1.00	30*30	0.60		1.00		
22*22	1.20						

方管规格 SQUARE TUBE SPECIFICATION



SPECIFICATION(MM) H * W 规格 (MM) 高 * 宽	THICKNESS 厚度	
40*20	1.20	
	1.50	
	1.80	
	2.00	
	2.50	
	3.00	
40*25	0.70	
	0.90	
	1.20	
	1.50	
	1.60	
	2.00	
40*27	2.00	
40*28	2.00	
40*30	0.60	
	0.80	
	1.00	
	1.20	
	1.50	
	1.80	
	2.00	
	2.50	
	3.00	
40*40	0.60	
	0.80	
	1.00	
	1.20	
	1.50	
	1.80	
	2.00	
	2.50	
	3.00	
	4.00	
	45*20	2.00
	45*25	0.80
0.90		
1.00		
1.20		
45*45	1.00	
	1.20	
	1.50	
	1.80	
48*29	2.00	
50*5	0.90	
50*7	1.00	
50*10	1.00	
	1.20	
	2.50	
	3.00	

SPECIFICATION(MM) H * W 规格 (MM) 高 * 宽	THICKNESS 厚度
50*15	1.00
	1.20
	1.50
50*20	0.70
	0.80
	0.90
	1.00
	1.20
	1.50
	1.80
50*25	0.60
	0.80
	0.90
	1.00
	1.20
	1.50
	1.80
	2.00
	2.50
	3.00
50*30	0.70
	0.80
	0.90
	1.00
	1.20
	1.50
	1.80
	2.00
	2.50
	3.00
50*35	1.00
50*40	0.70
	0.80
	0.90
	1.00
	1.20
	1.50
	2.00
50*50	0.60
	0.80
	0.90
	1.00
	1.20
	2.00

SPECIFICATION(MM) H * W 规格 (MM) 高 * 宽	THICKNESS 厚度
50*50	2.50
	3.00
	4.00
	5.00
	6.00
54*27	1.50
55*30	2.00
60*10	1.00
	1.20
	2.00
60*15	1.00
	1.80
60*20	0.70
	0.80
	0.90
	1.00
	1.20
	1.50
	1.80
60*25	0.80
	0.90
	1.20
	1.50
	1.80
	2.00
60*30	0.70
	0.80
	0.90
	1.20
	1.50
	1.80
	2.00
	2.50
	3.00
	3.00
60*35	2.00
	2.00
	2.50
	3.00
60*38	6.50
60*40	0.60
	0.80
	0.90
	1.00
	1.20
	1.50
	1.80
	2.00
3.00	
4.00	

SPECIFICATION(MM) H * W 规格 (MM) 高 * 宽	THICKNESS 厚度	
60*40	5.00	
60*50	1.00	
	1.20	
	1.50	
	2.00	
	3.00	
60*60	0.80	
	1.00	
	1.20	
	1.50	
	2.00	
	2.50	
	2.80	
	4.00	
	70*10	1.00
	70*12	1.00
70*15	1.00	
70*20	0.80	
	1.00	
	1.20	
	1.50	
70*23.7	1.20	
70*25	2.00	
70*30	0.70	
	0.80	
	1.00	
	1.20	
	1.50	
	1.60	
	2.00	
	2.50	
	3.00	
	3.00	
70*30 圆角 (GN0875)	2.00	
70*40	0.80	
	1.00	
	1.20	
	1.50	
	1.80	
	2.00	
	2.50	
	3.00	
70*50	0.80	
	1.00	
	1.20	
	1.50	
	1.80	
	2.00	
	2.50	

SPECIFICATION(MM) H * W 规格 (MM) 高 * 宽	THICKNESS 厚度
70*50	3.00
70*60	6.50
	3.00
70*70	1.50
	1.80
	3.00
	6.00
74*24	0.70
75*25	1.00
	1.50
	1.80
75*30	1.00
	1.20
	1.50
	2.50
	3.00
75*35	0.60
	1.00
	1.20
75*45	1.80
75*50	0.90
	1.00
	1.20
	1.50
	2.50
75*70	1.50
75*75	1.80
76*23 (圆角)	5.50
76*20	1.20
76*25	0.80
	1.00
	1.20
	1.50
	1.80
	2.00
	2.00
76*38	6.50
76*44	0.60
	0.80
	1.00
	1.20
	1.50
	1.80
	2.00
	2.50
76*76	1.20
	1.50
	1.80
	2.00
	3.00

SPECIFICATION(MM) H * W 规格 (MM) 高 * 宽	THICKNESS 厚度
76*76	6.50
80*10	1.00
	1.20
	2.00
80*13	1.20
80*15	1.50
80*20	0.80
	0.90
	1.00
	1.20
	1.50
	2.00
80*25	0.80
	1.00
	1.20
	1.50
	2.00
	2.50
80*30	0.80
	1.00
	1.20
	1.50
	1.80
	2.00
80*40	0.70
	0.80
	0.90
	1.00
	1.20
	1.50
	1.80
80*44	2.00
	0.70
	0.80
	0.90
	1.00
80*50	1.20
	1.50
	1.80
	2.00
	2.50
	3.00

方管规格 SQUARE TUBE SPECIFICATION



SPECIFICATION(MM) H * W 规格 (MM) 高 * 宽	THICKNESS 厚度
80*50	4.00
80*60	0.80
	1.00
	1.20
	1.50
	1.80
	2.00
	2.50
	3.00
3.90	
80*80	0.80
	1.00
	1.20
	1.50
	1.80
	2.00
	2.50
	3.00
4.00	
5.00	
85*18	1.20
86*26	1.00
90*20	0.80
	1.00
	1.20
	1.60
90*30	2.00
	0.80
	0.90
	1.00
90*40	1.20
	2.00
	0.80
	1.00
	1.20
	1.50
90*50	1.80
	2.00
	2.50
	3.00
	3.00
	3.50
	4.00
	4.00
91.3*22.2	1.00
95*20	1.50
100*10	1.00
	1.50

SPECIFICATION(MM) H * W 规格 (MM) 高 * 宽	THICKNESS 厚度
100*10	2.00
100*15	0.80
	1.00
	1.20
	1.50
	2.00
	2.00
100*20	0.70
	0.80
	0.80
	1.00
	1.20
	1.50
	1.80
	2.00
100*25	2.50
	3.00
	3.80
	0.70
	0.80
	0.90
	1.00
	1.20
100*30	1.50
	2.00
	2.00
	2.50
	3.00
	5.00
	0.70
	0.80
100*40	0.90
	1.00
	1.20
	1.50
	1.80
	2.00
	2.50
	3.00
100*44	3.50
	4.00
	0.80
	0.90

SPECIFICATION(MM) H * W 规格 (MM) 高 * 宽	THICKNESS 厚度
100*44	1.50
	2.00
	2.50
	3.10
	3.10
100*46	1.50
100*50	0.70
	0.80
	0.90
	1.00
	1.20
	1.50
	1.80
	2.00
	2.50
	3.00
4.00	
101.5*51	1.10
100*60	0.80
	0.90
	1.00
	1.20
	1.50
	1.80
	2.00
100*65	2.50
	1.50
	2.30
100*70	1.00
	1.30
	1.50
	1.80
100*75	2.00
	1.20
	1.50
	2.00
	3.00
100*80	1.00
	1.20
	1.50
	1.80
	2.00
	2.50
	2.80
	3.00
100*90	2.00
100*100	1.00
	1.20
	1.50
	2.00

SPECIFICATION(MM) H * W 规格 (MM) 高 * 宽	THICKNESS 厚度
100*100	2.30
	2.50
	3.00
	3.80
	4.00
	5.00
	6.00
	6.00
110*30	1.20
110*40	2.50
	1.50
110*50	1.50
110*60	1.80
110*65	2.50
110*110	2.00
	2.80
116*76 (GN0941)	2.00
120*10	1.20
120*15	1.20
120*20	0.80
	0.90
	1.00
	1.20
	1.50
	1.80
	2.00
	2.50
120*25	3.00
	0.80
	0.90
	1.00
	1.20
	1.50
	1.80
	2.00
120*30	2.50
	0.80
	0.90
	1.00
	1.20
	1.50
	1.80
	2.00
2.50	
3.00	
120*38	2.00
120*40	0.80
	0.90
	1.00
	1.20
	1.50
	1.60
	1.80
	2.00
	2.00
	2.50

SPECIFICATION(MM) H * W 规格 (MM) 高 * 宽	THICKNESS 厚度
120*40	3.00
	4.00
120*50	0.80
	0.90
	1.00
	1.20
	1.50
	1.80
	2.00
	2.50
120*60	3.00
	1.00
	1.20
	1.50
	1.80
	2.00
	2.00
	2.50
120*65	3.00
120*70	4.00
	2.00
	3.00
120*80	1.20
	1.30
	1.50
	1.80
	2.00
	2.50
	3.00
	4.00
120*100	1.20
	1.50
	1.80
	2.00
	2.50
	3.00
	3.00
	4.00
120*120	1.50
	2.00
	2.50
	2.80
	3.00
125*50	3.00
125*65	2.00
130*30	1.50
	1.80
130*40	2.00
	1.50
130*50	1.80
130*60	1.50

SPECIFICATION(MM) H * W 规格 (MM) 高 * 宽	THICKNESS 厚度
130*65	2.00
130*100	3.00
130*130	1.50
	2.00
	2.50
	3.00
135*135	2.00
	3.00
136*50	2.00
140*20	1.00
140*25	1.30
140*30	1.50
140*40	1.50
140*50	1.80
	2.40
140*60	1.50
140*65	2.00
140*70	2.00
140*80	1.50
	1.80
140*100	2.00
140*120	2.00
140*140	2.00
	2.50
	3.00
150*10	1.20
150*15	1.20
150*20	0.80
	0.90
	1.00
	1.20
	1.50
	1.80
	2.00
	2.50
150*25	3.00
	0.80
	0.90
	1.00
	1.20
150*30	1.50
	1.80
	2.00
	2.50
	3.00
	3.00

方管规格 SQUARE TUBE SPECIFICATION



SPECIFICATION(MM) H * W 规格 (MM) 高 * 宽	THICKNESS 厚度	SPECIFICATION(MM) H * W 规格 (MM) 高 * 宽	THICKNESS 厚度	SPECIFICATION(MM) H * W 规格 (MM) 高 * 宽	THICKNESS 厚度	SPECIFICATION(MM) H * W 规格 (MM) 高 * 宽	THICKNESS 厚度	SPECIFICATION(MM) H * W 规格 (MM) 高 * 宽	THICKNESS 厚度	SPECIFICATION(MM) H * W 规格 (MM) 高 * 宽	THICKNESS 厚度						
150*30	3.00	150*100	1.80	180*40	1.50	200*25	2.00	200*80	2.80	250*25	1.5 带筋						
150*35	2.0		2.00		1.60		2.50		3.00		3.00	3.00	4.00	2.20			
150*40	0.80		2.50		2.00		2.00		200*30		1.3 带筋	1.50	200*90	2.00	250*30	1.3 带筋	
	0.90		2.80		2.50		1.30				1.50	1.50		2.50		2.00	1.6 带筋
	1.00		3.00		3.00		1.50				1.60	1.80		1.80		3.00	2.00
	1.20		3.50	3.50	1.80	2.00	2.30	2.50		1.90	2.20	3.00		3.00			
	1.50		4.00	4.00	2.00	2.50	3.00	3.00		2.00	2.20	4.00		4.00			
	1.80		4.50	4.50	2.50	3.80	4.00	4.00		2.50	2.20	1.6 带筋		2.20			
	2.00		5.00	5.00	3.00	4.00	4.00	4.00		2.80	2.50	2.50		3.00			
2.50	5.00		5.00	4.00	4.00	4.00	4.00	3.00	2.20	3.00	4.00						
3.00	5.00	5.00	4.00	4.00	4.00	4.00	3.00	2.50	3.00	4.00							
150*50	0.90	150*120	3.00	180*50	1.30	200*40	1.3 带筋	200*100	1.50	250*40	1.6 带筋						
	1.00		4.00		1.50		1.50		1.50		1.60	1.80	1.80	2.00	2.20		
	1.20		4.00		1.50		1.80		1.80		2.00	2.00	2.00	2.00	3.00	3.00	
	1.50		4.00		1.80		2.00		2.00		2.50	2.50	2.50	2.50	3.00	4.00	
	1.80		4.00		2.00		2.30		2.50		3.00	3.00	3.00	3.00	4.00	4.00	
	2.00	4.00	150*150	2.50	180*60		2.00		1.3 带筋		2.80	3.00	3.00	3.00	4.00		
	2.50	4.00		1.50			2.80		2.80		1.50	1.50	3.00	3.50	4.00	4.00	
	3.00	4.00		1.80			3.00		3.00		2.00	1.80	3.50	4.00	4.00	4.00	
	4.00	4.00		2.00			3.00		3.00		2.50	2.00	4.00	5.00	5.00	6.00	
	0.90	4.00		2.30			2.50		3.00		3.00	2.50	6.00	6.00	6.00	6.00	
150*60	1.00	160*20	1.50	180*75	2.00	200*50	3.00	200*120	1.60	250*50	1.3 带筋						
	1.20		1.80		2.00		2.00		2.00		1.80	2.00	2.00	2.00	1.8 带筋		
	1.30		1.80		2.00		2.50		2.50		2.00	2.00	2.50	2.50	2.00	2.00	
	1.50		1.80		2.50		2.50		3.00		2.50	2.50	2.50	3.00	2.50	2.50	
	1.60		1.80		3.00		3.00		3.00		3.00	3.00	3.00	3.00	3.00	3.00	
	1.80	1.80	3.50	3.50	4.00		4.00		4.00		4.00	4.00	4.00	4.00			
	2.00	1.80	4.00	4.00	4.80		4.80		4.00		4.00	4.00	4.00	4.00			
	2.50	1.80	4.00	4.00	1.80		1.80		1.3 带筋		1.50	2.50	2.50	2.50			
	3.00	1.80	5.00	5.00	2.00		2.00		1.50		1.80	3.00	3.00	3.00			
	4.00	1.80	6.00	6.00	2.50		2.50		1.80		2.00	3.00	3.00	3.00			
150*65	0.90	160*25	1.90	180*100	2.50	200*60	2.30	200*150	1.80	250*60	1.4 带筋						
	1.00		2.00		3.00		3.00		3.00		3.00	3.00	3.00	3.00	3.00	3.00	
	1.20		2.00		2.00		4.00		4.00		2.30	2.30	2.50	2.50	2.50	2.50	
	1.30		2.00		2.50		4.00		4.00		2.50	2.50	2.50	2.50	2.50	2.50	
	1.50		2.00		2.50		4.00		4.00		2.80	2.80	2.50	2.50	2.50	2.50	
	1.60	2.00	2.50	4.00	4.00		3.00		3.00		2.60	2.60	2.60	2.60			
	1.80	2.00	2.50	4.00	4.00		3.00		3.00		2.80	2.80	2.80	2.80			
	2.00	2.00	2.50	4.00	4.00		4.00		4.00		3.00	3.00	3.00	3.00			
	2.50	2.00	2.50	4.00	4.00		5.00		5.00		3.00	3.00	3.00	3.00			
	3.00	2.00	2.50	4.00	4.00		5.00		5.00		4.00	4.00	4.00	4.00			
150*70	2.00	160*30	2.50	180*120	2.50	200*70	1.4 带筋	200*180	2.50	250*70	1.5 带筋						
	2.80		2.50		2.00		2.00		2.00		2.00	2.00	2.00	2.00	2.00		
	1.50		2.50		2.50		2.50		2.50		2.50	2.50	2.50	2.50	2.50	2.50	
	1.60		2.50		2.50		2.50		2.50		2.50	2.50	2.50	2.50	2.50	2.50	
	2.00		2.50		2.50		2.50		2.50		2.50	2.50	2.50	2.50	2.50	2.50	
150*75	2.50	160*40	1.50	180*180	2.50	200*80	2.00	200*200	2.80	250*80	2.80						
	3.00		2.00		2.00		2.00		2.00		2.00	2.00	2.00	2.00	2.00		
	4.00		2.00		2.00		2.00		2.00		2.00	2.00	2.00	2.00	2.00	2.00	
	0.90		2.00		2.00		2.00		2.00		2.00	2.00	2.00	2.00	2.00	2.00	
	1.00		2.00		2.00		2.00		2.00		2.00	2.00	2.00	2.00	2.00	2.00	
150*80	1.20	160*50	2.00	190*50	2.00	200*90	1.60	210*210	3.00	250*90	3.00						
	1.30		2.00		2.00		2.00		2.00		2.00	2.00	2.00	2.00	2.00	2.00	
	1.50		2.00		2.00		2.00		2.00		2.00	2.00	2.00	2.00	2.00	2.00	
	1.80		2.00		2.00		2.00		2.00		2.00	2.00	2.00	2.00	2.00	2.00	
	2.00		2.00		2.00		2.00		2.00		2.00	2.00	2.00	2.00	2.00	2.00	
150*100	2.50	160*60	2.00	190*76	2.00	200*100	1.60	225*50	4.00	250*100	4.00						
	3.00		2.00		2.00		2.00		2.00		2.00	2.00	2.00	2.00	2.00	2.00	
	4.00		2.00		2.00		2.00		2.00		2.00	2.00	2.00	2.00	2.00	2.00	
	0.90		2.00		2.00		2.00		2.00		2.00	2.00	2.00	2.00	2.00	2.00	
	1.00		2.00		2.00		2.00		2.00		2.00	2.00	2.00	2.00	2.00	2.00	
150*100	1.30	160*70	2.00	192*175	2.00	200*110	1.60	230*50	4.00	250*110	4.00						
	1.50		2.00		2.00		2.00		2.00		2.00	2.00	2.00	2.00	2.00	2.00	
	1.80		2.00		2.00		2.00		2.00		2.00	2.00	2.00	2.00	2.00	2.00	
	2.00		2.00		2.00		2.00		2.00		2.00	2.00	2.00	2.00	2.00	2.00	
	2.50		2.00		2.00		2.00		2.00		2.00	2.00	2.00	2.00	2.00	2.00	
150*100	3.00	160*80	2.50	198*44	2.50	200*120	1.3 带筋	240*30	1.5 带筋	250*120	1.5 带筋						
	4.00		2.50		2.50		2.50		2.50		2.50	2.50	2.50	2.50	2.50	2.50	
	0.90		2.50		2.50		2.50		2.50		2.50	2.50	2.50	2.50	2.50	2.50	
	1.00		2.50		2.50		2.50		2.50		2.50	2.50	2.50	2.50	2.50	2.50	
	1.20		2.50		2.50		2.50		2.50		2.50	2.50	2.50	2.50	2.50	2.50	
150*100	1.30	160*100	1.80	200*10	1.8 带筋	200*130	1.3 带筋	240*80	1.5 带筋	250*130	1.5 带筋						
	1.50		2.00		2.00		2.00		2.00		2.00	2.00	2.00	2.00	2.00	2.00	
	1.80		2.00		2.00		2.00		2.00		2.00	2.00	2.00	2.00	2.00	2.00	
	2.00		2.00		2.00		2.00		2.00		2.00	2.00	2.00	2.00	2.00	2.00	
	2.50		2.00		2.00		2.00		2.00		2.00	2.00	2.00	2.00	2.00	2.00	
150*100	3.00	160*160	3.00	200*15	2.00	200*140	1.3 带筋	250*20	1.5 带筋	250*140	1.5 带筋						
	4.00		3.00		3.00		3.00		3.00		3.00	3.00	3.00	3.00	3.00	3.00	
	0.90		3.00		3.00		3.00		3.00		3.00	3.00	3.00	3.00	3.00	3.00	
	1.00		3.00		3.00		3.00		3.00		3.00	3.00	3.00	3.00	3.00	3.00	
	1.20		3.00		3.00		3.00		3.00		3.00	3.00	3.00	3.00	3.00	3.00	
150*100	1.30	180*20	1.50	200*20	1.50	200*150	1.4 带筋	250*30	1.6 带筋	250*150	1.6 带筋						
	1.50		2.00		2.00		2.00		2.00		2.00	2.00	2.00	2.00	2.00	2.00	
	1.80		2.00		2.00		2.00		2.00		2.00	2.00	2.00	2.00	2.00	2.00	
	2.00		2.00		2.00		2.00		2.00		2.00	2.00	2.00	2.00	2.00	2.00	
	2.50		2.00		2.00		2.00		2.00		2.00	2.00	2.00	2.00	2.00	2.00	
150*100	3.00	180*25	2.00	200*25	1.3 带筋	200*160	1.3 带筋	250*40	1.6 带筋	250*160	1.6 带筋						
	4.00		2.00		2.00		2.00		2.00		2.00	2.00	2.00	2.00	2.00	2.00	
	0.90		2.00		2.00		2.00		2.00		2.00	2.00	2.00	2.00	2.00	2.00	
	1.00		2.00		2.00		2.00		2.00		2.00	2.00	2.00	2.00	2.00	2.00	
	1.20		2.00		2.00		2.00		2.00		2.00	2.00	2.00	2.00	2.00	2.00	
150*100	1.30	180*30	2.00	200*30	1.50	200*170	1.3 带筋	250*50	1.6 带筋	250*170	1.6 带筋						
	1.50		2.00		2.00		2.00		2.00		2.00	2.00	2.00	2.00	2.00	2.00	
	1.80		2.00		2.00		2.00		2.00		2.00	2.00	2.00	2.00	2.00	2.00	
	2.00		2.00		2.00		2.00		2.00		2.00	2.00	2.00	2.00	2.00	2.00	
	2.50		2.00		2.00		2.00		2.00		2.00	2.00	2.00	2.00	2.00	2.00	
150*100	3.00	180*38	1.4 带筋	200*40	1.50	200*180	1.4 带筋	250*60	1.4 带筋	250*180	1.4 带筋						
	4.00		1.4 带筋		1.4 带筋		1.4 带筋		1.4 带筋		1.4 带筋	1.4 带筋	1.4 带筋	1.4 带筋	1.4 带筋	1.4 带筋	
	0.90		1.4 带筋		1.4 带筋		1.4 带筋		1.4 带筋		1.4 带筋	1.4 带筋	1.4 带筋	1.4 带筋	1.4 带筋	1.4 带筋	
	1.00		1.4 带筋		1.4 带筋		1.4 带筋		1.4 带筋		1.4 带筋	1.4 带筋	1.4 带筋	1.4 带筋	1.4 带筋	1.4 带筋	
	1.20		1.4 带筋		1.4 带筋		1.4 带筋		1.4 带筋		1.4 带筋	1.4 带筋	1.4 带筋	1.4 带筋	1.4 带筋	1.4 带筋	

方管规格 SQUARE TUBE SPECIFICATION

SPECIFICATION(MM) H * W 规格 (MM) 高 * 宽	THICKNESS 厚度
250*150	3.50
	4.00
	5.00
250*200	3.00
	3.50
	4.00
250*250	4.70
	5.00
300*20	2.2 带筋
300*25	1.8 带筋
	2.50
	3.00
300*30	1.8 带筋
	2.0 带筋
	2.50
	3.00
300*40	1.8 带筋
	2.50
	3.00
300*50	1.8 带筋
	2.0 带筋
	2.20
	2.50
	3.10
	3.50
	4.00
5.00	
300*60	2.0 带筋
	2.50
	3.00
300*70	2.50
	3.00
	3.00
300*75	2.50
	3.00
	3.00
300*80	2.0 带筋
	2.50
	3.00
	4.00
300*90	5.00
	3.00
	3.50
300*100	2.00
	2.0 带筋
	2.30
	2.50
	2.80
	3.00
	3.50
	4.00
5.00	

SPECIFICATION(MM) H * W 规格 (MM) 高 * 宽	THICKNESS 厚度
300*120	2.70
	3.00
	3.50
	4.00
300*150	2.50
	2.80
	3.00
	3.50
	4.00
300*160	5.00
	3.50
	4.00
300*180	3.50
300*200	3.50
	4.00
300*300	4.50
350*40	2.5 带筋
350*50	2.2 带筋
	3.00
350*60	3.50
	4.00
350*80	3.50
350*100	3.50
	4.00
400*50	3.00
400*100	3.50
	4.60
400*130	12.50
400*200	4.00
500*70	4.00
	5.50
500*100	5.00
500*200	6.00
600*200	5.00
700*100	5.00

圆管规格 ROUND TUBE SPECIFICATIONS

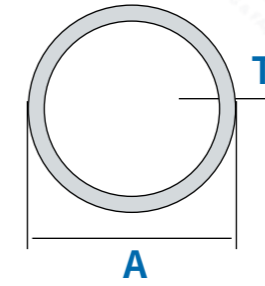

PROFILE NUMBER 型材编号	OUTER DIAMETER 外径 (MM)	THICKNESS (MM) 壁厚
9.7YG	9.7	1.0
GN1552	12	2.0
GN0207	12.5	1.2
15YG	15	1.0
		1.2
		2.0
16YG	16	1.0
		1.2
GN1553	18	4.5
19YG	19	1.0
		1.2
		1.5
20YG	20	1.0
		1.2
		1.5
		2.0
21YG	21	1.0
		1.2
		1.4
		2.0
22YG	22	1.2
23.7YG	23.7	1.2
GN1076	24.9	1.5
25YG	25	0.8
		1.0
		1.2
		1.5
		2.0
		2.5
28YG	28	3.0
		1.2
		1.5
29.4YG	29.4	1.5
29.8YG	29.8	2.0
30YG	30	0.8
		1.0
		1.2
		1.5
		1.8
		2.0
		3.0
		4.0
5.0		
31YG	31	1.5

PROFILE NUMBER 型材编号	OUTER DIAMETER 外径 (MM)	THICKNESS (MM) 壁厚
GN0534	36	1.8
38YG	38	1.0
		1.2
40YG	40	0.8
		1.0
		1.2
		1.5
		1.8
		2.0
41YG	41	3.0
		4.0
		5.0
46YG	46	2.5
48YG	48	1.5
50YG	50	1.0
		0.8
		1.0
		1.2
		1.5
		2.0
50.8YG	50.8	2.5
		2.8
		3.0
60YG	60	3.8
		1.8
		3.0
		1.0
70YG	70	1.2
		1.5
		2.0
GN0796	75	3.0
76YG	76	4.0
80YG	80	1.0
		1.2
		1.5
		2.0
		2.5
83YG	83	3.0
		6.8



圆管规格 ROUND TUBE SPECIFICATIONS

PROFILE NUMBER 型材编号	OUTER DIAMETER 外径 (MM)	THICKNESS (MM) 壁厚
90YG	90	2.0
100YG	100	1.2
		1.5
		1.8
		2.0
		3.0
110YG	110	2.0
120YG	120	1.5
		2.0
		3.0
150YG	150	1.6
		1.8
		2.0
		2.5
		3.0
		4.0
160YG	160	2.0
		3.0
		4.0
180YG	180	2.0
		2.5
		3.0
191YG	191	8.5
200YG	200	2.0
		2.5
		3.0
		4.0
220YG	220	3.0
		3.5
		4.0
230YG	230	5.0
240YG	240	5.0
250YG	250	5.0
260YG	260	5.0
270YG	270	5.0
280YG	280	5.0
290YG	290	5.0
300YG	300	5.0
310YG	310	5.0
320YG	320	10.0
		20.0
		40.0
		50.0
		85.0

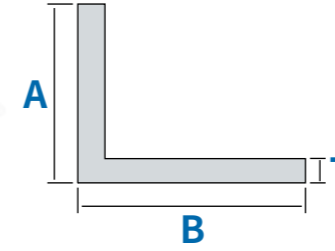
角铝规格 ANGLE ALUMINUM SPECIFICATION



PROFILE NUMBER 型材编号	OUTER DIAMETER 外径 (MM)	THICKNESS (MM) 壁厚
GN3117	6*6	1.0
GN0677	6.5*6.5	2.0
	8*8	2.0
		3.0
GN2806	10x7	0.6
		0.8
GN0538	10*10	1.0
		1.5
		2.0
		3.0
GN0920	10*15	1.0
GN1360	12*12	1.2
		1.2
	14*12	1.2
		1.5
		1.4
	18*12	1.8
		2.0
		1.8
	19*19	1.8
		0.8
		2.0
	20*15	2.0
		1.0
		1.6
		2.0
		2.5
	20*20	3.0
		4.0
		1.8
	25*6	1.2
		1.3
	25*15	1.5
		1.5
		2.0
	25*20	1.5
		2.0
	25*25	3.0
		2.0
GN0638	25*25 (圆角)	2.0
	25*15	1.8
		2.0
		3.2
		2.8
	25*28	3.0
		0.5
GN0246	30*10	0.5
	30*15	3.0
		1.0
		1.2

PROFILE NUMBER 型材编号	OUTER DIAMETER 外径 (MM)	THICKNESS (MM) 壁厚
	30*20	1.5
		2.0
		2.5
		3.0
	30*25	3.0
		0.8
GN1183	30*30	1.0
		1.5
		2.0
	30*33	2.8
		1.0
GN0515	30*33	1.0
SL-GN0550	32*32	3.0
	37X37	2.5
		3.0
		3.0
GN0395(39.6 花角)		8.9
		1.8
	40*20	3.0
		1.5
SL-GN0134	40*30	2.0
	40*40	2.0
		3.0
		4.0
		6.0
500801		9.0
		2.9
	45*20 角	2.0
		3.0
GN0005	45*25	3.0
		3.0
	48*16.5	1.2
		2.0
	50*30	3.0
		2.0
	50*50	2.5
		3.0
		4.0
		5.0
		3.0
	52*25	2.8
		2.0
	60*26	3.0
		4.0
		8.0
		8.0

角铝规格 ANGLE ALUMINUM SPECIFICATION

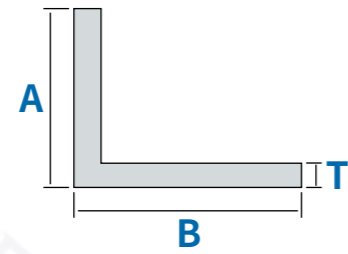

PROFILE NUMBER 型材编号	OUTER DIAMETER 外径 (MM)	THICKNESS (MM) 壁厚
	75*20	2.0
	75*25	3.0
	75*50	6.0
	75*75	2.9
	98*28	3.0
GN5000	100*50	3.0
GN1042		4.0
GN1041	100*80	4.0
GN5004	100*100	3.0
	150*75	6.0
	150*150	6.0



FLAT BAR SPECIFICATIONS 扁条规格

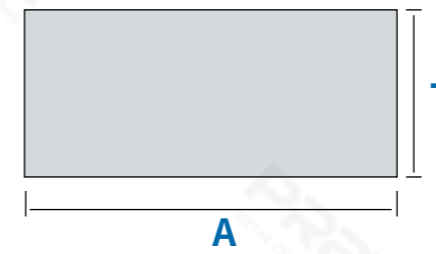

PROFILE NUMBER 型材编号	OUTER DIAMETER 外 径 (MM)	THICKNESS (MM) 壁厚
	5	3.0
	10	5.0
	15	2.0
GN2756	15	7.0
	17	13.0
	19	3.8
GN0807	20	1.5
		2.0
		3.0
		4.0
		5.0
	25	2.0
		2.5
		3.0
		4.0
		5.0
	30	2.0
		3.0
		5.0
	40	2.0
		3.0
		5.0
	50	2.0
		3.0
		4.0
		5.0
GN0884		15.0
GN0092	60	3.0
		6.0
	80	10.0
GN0624		4.0
	90	12.0
		6.0
	100	1.5
		6.0
120BT	120	16.0
150BT	150	6.0
175BT	175	2.0
200BT	200	5.0

CORNER ALUMINUM SPECIFICATIONS 封盖规格

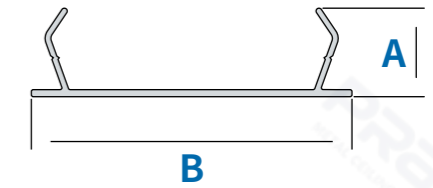

PROFILE NUMBER 型材编号	THICKNESS (MM) 壁厚
15FG	0.7
20FG	0.7
20FG-2.0	1.5(配2.0管)
25FG	1
30FG	0.7
30FG-2.0	1.5(配2.0管)
35FG	0.8
40FG	1
40FG-2.0	1.5(配2.0管)
44FG	1
50FG	1.1
GN1189(50FG)	1.1
50FG-2.0	1.5(配2.0管)
50FG-3.0	1.5(配3.0管)
60FG	1.5
60FG-2.0	1.5(配2.0管)
75FG	1.2
80FG	1.1
80FG-2.0	1.5(配2.0管)
100FG	1.2
100FG-G	1.2(配2.0管)
150FG-2.0	2.0(配2.0管)

METAL CEILING SYSTEM



**PROJECT
CASES**

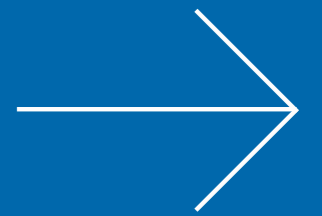

METAL FACADE SYSTEM





Tencent Digital Tower Ceiling & Interior Decoration Project

PRANCE has been awarded the prestigious contract to provide materials and installation for 31 floors in two towers for Tencent, the largest internet company in China and one of the top 10 in the world. The towers stand at 230 meters and 155 meters high respectively, and PRANCE is proud to take on the responsibility of delivering exceptional quality and service for this significant project.

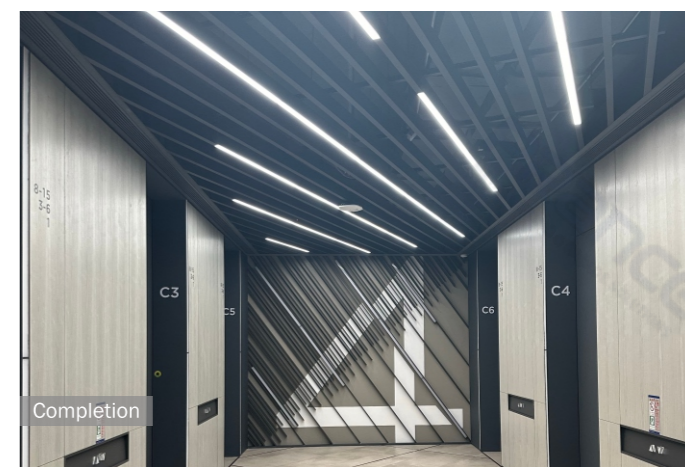
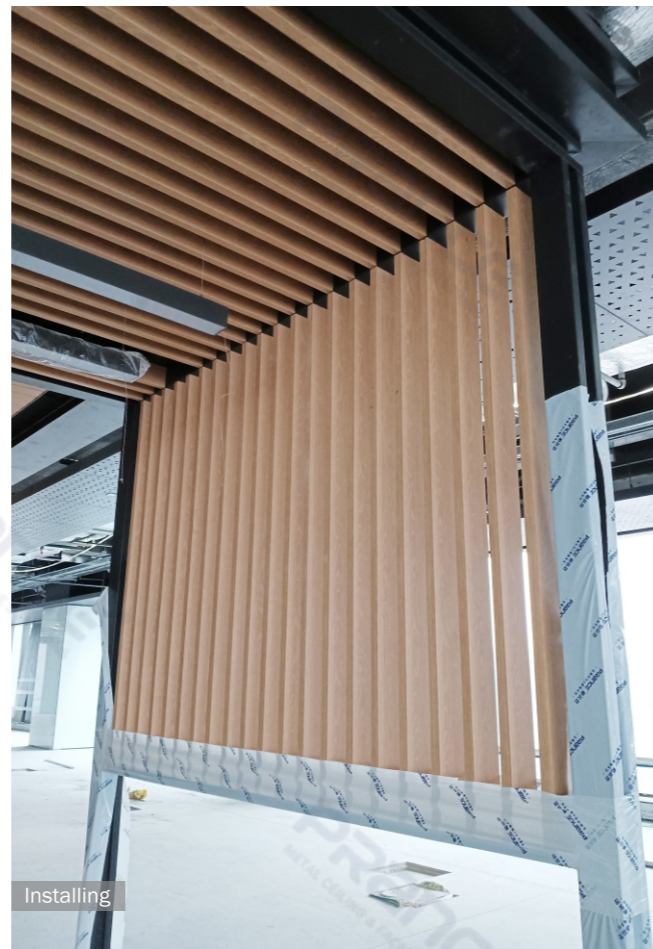

The LUXÉ 1705 - 1735

1705 N American St, -Metal Ceiling Project

The Luxe has been specializing in creating a high-quality luxury apartment collection for the Fishtown West community in Philadelphia, and the products offered by PRANCE have won the trust and praise of our clients due to their superior quality and exquisite design.

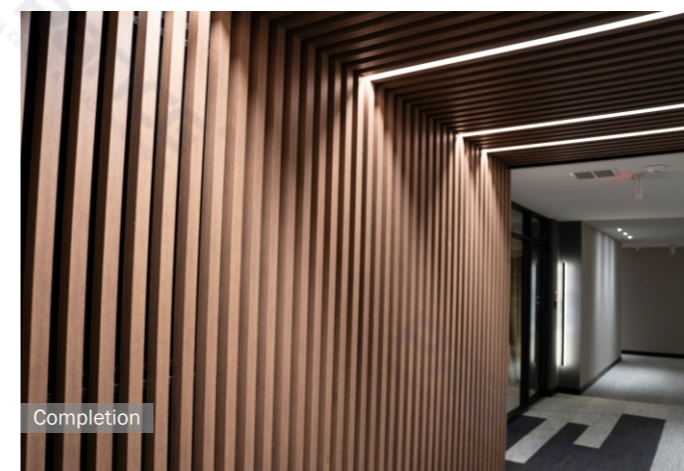
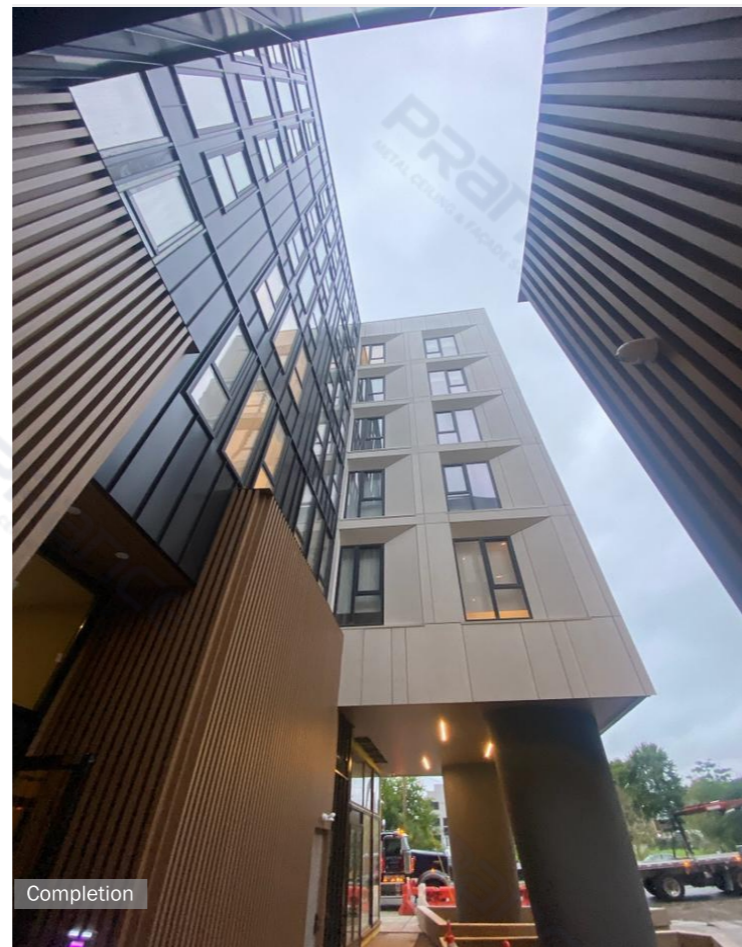

Shopping Mall Elevator Lobby Metal Wall Cladding Project

The elevator lobby walls are adorned with METAL GREAT WALL PANEL in a triangular shape. This unique design ensures the elevator area is anything but mundane, with its three-dimensional form adding a lively and engaging touch to the space.

