

Parallel Twin Screw Extruder Compounding Pelletizing System

KITECH MACHINERY CO.,LTD

KTS series Compounding Pelletizing Machine

KTS twin screw extruder is Cost-effective solution for normal scale batch production, especially for color master-batch, filler Masterbatch, Plastic modification, Fiber glass reinforcement, cable compounds, Alloy or engineering plastics, power coating , recycling plastics pelletizing application.

The production of master batch has strict requirements on equipment and process. The accurately measured powder or additives need to be evenly dispersed and mixed into the carrier resin. It can equipped with mixer unit or gravimetric dosing units to accurately transmit the elements to the compounding system. Our twin screw extruder is providing high output, excellent self-cleaning ability, and excellent mixing effect based on flexible design of screw structure.



• Parameter of KTS Series model Parallel Twin Screw Extruder

Model	Unit	KTS35	KTS50	KTS65	KTS75	KTS95	KTS135
Screw diameter	mm	35	50	65	75	95	135
Screw speed	rpm	500-600	500-600	500-600	500-600	500-600	500-600
Motor power	kW	15-22kW	30-55kW	45-90Kw	110-160kW	250-315kW	400-500kW
L/D ratio range		22-68	22-68	22-68	22-68	22-68	22-48
Through out	Kg/h	20-50	80-220	150-450	280-800	500-1500	1500-3000

KTS Plus series Compounding Pelletizing Machine

KTS Plus twin screw extruder is high effective solution for high scale batch production, The whole machine has high stability and high efficiency, which can win the market competitiveness for users while taking into account the green and energy-saving.



- Parameter of KTS Plus Series model Parallel Twin Screw Extruder

Model	Unit	KTS35 +	KTS50+	KTS65+	KTS75+	KTS95+	KTS135+
Screw diameter	mm	35	50	65	75	95	135
Screw speed	rpm	900	900	900	900	900	800
Motor power	kW	30-45kW	90-132kW	160-250kW	250-355kW	500-710kW	1800kW
L/D ratio range		22-68	22-68	22-68	22-68	22-68	22-48
Through out	Kg/h	50-220	200-600	400-1200	600-1800	1000-3000	2000-6000

Screw & Barrel



Gearbox



Torque Limit Clutch



Other Auxiliary Equipment



Filter

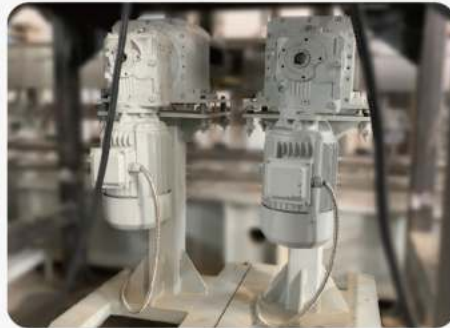

Side force Feeder



Degassing Unit



Melt Pump



Gravimetric doser
for solid materials



Gravimetric doser
for liquid



Mixer

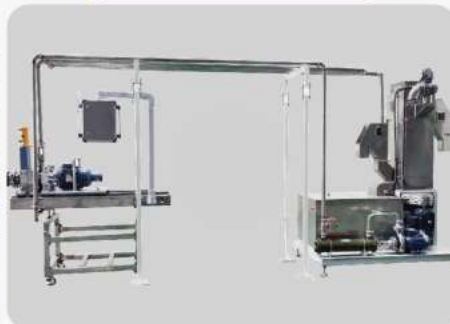

Under-water
Pelletizing System



Strand Pelletizing Cutter

Pelletizing System

• Strand Type Pelletizing

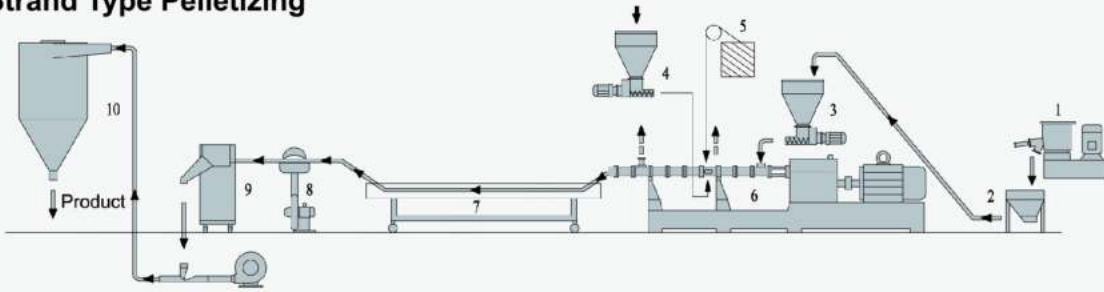

1. high speed mixer 2. solids-conveyer 3. main feeder 4. side feeder 5. glass fiber
6. twin screw extruder 7. water trough 8. air-knife 9. pelletizer 10. product container

• Water-ring Pelletizing

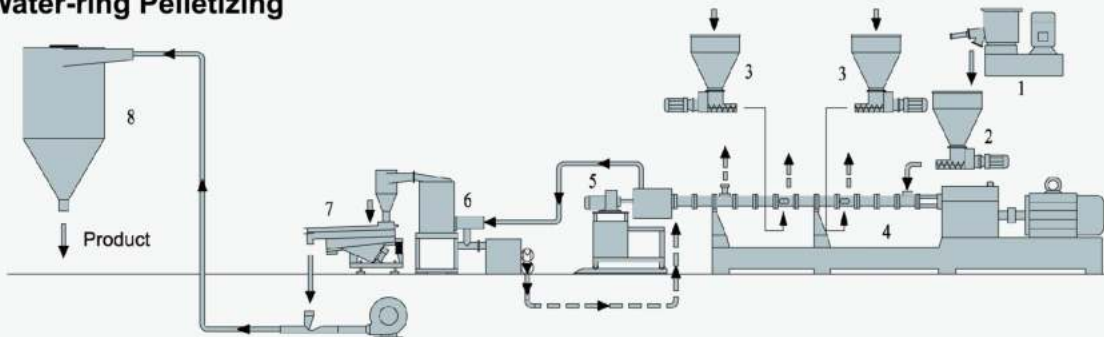

1. high speed mixer 2. main feeder 3. side feeder 4. twin screw extruder 5. water-ring granulator
6. centrifugal deater 7. vibrating sieve 8. product container

• Air Cooling Pelletizing

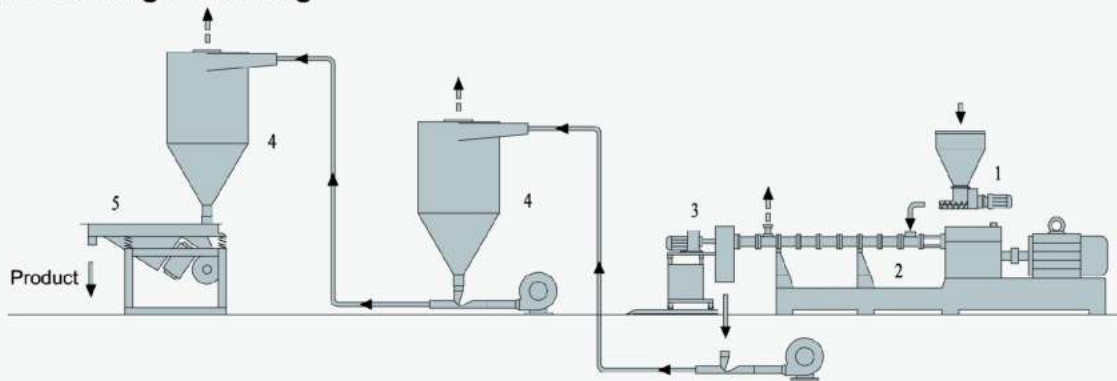

1. metering feeder 2. twin screw extruder 3. air-cooling hot-face pelletizer 4. cyclone
5. vibrating screen

• Double Stage Pelletizing

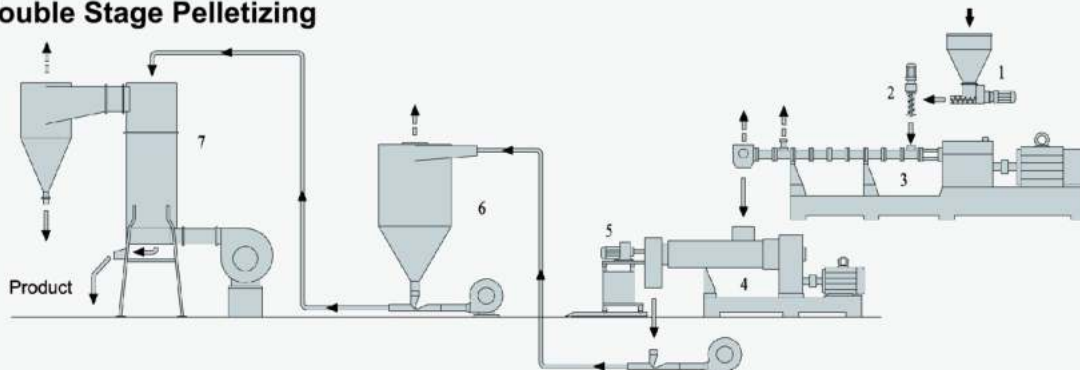

1. metering feeder 2. cramming feeder 3. twin screw extruder 4. single screw extruder
5. hot-face cutter with air cooling 6. cyclone 7. fluidizing bed

Representative materials working capability schedule of KTS-series Co-rotating parallel twin screw extruder (reference values)

Twin – screw compounding extruder KTS...		KTS – 35	KTS – 50	KTS – 65	KTS – 75	KTS – 95
Technological process	Typical material	Production capacity kg/h (is related to material and processing technology)				
Mixing nature-changing	PE, PA, PE+EPDA; PE, PP, PS+SBS... ..	40 ~ 80	100 ~ 180	160 ~ 280	350 ~ 500	700 ~ 1100
	PP+PE, PBT+PET; PA, PC, CPE... ..	30 ~ 50	80 ~ 180	160 ~ 250	300 ~ 400	600 ~ 1000
Filling nature-changing	PE, PP, PS, EVA... ..+calcium carbonate, talcum powder, titanium dioxide	30 ~ 60	100 ~ 200	200 ~ 400	350 ~ 550	700 ~ 1000
	PP, PA6, PA66, ABS+Iron powder, magnetic powder, ceramic powder	50 ~ 90	120 ~ 250	250 ~ 400	400 ~ 600	900 ~ 1200
General and fibre masterbatch	PE, PP, PS, ABS, EVA, PET... ..+inorganic or organic pigments	30 ~ 50	80 ~ 150	150 ~ 250	250 ~ 350	500 ~ 750
Functional color masterbatch	Carbon black masterbatch: PE, PP, PS, ABS, EVA... ..+Carbon black	20 ~ 40	60 ~ 100	120 ~ 200	220 ~ 300	400 ~ 600
	Flame Retardant Masterbatch: PE, ABS, PA, PBT... ..+flame retardants and additives	40 ~ 70	80 ~ 160	160 ~ 260	240 ~ 400	550 ~ 950
	Degradable masterbatch: PE+PS... ..+starch; PP+calcium carbonate, talcum powder	30 ~ 60	80 ~ 140	140 ~ 200	240 ~ 360	600 ~ 800
	Double anti-masterbatch:degradable masterbatch, high insulation masterbatch; rheological modification masterbatch	25 ~ 40	60 ~ 90	620 ~ 180	160 ~ 260	400 ~ 700
Glass fibre (carbon fibre) reinforcement	PE, ABS, AS, PBT, PET, PA, PC, PPS+carbon fiber	30 ~ 60	60 ~ 140	140 ~ 200	220 ~ 300	500 ~ 700
	PE, ABS, AS, PBT, PET, PA, PC, PPS, PPO... ..	25 ~ 45	80 ~ 140	180 ~ 260	280 ~ 360	550 ~ 750
Various cable material	HDPE, LDPE, LLDPE, MDPE insulation material, sheath material	30 ~ 60	90 ~ 140	160 ~ 240	250 ~ 350	450 ~ 650
	PE silane cross-linked, PE radiation cross-linked, PE cross-linked shielded cable compound	25 ~ 50	80 ~ 120	140 ~ 200	220 ~ 300	400 ~ 600
Power coating	Low-smoke and low-halogen PVC cable compound, low-smoke halogen-free polyolefin cable material	40 ~ 80	120 ~ 180	200 ~ 300	300 ~ 400	500 ~ 700
	Polyester type, polyurethane type, epoxy type, propyl ester type	60 ~ 100	150 ~ 250	300 ~ 400	400 ~ 600	800 ~ 1000

Representative materials working capability schedule of KTS-series twin/single screw two-stage extruder package (reference values)

KTS Two-stage compounding extruder KTS		KTS 50/100	KTS 65/150	KTS 75/150	KTS 95/200
Technological process	Typical material	Production capacity kg/h (is related to material and processing technology)			
Heat-sensitive polymer Processing	PVC cable material, Low-smoke, low-halogen or halogen-free flame retardant cable material Foam sole material, Vascular material	150 ~ 300	250 ~ 400	400 ~ 800	700 ~ 1500
	PE silane cross-linked cable compound, PE cross-linked pipe material, Peroxide cross-linked cable compound	120 ~ 150	200 ~ 400	300 ~ 800	500 ~ 1000

JIANGSU KITECH MACHINERY CO.,LTD

Email : info@kitechpm.com

Tel : +86-512-5862 0105

Fax : +86-512-5896 2531

Web : www.kitechpm.com

Add : No.7 Jiulong industry park, Jinfeng Town, Zhangjiagang City, Jiangsu, China