

# ABRASIVES



深圳市永昌源科技开发有限公司

ShenzhenYongchangyuan Technology Development Co., Ltd

Dental Burs 牙科车针、磨头

Vol. 8 : 2024

# About Us

Yongchangyuan Technology Development Co., Ltd Abrasives Company Limited are specialized in Rotary things of dental, Jewelry, Beauty or Hobbies & DIY ( Do it Yourself ) .

Our products include Diamond Burs and discs, Tungsten Carbide Burs or cutters, Flexible Rubber Burs, Wheels or Points, Polishing Brushes, Mounted Stones, CAD/CAM Milling Burs or any Diamond Stones or Polishers.

Our Rotatory Instruments are widely applied to Cut, Grind, Finish, Polish any materials of Zirconia, Lithium Disilicates, Porcelain (Ceramics) , Alloy or Metal, Acrylic ( Resin ) , PEEK, Composites etc . They can match any Handpiece of FG (Friction Grip) , RA/CA(Right Angle), HP conveniently and precisely .

We have obtained the certificates of ISO 13485 and CE since the year of 2015 . We provide innovative and professional products and service.

Whoever you are dentist or technician, we always make you relaxing, safe and efficient. We are your best friend in dentistry, Jewellery or Hobbies.

Our Product Has the Ability to fulfill Your Standard and Sensational Satisfaction. We are anticipating to have you as one of our important clients with Best Wishes.



ISO 13485



CE 0197



Established in 2007



**Laboratory Part**  
技工类

Page 33-66 第33-66页



**Diamond bur 金刚石磨头**

Page 34-35 第34-35页

**Fully-sintered Diamond bur**  
全砂烧结磨头

Page 36-37 第36-37页

**Sintered Diamond Disc**  
**Diamond Disc**

烧结切片、金刚石切片

Page 38-40 第38-40页

**CAD / CAM Milling Bur**  
铣刀

Page 41-43 第41-43页

**Tungsten Carbide bur**  
钨钢车针

Page 44-47 第44-47页

**Diamond Stones & Polisher**  
陶瓷(橡胶) 结合剂金刚石磨头  
(全瓷、全锆磨头)

Page 48-52 第48-52页

**Silicon Polisher**  
硅胶抛光磨头

Page 53-54 第53-54页

**Mounted stone, Sandpaper**  
车石、砂纸棒

Page 55 第55页

**Polishing Brushes, Felt burs**  
**Mandrels**

抛光刷、毛毡磨头、夹针

Page 56-58 第56-58页

**Hard Z Cutter etc .**  
硬锆磨头等

Page 59 第59页

**Kit 套装**

Page 60-62 第60-62页

**Samples Collection**  
样品册

Page 63 第63页

**FlexSoft Partial Denture**  
隐形义齿胶

Page 64 第64页

**Diamond Bur HP  
(Electroplated)  
金刚石磨头 (电镀)**



Sharp and Durable,  
Grind or polish Ceramics  
锋利、耐用  
磨削平稳、不偏摆  
不留黑印、适合车瓷



**Grit**

- Black / Super Coarse
- Green / Coarse
- Blue / Medium
- Red / Fine

**Fine Red  
细砂  
红圈**



编号 No. FD30 FK33 FA23 FA33 FC18 FC25 FM27 FL33 FN23 FP33

This grit can grind Zirconia 可用于车氧化锆

**Medium Blue  
标准砂  
蓝圈**

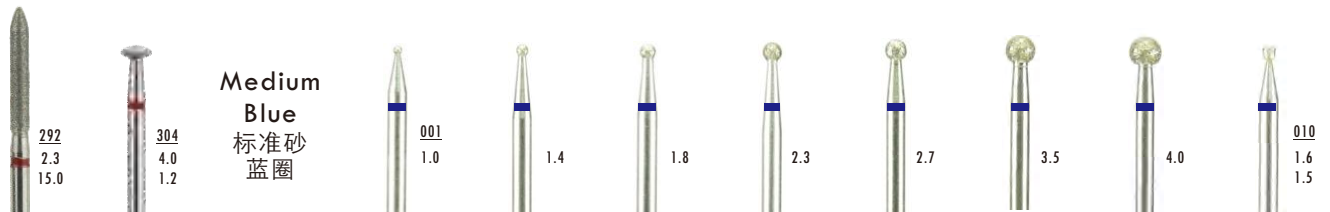

FQ23 FU40 编号 No. MD10 MD14 MD18 MD23 MD27 MD35 MD40 MK16

Round / 圆球

Inverted Cone

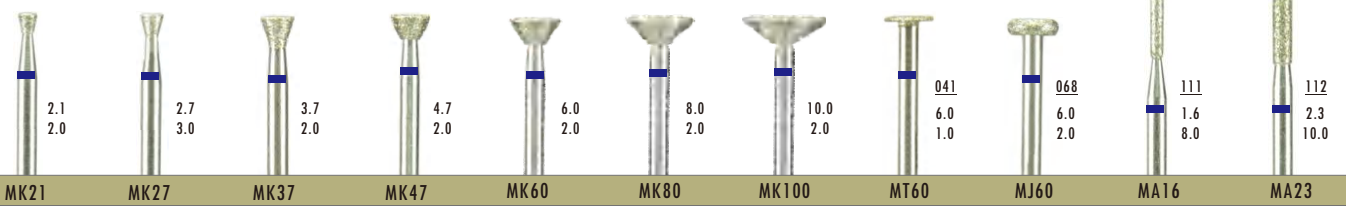

MK21 MK27 MK37 MK47 MK60 MK80 MK100 MT60 MJ60 MA16 MA23

Wheel / 平轮

Cylinder / 平柱

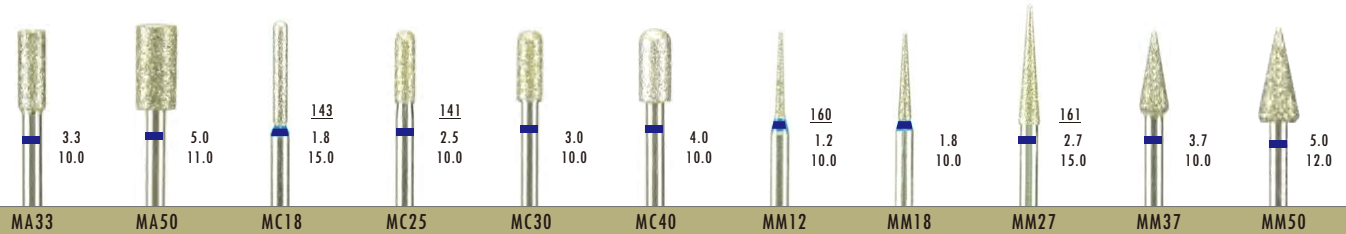

MA33 MA50 MC18 MC25 MC30 MC40 MM12 MM18 MM27 MM37 MM50

Round Cylinder / 圆头柱

Needle / 尖针

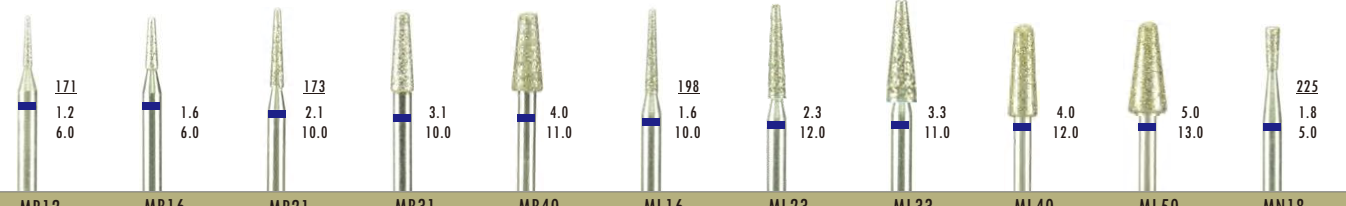

MB12 MB16 MB21 MB31 MB40 ML16 ML23 ML33 ML40 ML50 MN18

Taper / 平锥

Round Taper / 圆头锥

Inverted Cone

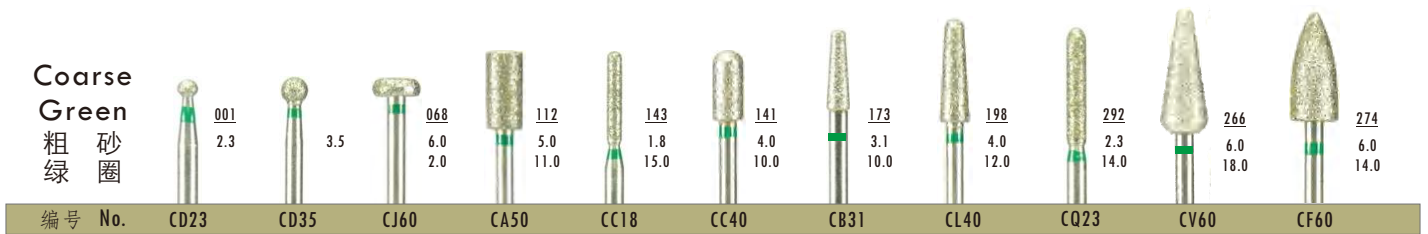
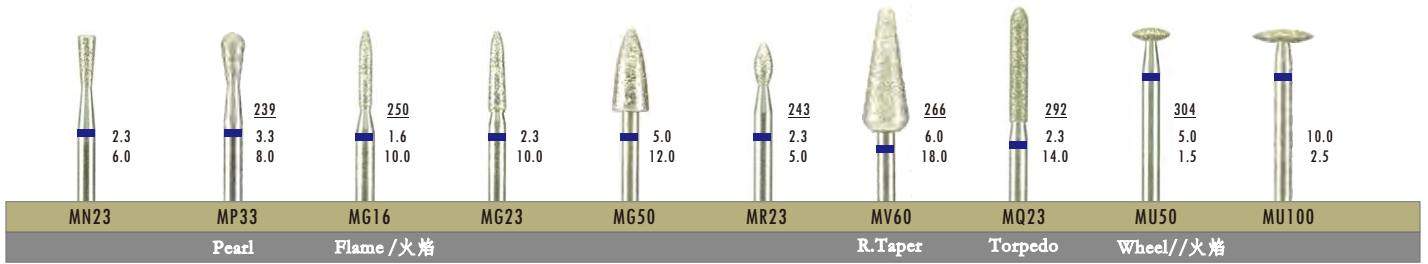

Transparent Showing plates  
展示台 120x120x8mm

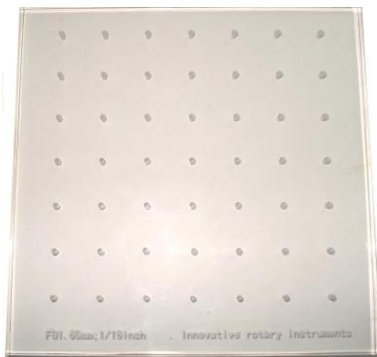

No. 1216

7 x 7 holes  
1.60mm, for FG burs

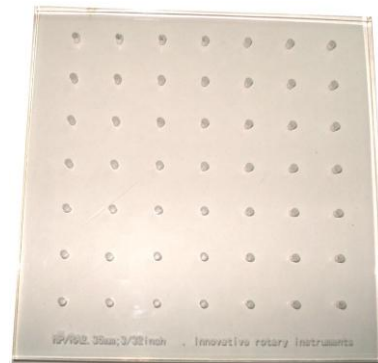

No. 1223

7 x 7 holes  
2.35mm, for RA or HP burs.

# Fully-Sintered Diamond Bur . HP

全砂烧结磨头



Extremely Durable,  
Grind or polish smoothly  
Especial for Metal

从里到外都是砂  
平稳、耐用，适合车金

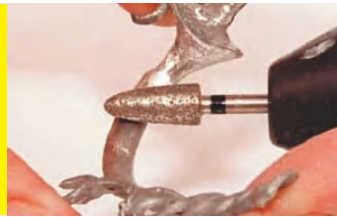

## Grit

- Black/Super Coarse
- Green/Coarse
- Blue/Medium
- Red/Fine
- Yellow/Extra Fine

### Super Coarse Black 特粗砂黑圈

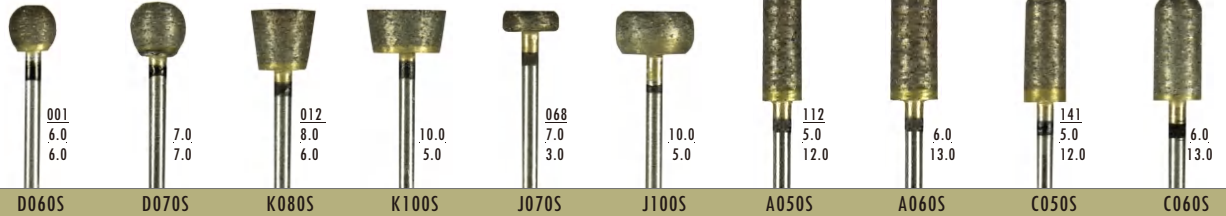

### Coarse Green 粗砂绿圈

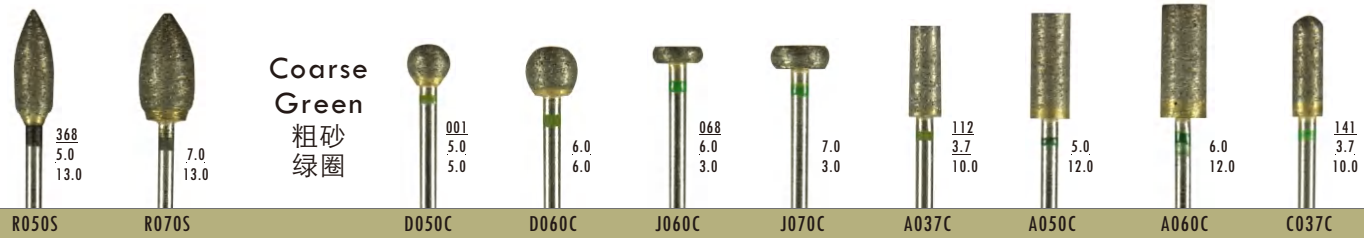

### Medium Blue 标准砂蓝圈

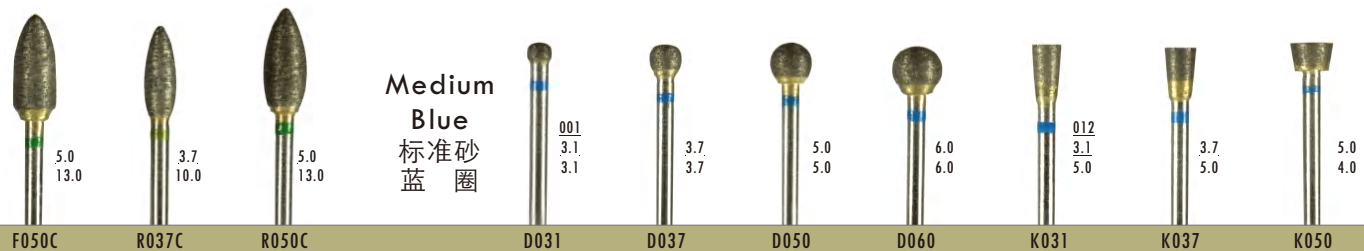



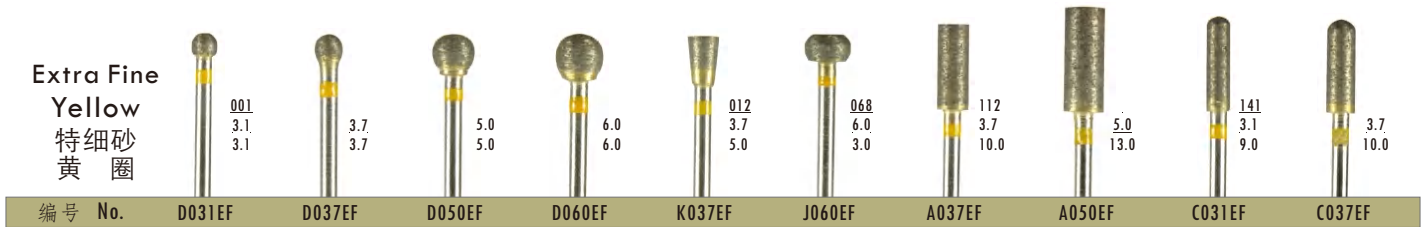
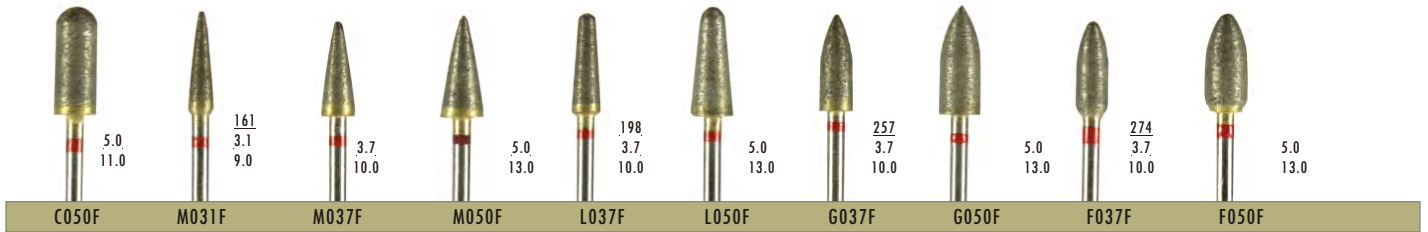
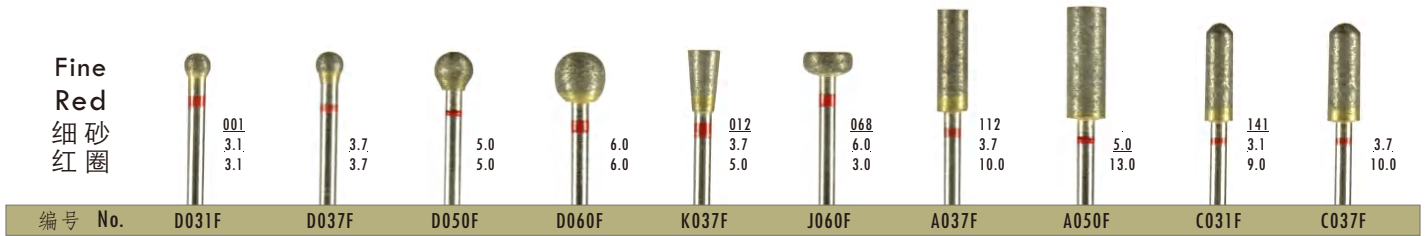
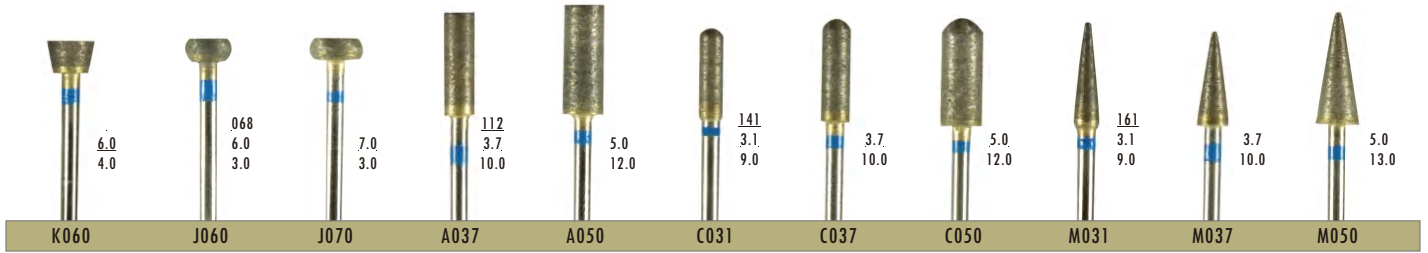

# Sintered Diamond Disc

烧结切割片

Grinding or Trimming of sintered Zirconia or any other Extra hard workpiece

用于切割烧结后的氧化锆或者各种超硬材质工件。

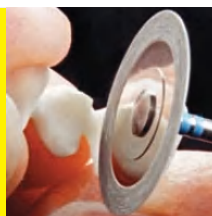

The galvanically sintered edge of the diamond discs offers excellent cutting performance.

提供三种不同粒度的砂粒，供您试用。



70 µm

Item No.



1

S394/190/0.25mm

S394/220/0.25mm

S394/190/0.30mm

S394/220/0.30mm

Size (mm)

19 x 0.25mm

22 x 0.25mm

19 x 0.3mm

22 x 0.3mm

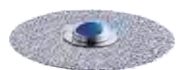

60 µm

Item No.



1

S395/190/0.25mm

S395/220/0.25mm

S395/190/0.30mm

S395/220/0.30mm

Size (mm)

19 x 0.25mm

22 x 0.25mm

19 x 0.3mm

22 x 0.3mm



40 µm

Item No.



1

S396/190/0.25mm

S396/220/0.25mm

S396/190/0.30mm

S396/220/0.30mm

Size (mm)

19 x 0.25mm

22 x 0.25mm

19 x 0.3mm

22 x 0.3mm



# Diamond Disc

金刚石切片



How to order these Discs:

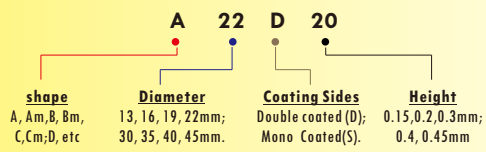

Extra Thin, 0.15mm  
Double sided  
Extra Fine  
超薄, 双面砂



编号 No.      A19D15      A22D15      Am13D15      Am16D15      Am19D15      Am22D15

Thin, 0.20 x 19mm  
Double sided  
Fine Grit  
较薄, 双面砂

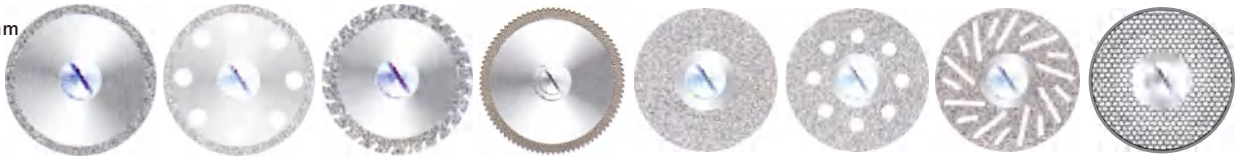

编号 No.      A19D20      B19D20      C19D20      N19D20      Am19D20      Bm19D20      Em19D20      Hm19D20

Thin, 0.20 x 22mm  
Double sided  
Fine Grit  
较薄, 双面砂



编号 No.      Am22D20      Bm22D20      Cm22D20      Em22D20      Im22D20      Jm22D20      Hm22D20



A22D20      B22D20      C22D20      E22D20      F22D20      H22D20      J22D20      N22D20

Hard, 0.3 - 0.4mm  
Double sided  
Medium Grit  
厚硬, 双面砂



编号 No.      Am19D30      Am22D30      Am22D40      A19D40      A22D40  
19.0 x 0.3 mm      22.0 x 0.3 mm      22.0 x 0.4 mm      19.0 x 0.4 mm      22.0 x 0.4 mm

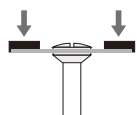

Single-sided  
仅单面镀砂



编号 No.      A22S20      Am22S20      Am22S30  
22.0 x 0.2 mm, Fine      22.0 x 0.2 mm      22.0 x 0.3 mm, Medium

Fast Cutting  
Plaster Disc ,  
0.3mm,  
Double sided  
石膏模切片  
平整、无偏摆

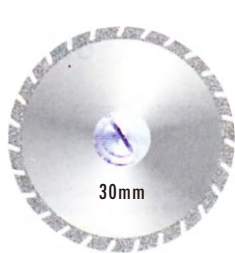

30mm



35mm

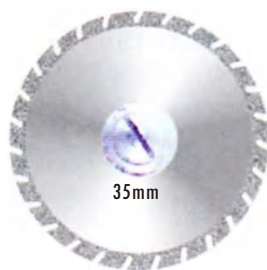

35mm

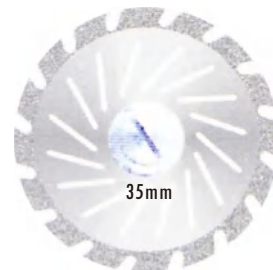

35mm

编号 No.

C30D30

A35D30

C35D30

J35D30

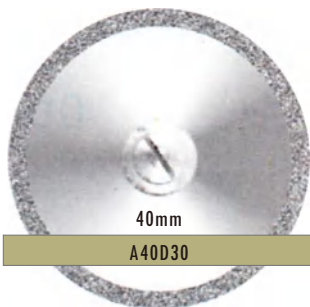

40mm

A40D30

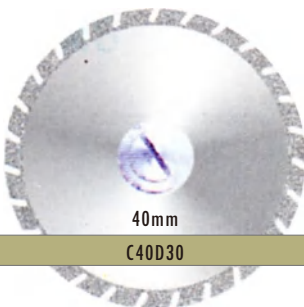

40mm

C40D30



40mm

J40D30



45mm

Cb45D30

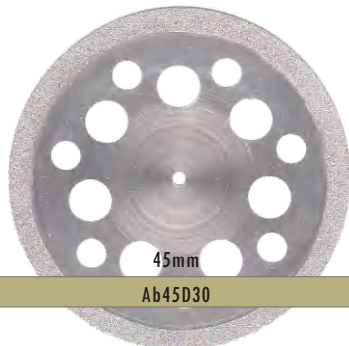

45mm

Ab45D30

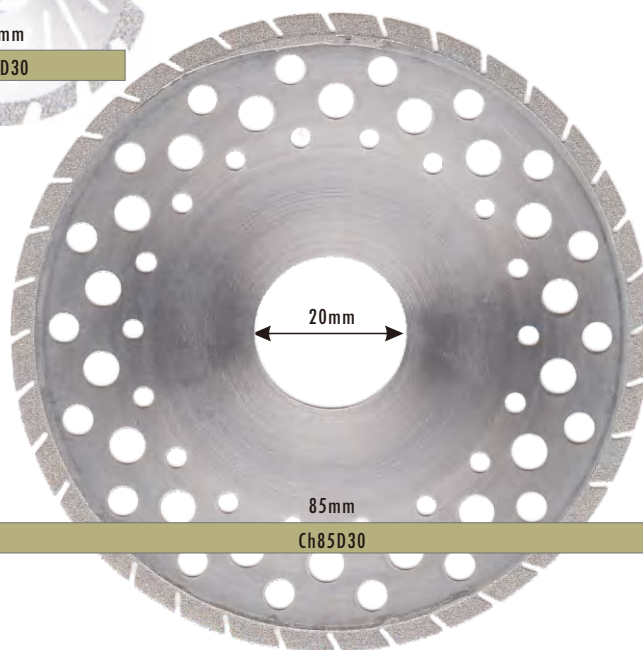

20mm

85mm

Ch85D30

Article No	Coating	D1	L1	L2	L3	D2
for Roland 00						
RL-00-06-ED	Dia.	0.6/1.5	9.0	—	40	3.0
RL-00-10-ED	Dia.	1.0	6.0	—	40	3.0
RL-00-25-ED	Dia.	2.5	15.0	—	40	3.0

Article No	Coating	D1	L1	L2	L3	D2
for Amann Girrbach 00						
AG-00-04-ED	Dia.	0.4	6.5	—	43	3.0
AG-00-10-ED	Dia.	1.0	14.0	—	43	3.0
AG-00-14-ED	Dia.	1.4	14.0	—	43	3.0
AG-00-18-ED	Dia.	1.8	14.0	—	43	3.0

Article No	Coating	D1	L1	L2	L3	D2
for VHF						
VH-00-06-ED	Dia.	0.6	6.0	—	35	3.0
VH-00-10-ED	Dia.	1.0	9.0	—	35	3.0
VH-00-25-ED	Dia.	2.5	16.0	—	35	3.0

Article No	Coating	D1	L1	L2	L3	D2
for Imes-Icore 350, 550, 750						
II-75-06-ED	Dia.	0.6	10.0	—	40	6.0
II-75-10-ED	Dia.	1.0	10.0	—	40	6.0
II-75-25-ED	Dia.	2.5	15.0	—	40	6.0

Article No	Coating	D1	L1	L2	L3	D2
for Imes-Icore 240, 250						
II-24-06-ED	Dia.	0.6	10.0	—	43	3.0
II-24-10-ED	Dia.	1.0	10.0	—	45	3.0
II-24-25-ED	Dia.	2.5	15.0	—	42	3.0

## CAD / CAM Milling Burs for Lithium Disilicate 铣刀(加工玻璃陶瓷)

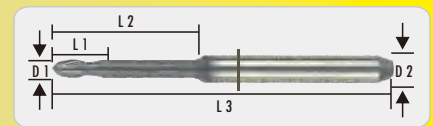

D1 : Cutting Edge Diameter (.mm) L1 : Cutting Edge Length (.mm)  
D2 : Shank Diameter (.mm) L2 : Free Grinding to (.mm)  
L3 : Total Length (.mm)

Article No	Coating	D1	L1	L2	L3	D2
for Sirona MCX5						
SR-X5-06-ED	Dia.	0.6	14.5	—	34.5	3.0
SR-X5-12-ED	Dia.	1.2	12.5	—	36.5	3.0
SR-X5-14-ED	Dia.	1.4	14.5	—	35.5	3.0
SR-X5-22-ED	Dia.	2.2	15.5	—	37.5	3.0

Article No	Coating	D1	L1	L2	L3	D2
for Sirona MCXL						
SR-XL-C125-ED	Dia.	—	13.7	—	38	3.5
Cylinder Pointed Bur 125						
SR-XL-S125-ED	Dia.	—	13.7	—	38	3.5
Step Bur 125						
SR-XL-S12-ED	Dia.	—	13.2	—	38	3.5
Step Bur 12						

Article No	Coating	D1	L1	L2	L3	D2
for Sirona MCXL						
SR-XL-CP12EF-ED	Dia.	—	19.0	—	40	3.5
Cylinder Pointed Bur 12EF						
SR-XL-C12EF-ED	Dia.	—	19.0	—	40	3.5
Cylinder Bur 12EF						

Article No	Coating	D1	L1	L2	L3	D2
for Sirona MCXL						
SR-XL-C20-ED	Dia.	—	21.5	—	46	3.5
Cylinder Pointed Bur 20						
SR-XL-S20-ED	Dia.	—	22.0	—	46.3	3.5
Step Bur 20						

Article No	Coating	D1	L1	L2	L3	D2
for Sirona Cerec 3						
SR-C3-CP-ED	Dia.	—	9.3	—	23.5	1.8
Cylinder Pointed Bur						
SR-C3-12S-ED	Dia.	—	13.2	—	25.2	1.8
Step Bur 12						
SR-C3-10S-ED	Dia.	—	11.5	—	23.3	1.8
Step Bur 10						

Article No	Coating	D1	L1	L2	L3	D2
for Dentium						
DT-00-06-ED	Dia.	0.6	19.8	—	50	6.0
DT-00-10-ED	Dia.	1.0	19.8	—	50	6.0
DT-00-20-ED	Dia.	2.0	19.8	—	50	6.0

Article No	Coating	D1	L1	L2	L3	D2
for Dentium						
DT-01-10-ED	Dia.	1.0	10.0	—	45	3.0
DT-01-20-ED	Dia.	2.0	12.0	—	45	3.0

Article No	Coating	D1	L1	L2	L3	D2
for Arum						
AR-00-10-ED	Dia.	1.0	10.5	—	50	6.0
AR-00-15-ED	Dia.	1.5	12.5	—	50	6.0
AR-00-20-ED	Dia.	2.0	12.5	—	50	6.0
AR-00-25-ED	Dia.	2.5	12.5	—	50	6.0

Article No	Coating	D1	L1	L2	L3	D2
for Arum 400						
AR-01-06-ED	Dia.	0.6	12.5	—	41	4.0
AR-01-10-ED	Dia.	1.0	16.0	—	44.5	4.0
AR-01-15-ED	Dia.	1.5	16.0	—	44.5	4.0
AR-01-25-ED	Dia.	2.5	16.0	—	44.5	4.0



# CAD / CAM Milling Burs.

## 铣刀

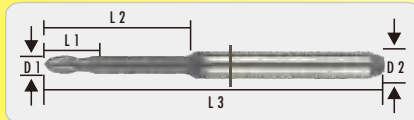

**D1** : Cutting Edge Diameter (.mm)    **L1** : Cutting Edge Length (.mm)  
**D2** : Shank Diameter (.mm)            **L2** : Free Grinding Length (.mm)  
**L3** : Total Length (.mm)

### Coating

CrN : for PMMA  
 AL : for Metal  
 NC : for Zirconia  
 DC : for Zirconia,  
 More Durable.



Article No	Coating	D1	L1	L2	L3	D2
for Roland 50						
RL-50-03-NC	NC	0.3	1.5	6.0	50.0	4.0
RL-50-06-CRN	CRN	0.6	1.5	6.0	50.0	4.0
RL-50-06-NC	NC					
RL-50-10A-CRN	CRN	1.0	3.5	16.0	50.0	4.0
RL-50-10A-NC	NC					
RL-50-20A-CRN	CRN	2.0	6.0	16.0	50.0	4.0
RL-50-20A-NC	NC					
RL-50-20A-DC	DC					
RL-50-10B-CRN	CRN	1.0	3.5	20.0	50.0	4.0
RL-50-10B-NC	NC					
RL-50-20B-CRN	CRN	2.0	6.0	25.0	52.0	4.0
RL-50-20B-NC	NC					
RL-50-20B-DC	DC					

Article No	Coating	D1	L1	L2	L3	D2
for 3 M ESPE LAVA						
LV-00-10-CRN	CRN	1.0	3.5	16.0	38.0	3.0
LV-00-10-NC	NC					
LV-00-20-CRN	CRN	2.0	6.0	16.0	38.0	3.0
LV-00-20-NC	NC					
LV-00-20-DC	DC					
LV-01-10-CRN	CRN	1.0	2.0	25.0	50.0	3.0
LV-01-10-NC	NC					
LV-01-20-CRN	CRN	2.0	2.0	25.0	50.0	3.0
LV-01-20-NC	NC					
LV-01-20-DC	DC					

Article No	Coating	D1	L1	L2	L3	D2
for RK						
RK-00-10-DC	DC	1.0	3.5	16.0	47.0	3.0
RK-00-20-DC	DC	2.0	3.5	16.0	47.0	3.0

Article No	Coating	D1	L1	L2	L3	D2
for Imes-Icore 240, 250						
II-24-06-CRN	CrN	0.6	1.5	10.0	48.0	3.0
II-24-06-NC	NC					
II-24-10-CRN	CrN	1.0	5.0	14.0	48.0	3.0
II-24-10-NC	NC					
II-24-25-CRN	CrN	2.5	8.0	20.0	48.0	3.0
II-24-25-NC	NC					
II-24-25-DC	DC					

Article No	Coating	D1	L1	L2	L3	D2
for Imes-Icore 350, 550, 750						
II-75-06-CRN	CrN	0.6	2.5	12.0	53.0	6.0
II-75-06-NC	NC					
II-75-10-CRN	CrN	1.0	6.0	14.0	53.0	6.0
II-75-10-NC	NC					
II-75-25-CRN	CrN	2.5	10.0	20.0	53.0	6.0
II-75-25-NC	NC					
II-75-25-DC	DC					

Article No	Coating	D1	L1	L2	L3	D2
for Amann Girrbach						
AG-00-06-CRN	CrN	0.6	1.5	13.0	47.0	3.0
AG-00-06-NC	NC					
AG-00-10-CRN	CrN	1.0	3.5	16.0	47.0	3.0
AG-00-10-NC	NC					
AG-00-25-CRN	CrN	2.5	5.0	16.0	47.0	3.0
AG-00-25-NC	NC					
AG-00-25-DC	DC					

Article No	Coating	D1	L1	L2	L3	D2
for Amann Girrbach - Metal mill						
AG-01-10-AL	Alnova	1.0	5.0	7.0	43.0	3.0
AG-01-20-AL	Alnova	2.0	5.0	7.0	43.0	3.0

Article No	Coating	D1	L1	L2	L3	D2
for VHF K1, K4						
VH-K4-06-CRN	CRN	0.6	2.0	7.0	35.0	3.0
VH-K4-06-NC	NC					
VH-K4-10-CRN	CRN	1.0	3.5	16.0	35.0	3.0
VH-K4-10-NC	NC					
VH-K4-20-CRN	CRN	2.0	5.0	16.0	35.0	3.0
VH-K4-20-NC	NC					

Article No	Coating	D1	L1	L2	L3	D2
for VHF K5						
VH-K5-03-NC	CRN	0.3	1.2	13.0	40.0	3.0
VH-K5-06-CRN	CRN	0.6	1.5	7.0	40.0	3.0
VH-K5-06-NC	NC					
VH-K5-10-CRN	CRN	1.0	3.5	14.0	40.0	3.0
VH-K5-10-NC	NC					
VH-K5-20-CRN	CRN	2.0	4.5	16.0	40.0	3.0
VH-K5-20-NC	NC					
VH-K5-20-DC	DC					

Article No	Coating	D1	L1	L2	L3	D2
for Dentium						
DT-00-10-NC	NC	1.0	3.5	16.0	50.0	6.0
DT-00-20-NC	NC	2.0	3.5	16.0	50.0	6.0
DT-00-20-DC	DC					
DT-01-05-NC	NC	0.5	2.0	8.0	43.0	3.0
DT-01-10-CrN	CrN	1.0	3.5	16.0	50.0	3.0
DT-01-10-NC	NC					
DT-01-20-CrN	CrN	2.0	3.5	18.0	50.0	3.0
DT-01-20-NC	NC					
DT-01-20-DC	DC					

Article No	Coating	D1	L1	L2	L3	D2
for Zirkon Zahn M3						
ZZ-03-05-CrN	CrN	0.5	1.5	6.0	57.0	3.0
ZZ-03-05-NC	NC					
ZZ-03-10-CrN	CrN	1.0	6.0	12.0	57.0	3.0
ZZ-03-10-NC	NC					
ZZ-03-20-CrN	CrN	2.0	10.0	18.0	57.0	3.0
ZZ-03-20-NC	NC					
ZZ-03-20-DC	DC					

Article No	Coating	D1	L1	L2	L3	D2
for Zirkon Zahn M5, M6, etc						
ZZ-06-05-NC	NC	0.5	1.5	3.0	50.0	6.0
ZZ-06-10-NC	NC	1.0	6.0	12.0	50.0	6.0
ZZ-06-20-NC	NC	2.0	10.0	18.0	50.0	6.0
ZZ-06-20-DC	DC					

Article No	Coating	D1	L1	L2	L3	D2
for Sirona MX 5						
SR-MX-05-NC	NC	0.5	1.5	5.0	42.0	3.0
SR-MX-10-NC	NC	1.0	4.5	18.0	43.0	3.0
SR-MX-25-NC	NC	2.5	7.0	25.0	43.0	3.0
SR-MX-25-DC	DC					

Article No	Coating	D1	L1	L2	L3	D2
for Cercon						
CC-00-05-NC	NC	0.5	2.0	10.0	55.0	3.5
CC-00-10-NC	NC	1.0	8.0	30.0	55.0	3.5
CC-00-20-NC	NC	2.0	10.0	30.0	55.0	3.5

Article No	Coating	D1	L1	L2	L3	D2
for Arum						
AR-00-10-CrN	CrN	1.0	2.0	16.0	55.0	6.0
AR-00-10-NC	NC					
AR-00-20-CrN	CrN	2.0	6.0	20.0	55.0	6.0
AR-00-20-NC	NC					
AR-00-20-DC	DC					

Article No	Coating	D1	L1	L2	L3	D2
for Wieland Mini						
WL-MI-07-CrN	CrN	0.7	1.5	7.0	35.0	3.0
WL-MI-07-NC	NC					
WL-MI-10-CrN	CrN	1.0	3.5	16.0	35.0	3.0
WL-MI-10-NC	NC					
WL-MI-25-CrN	CrN	2.5	3.5	20.0	35.0	3.0
WL-MI-25-NC	NC					

Article No	Coating	D1	L1	L2	L3	D2
for Wieland S1						
WL-S1-07-CrN	CrN	0.7	1.5	7.0	40.0	3.0
WL-S1-07-NC	NC					
WL-S1-10-CrN	CrN	1.0	3.5	16.0	40.0	3.0
WL-S1-10-NC	NC					
WL-S1-25-CrN	CrN	2.5	5.0	20.0	40.0	3.0
WL-S1-25-NC	NC					
WL-S1-25-DC	DC					

Article No	Coating	D1	L1	L2	L3	D2
for Kavo						
KA-00-10-DC	DC	1.0	2.0	16.0	53.0	6.0
KA-00-20-DC	DC	2.0	6.0	19.5	53.0	6.0

Article No	Coating	D1	L1	L2	L3	D2
for Yena						
YN-00-10-NC	NC	1.0	3.5	16.0	45.0	4.0
YN-00-20-NC	NC	2.0	3.5	16.0	45.0	4.0
YN-00-20-DC	DC					

Article No	Coating	D1	L1	L2	L3	D2
for Arum - Metal Mill						
AR-01-10-AL	Alnova	1.0	2.0	10.0	50.0	6.0
AR-01-15-AL	Alnova	1.5	3.0	10.0	50.0	6.0
AR-01-20-AL	Alnova	2.0	4.0	12.0	50.0	6.0
AR-01-30-AL	Alnova	3.0	6.0	12.0	50.0	6.0

# Tungsten Carbide Burs . HP

## 钨钢车针

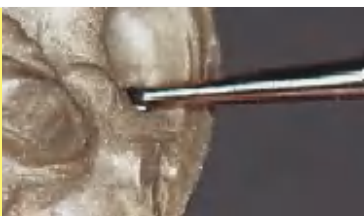

### Shape

- S1, ISO 001, Round
- S2, ISO 002, Inverted cone
- S21, S31, ISO 107, Cylinder
- S33, ISO 168, Taper
- S31R, ISO 137, Round, Cylinder

球型/Round	S1									
编号 No.	1005	1006	1007	1008	1009	1010	1012	1014	1016	1018
参考号 Ref.	HP1/4	HP1/2	HP1s	HP 1	HP 1b	HP 2	HP 3	HP 4	HP 5	HP 6

倒锥/Inv. Cone					S2					
1021	1023	1025	1027	1031	2008	2010	2012	2014	2016	
HP 7	HP 8	HP 9	HP 10	HP 12	HP 34	HP 35	HP 36	HP 37	HP 38	

圆柱/Cylinder				S21						
2018	2021	2023	21008	21009	21010	21012	21014	21016	21018	
HP 39	HP 40	HP 41	HP 55	HP 56	HP 57	HP 58	HP 59	HP 60	HP 61	

圆柱/Cylinder										S31
21021	21023	31008	31009	31010	31012	31014	31016	31018	31021	
HP 62	HP 63	HP 555	HP 556	HP 557	HP 558	HP 559	HP 560	HP 561	HP 562	

平锥/Taper							S33				S33L
31023	33008	33009	33010	33012	33016	33021	33023	33L009			
HP 563	HP 698	HP 699	HP 700	HP 701	HP 702	HP 703	HP 704	HP 699 L			

圆头柱 Round Cyl.				S31R			
33L010	33L012	33L016	33L021	31R010	31R012	31R014	
HP 700 L	HP 701 L	HP 702 L	HP 703 L	HP 1557	HP 1558	HP 1559	



# Tungsten Carbide Cutter . HP 钨钢磨头

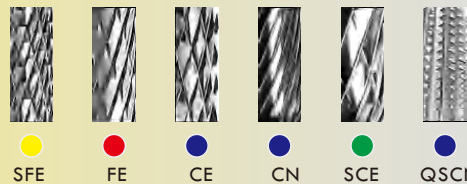
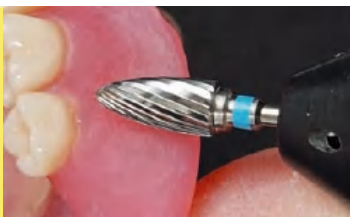

Super Fine  
Cross Cut  
(SFE)  
特细双纹  
黄圈  
ISO 500.104.110.

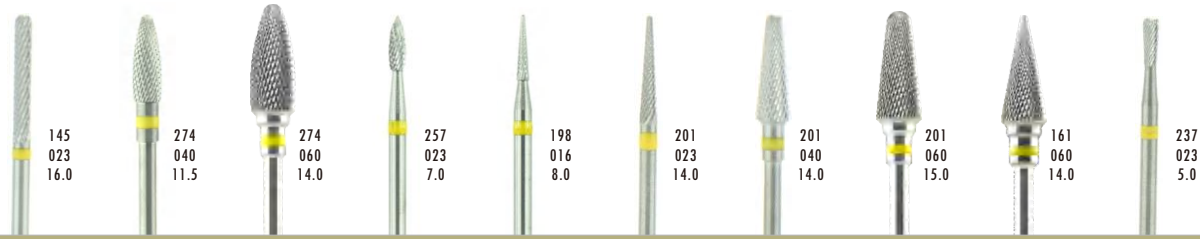

编号 No.	C023SFE	F040SFE	F060SFE	G023SFE	L016SFE	L023SFE	L040SFE	L060SFE	M060SFE	P023SFE
参考号 Ref.	0230.023	7230.040	5430.060	1030.023	1230.016	0130.023	5730.040	5530.060	5930.060	7730.023

Fine  
Cross Cut  
(FE)  
较细双纹  
红圈  
ISO 500.104.140.



编号 No.	Q023SFE	Q023SFE	C023FE	C060FE	F060FE	G040FE	G060FE	L016FE	L023FE
参考号 Ref.	0830.023	0430.023	0220.023	5820.060	5420.060	6120.040	5320.060	1220.016	0120.023

Medium  
Cross Cut  
(CE)  
标准双纹  
蓝圈  
ISO 500.104.190.



编号 No.	L040FE	L060FE	M060FE	P023FE	P060FE	Q023FE	A023CE	C023CE	C060CE
参考号 Ref.	5720.040	5520.060	5920.060	7720.023	5120.060	0420.023	0310.023	0210.023	5810.060



编号 No.	D023CE	D030CE	D040CE	D050CE	F040CE	F060CE	G023CE	G040CE	G060CE	L023CE
参考号 Ref.	7110.023	7110.030	7110.040	7110.050	7210.040	5410.060	1010.023	6110.040	5310.060	0110.023

								
201 040 14.0	201 060 15.0	167 023 14.50	167 040 14.5	161 060 15.0	237 023 5.0	237 060 11.0	292 023 16.0	001 030 3.0
<b>L040CE</b>	<b>L060CE</b>	<b>M023CE</b>	<b>M040CE</b>	<b>M060CE</b>	<b>P023CE</b>	<b>P060CE</b>	<b>Q023CE</b>	<b>D030CN</b>
5710.040	5510.060	—	—	5910.060	7710.023	5110.060	0410.023	7170.030

Medium Plain Cut (CN)  
标准单纹  
蓝圈  
ISO 500.104.175.

									
001 040 4.0	001 050 5.0	201 040 14.0	201 060 15.0	161 060 14.0	257 060 12.0	274 060 14.0	201 060 14.0	274 060 14.0	257 060 12.0
<b>D040CN</b>	<b>D050CN</b>	<b>L040CN</b>	<b>L060CN</b>	<b>M060CN</b>	<b>G060CN</b>	<b>F060CN</b>	<b>C060SCE</b>	<b>F060SCE</b>	<b>G060SCE</b>
7170.040	7170.050	5770.040	5570.060	5970.060	5370.060	5470.060	5850.060	5450.060	5350.060

Coarse Cross Cut (SCE)  
粗糙双纹  
绿圈  
ISO 500.104.220

							
201 040 14.0	201 060 14.0	237 060 11.0	263 070 14.0	274 060 15.0	201 023 14.5	200 045 13.0	263 060 12.0
<b>L040SCE</b>	<b>L060SCE</b>	<b>P060SCE</b>	<b>L070XCE</b>	<b>F060QSCN</b>	<b>L023QSCN</b>	<b>L045QSCN</b>	<b>LB060QSCN</b>
5750.040	5550.060	5150.060	6055.070	7275.060	0175.023	5675.045	5275.060

Super Coarse Cross Cut (XCE)  
特粗双纹  
黑圈  
ISO 500.104.223

Straight Edge with Spiral Cut (QSCN)  
直刃螺旋纹  
蓝圈  
ISO 500.104.176

							
141 023 8.0	194 023 8.0	201 040 14.0	289 023 8.0	274 040 11.5	274 060 15.0	201 023 14.5	201 040 13.0
<b>CS023GTi</b>	<b>LS023GTi</b>	<b>L040GTi</b>	<b>QS023GTi</b>	<b>F040QF</b>	<b>F060QF</b>	<b>L023QF</b>	<b>L040QF</b>
1726.023	0726.023	5726.040	0826.023	7224.040	5424.060	0124.023	5724.040

Straight Edge with Cross Cut (GTi)  
直刃双纹  
黑圈  
ISO 500.104.194

Spiral Cut Fine (QF)  
较细螺旋纹  
红圈  
ISO 500.104.134

						
141 023 8.0	274 060 14.0	198 023 8.0	201 040 14.0	289 023 8.0	118 060 3.5	467 023 9.0
<b>CS023QSF</b>	<b>F060QSF</b>	<b>LS023QSF</b>	<b>L040QSF</b>	<b>QS023QSF</b>	<b>ES801</b>	<b>AL023S4</b>
1725.023	5425.060	0725.023	5725.040	0825.023	118.060	467.023

Spiral Cut Extra Fine (QSF)  
特细螺旋纹  
黄圈  
ISO 500.104.137

## Tungsten Carbide Burs for Milling Machines

钨钢车针(精密研磨仪用)



Precisely match Various System  
Extra - long working life & high cutting capacity ;  
Used for trimming, polishing implant teeth shoulders ;  
Milling precious or Non-precious metals or Titanium .

Medium  
Cross Cut  
(CM, LM)  
标准双纹  
ISO 500.103.190

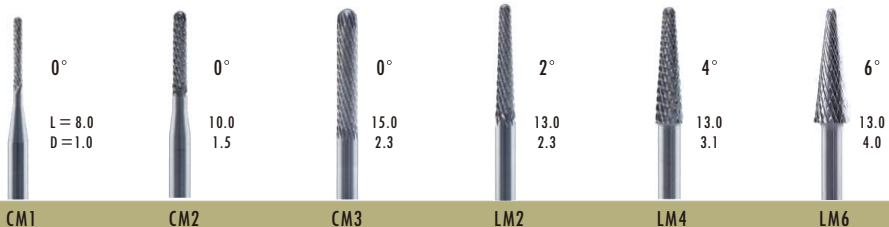

Fine  
Cross Cut  
(CF, LF)  
较细单纹  
ISO 500.103.135

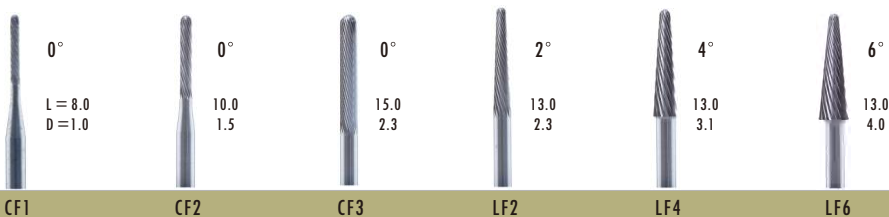

Coarse  
Cross Cut  
(CC, LC)  
粗糙双纹  
ISO 500.103.220

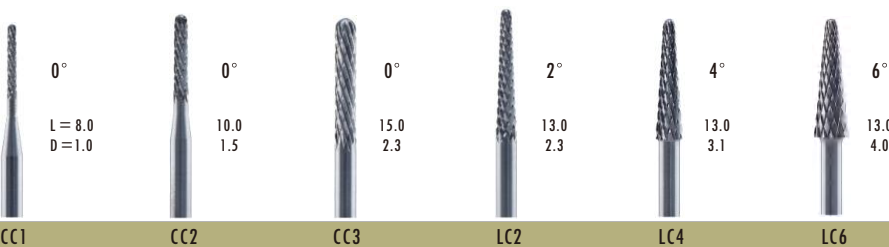

Max Mill  
(CW, LW)  
蜡型针  
ISO 500.103.217



# DuCoBur<sup>®</sup> 陶瓷结合剂金刚石磨头 (全瓷、全锆磨头)

Diamond Stones for Zirconia or AllCeramics (Ceramic Pregnant Diamond Grinding Burs)



Widely Used for Zirconia, Lithium Disilicate, Ceramics etc.  
COMFORTABLE at the minimal pressure;  
HEATLESS no need water cooling;  
MORE DURABLE under our suggested PRM

不产热、无需水冷 更耐磨、经济实惠 更锋利、手感好 不绷瓷、更轻松 型号齐、用途广、啥都磨得动

Medium Blue  
蓝色、中等粒度



Item No.

DC009

DC010

DC010B

DC011

DC014

DC015

DC016

DC017

DC003A

Size (mm)

4 x 4

4 x 7

4 x 11

3 x 7

2.5 x 4.5

3.5 x 10

2.5 x 7

3.5 x 11

6.5 x 2



DC001

DC002

DC002B

DC012

DC012B

DC013

DC004A

4 x 13

5 x 13

6.5 x 13

13 x 2

13 x 3.5

13 x 2

16 x 2/0.7



DC005A

DC004

DC005

DC006

DC007

16 x 2

22 x 2/0.7

22 x 2

22 x 4.5

15 x 3.5



Medium Black  
黑色、中等粒度



Item No.

DX001

DX002

DX002B

DX012

DX012B

DX013

DX004A

Size (mm)

4 x 13

5 x 13

6.5 x 13

13 x 2

13 x 3.5

13 x 2

16 x 2/0.7



DX005A

DX004

DX005

DX006

DX007

16 x 2

22 x 2/0.7

22 x 2

22 x 4.5

15 x 3.5



Medium Yellow

黄色、中等粒度

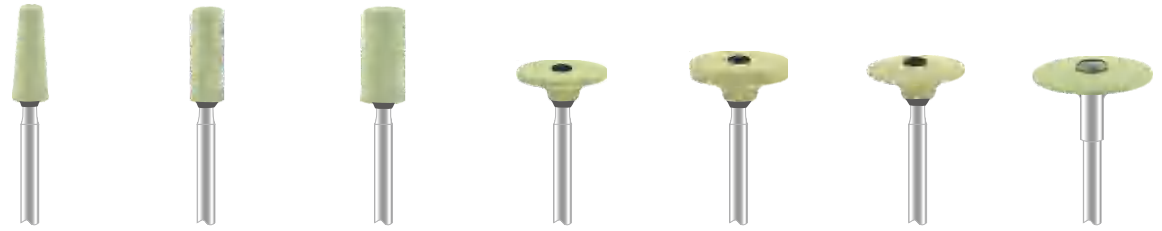

Item No.	DY001	DY002	DY002B	DY012	DY012B	DY013	DY004A
Size (mm)	4 x 13	5 x 13	6.5 x 13	13 x 2	13 x 3.5	13 x 2	16 x 2/0.7



Item No.	DY005A	DY004	DY005	DY006	DY007
Size (mm)	16 x 2	22 x 2/0.7	22 x 2	22 x 4.5	15 x 3.5

Medium Green

绿色、中等粒度



Item No.	DG009	DG010	DG010B	DG011	DG014	DG015	DG016	DG017	DG003A
Size (mm)	4 x 4	4 x 7	4 x 11	3 x 7	2.5 x 4.5	3.5 x 10	2.5 x 7	3.5 x 11	6.5 x 2

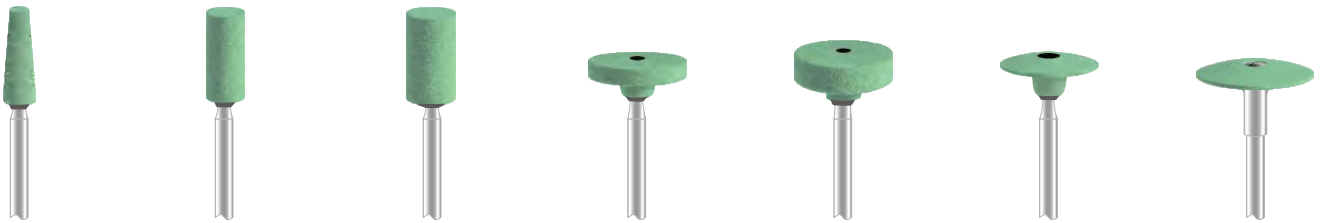

Item No.	DG001	DG002	DG002B	DG012	DG012B	DG013	DG004A
Size (mm)	4 x 13	5 x 13	6.5 x 13	13 x 2	13 x 3.5	13 x 2	16 x 2/0.7



Item No.	DG005A	DG004	DG005	DG006	DG007
Size (mm)	16 x 2	22 x 2/0.7	22 x 2	22 x 4.5	15 x 3.5

 Extra Fine  
 Yellow  
 Gold shank

Suitable to adjusting Lithium Disilicate, All Ceramics, Zirconia of Occlusal, Lingual, Edge, Intracoronal, Proximal etc. Dentists will feel very convenient if they can prepare a few pieces beside the chairs.

专门针对诊所的全瓷、玻璃陶瓷打磨抛光、氧化锆牙调咬合、发育沟、窝沟、边缘、内冠、邻面、舌侧等。黄色、特细粒度。粒度细、不绷瓷。

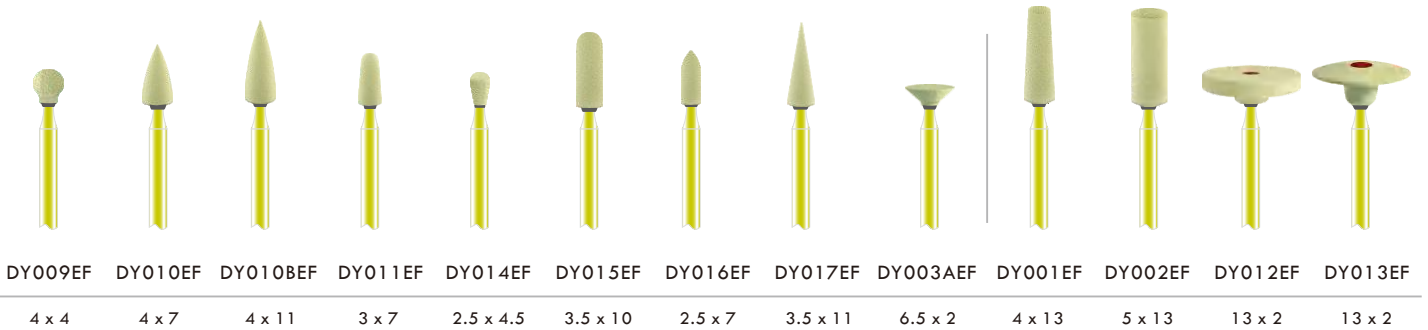





**DuCoBur** <sup>®</sup> 橡胶结合剂金刚石磨头  
 豆酷巴 (全瓷、全锆抛光磨头)

Diamond Polishers for Zirconia or AllCeramics  
( Rubber Pregnant Diamond Polishing Burs )



Widely Used for Zirconia, Lithium Disilicate, Ceramics etc.

COMFORTABLE at the minimal pressure;  
HEATLESS no need water cooling ;  
MORE DURABLE under our suggested PRM

不产热、无需水冷  更耐磨、经济实惠  手感好、很服帖  抛就亮、更轻松  型号齐、用途广、啥都抛得亮

 Super Coarse  
 Black  
 黑色、特粗粒度



Item No.

D1S

D2AS

D2S

D3S

D3BS

Size (mm)

26 x 2

20 x 2

26 x 2

22 x 3

26 x 2

 Coarse  
 Green  
 绿色、粗糙粒度



Item No.

D1C

D2AC

D2C

D3C

D3BC

Size (mm)

26 x 2

20 x 2

26 x 2

22 x 3

26 x 2



Medium Blue  
蓝色、中等粒度



Item No.	D1M	D2AM	D2M	D3M	D3BM
Size (mm)	26 x 2	20 x 2	26 x 2	22 x 3	26 x 2



D201M	D203M	D205M	D205BM	D207M	D13M	D17M	D26M
5 x 16	6 x 16	12 x 2	12 x 4	12 x 2.5	14 x 2	17 x 2.2	26 x 2.2

Fine Red  
红色、较细粒度



Item No.	D1F	D2AF	D2F	D3F	D3BF
Size (mm)	26 x 2	20 x 2	26 x 2	22 x 3	26 x 2



D201F	D203F	D205F	D205BF	D207F	D13F	D17F	D26F
5 x 16	6 x 16	12 x 2	12 x 4	12 x 2.5	14 x 2	17 x 2.2	26 x 2.2

Extra Fine  
Yellow  
黄色、特细粒度



Item No.	D1EF	D2AEF	D2EF	D3EF	D3BEF
----------	------	-------	------	------	-------

Size (mm)	26 x 2	20 x 2	26 x 2	22 x 3	26 x 2
-----------	--------	--------	--------	--------	--------

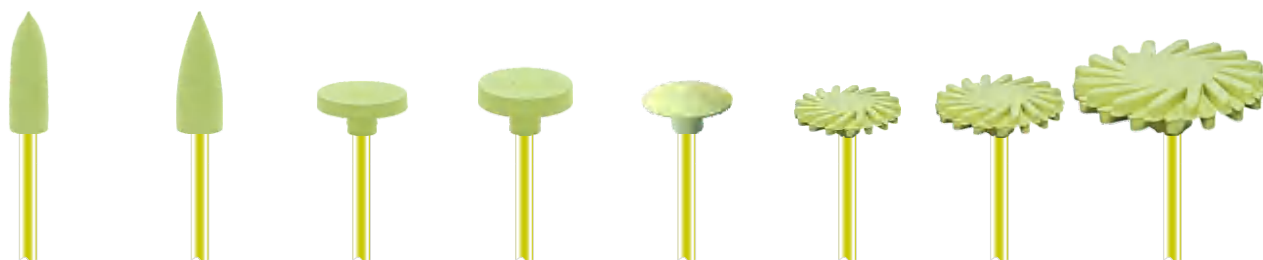

D201EF	D203EF	D205EF	D205BEF	D207EF	D13EF	D17EF	D26EF
--------	--------	--------	---------	--------	-------	-------	-------

5 x 16	6 x 16	12 x 2	12 x 4	12 x 2.5	14 x 2	17 x 2.2	26 x 2.2
--------	--------	--------	--------	----------	--------	----------	----------

Ultra Fine  
Grey  
灰白色、特细粒度



Item No.	D1UF	D2AUF	D2UF	D3UF	D3BUF
----------	------	-------	------	------	-------

Size (mm)	26 x 2	20 x 2	26 x 2	22 x 3	26 x 2
-----------	--------	--------	--------	--------	--------



D201UF	D203UF	D205UF	D205BUF	D207UF	D13UF	D17UF	D26UF
--------	--------	--------	---------	--------	-------	-------	-------

5 x 16	6 x 16	12 x 2	12 x 4	12 x 2.5	14 x 2	17 x 2.2	26 x 2.2
--------	--------	--------	--------	----------	--------	----------	----------

**Silicon Rubber Wheels ,  
Points & Burs  
For Polish Ceramics  
胶轮、胶粒、硅胶磨头  
(烤瓷牙抛光)**

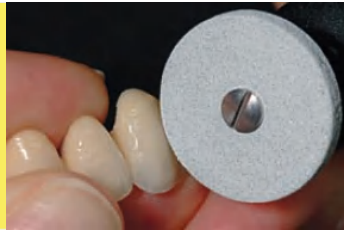

White, Coarse , to adjust and remove Porcelain  
白色, 粗糙, 用于烤瓷工件的修整。  
Pink, Medium , to Smooth or polish Porcelain,  
粉色, 中等, 用于烤瓷毛面平整和预抛光。  
Blue, Fine , to high-lustre polishing Porcelain,  
蓝色, 较细, 用于烤瓷工件的细抛光。

Coarse  
White  
白色、粗糙



100

Item No.



C 104 C



C 107 C



C 101 C



C203C



C201C



C205C



C207C

Size (mm)

22x 3

22 x 3

6 x 22

6 x 13

5 x 13

12 x 2

13 x 2

Medium  
Pink  
粉色、中等粒度



100

Item No.



C 104 M



C 107 M



C 101 M



C203M



C201M



C205M



C207M

Size (mm)

22x 3

22 x 3

6 x 22

6 x 13

5 x 13

12 x 2

13 x 2

Fine  
Blue  
蓝色、较细



100

Item No.



C 104 F



C 107 F



C 101 F



C203F



C201F



C205F



C207F

Size (mm)

22x 3

22 x 3

6 x 22

6 x 13

5 x 13

12 x 2

13 x 2

**Rubber Wheels , Points & Burs  
For Polish Metal or Alloy  
胶轮、胶粒、橡胶磨头  
(金属、合金抛光)**



Black, Coarse , to adjust Cobalt-Chromium  
Alloy and hard metal  
黑色, 粗糙, 用于磨削钴铬合金和硬金属。  
Brown, Medium , to remove metal and  
semi-precious metal  
棕色, 中等, 用于烤瓷毛面平整和预抛光。  
Green, Fine , to fast smooth scratch or polish metal,  
绿色, 较细, 用于快速去除划痕和抛光金属。

Coarse  
Black  
黑色、较粗



100

Item No.



A102 C



A103 C



A104 C



A203 C



A201 C



A206 C



A207 C

Size (mm)

22x 3

22 x 3

6 x 22

4 x 12

5 x 13

12 x 2

13 x 2

Medium Brown  
棕色、中等粒度  
100



Item No.	A102 M	A103 M	A104 M	A203M	A201M	A206M	A207M
Size (mm)	22x 3	22 x 3	6 x 22	4 x 12	5 x 13	12 x 2	13 x 2

Fine Green  
绿色、较细  
100



Item No.	A102 F	A103 F	A104 F	A203F	A201F	A206F	A207F
Size (mm)	22x 3	22 x 3	6 x 22	4 x 12	5 x 13	12 x 2	13 x 2

Silicon Polishing Burs  
For Composites, Resins  
硅胶磨头  
(树脂胶托抛光)



Green, Coarse, to reduce, finish Acrylic, Resin.  
绿色, 粗糙, 用于修整和成型树脂胶托。  
Gray, Medium, to Smooth Acrylic, Resin.  
灰黑色, 中等, 用于平整和预抛光树脂胶托。  
Yellow, Fine, to final polish Acrylic, Resin.  
黄色, 较细, 用于树脂胶托的细抛光。

Coarse Green  
绿色、粗糙  
100



Item No.	Rh 101 C	Rh 103 C	Rh 106 C	R103C	R106C	R209C
Size (mm)	13 x 20	10x 24	10 x 20	10x 24	10 x 20	6 x 13

Medium Gray  
灰黑、中等粒度  
100



Item No.	Rh 101 M	Rh 103 M	Rh 106 M	R103M	R106M	R209M
Size (mm)	13 x 20	10x 24	10 x 20	10x 24	10 x 20	6 x 13

Fine Yellow  
黄色、较细  
100



Item No.	Rh 101 F	Rh 103 F	Rh 106 F	R103F	R106F	R209F	R202F
Size (mm)	13 x 20	10x 24	10 x 20	10x 24	10 x 20	6 x 13	4 x 12

Green Stones  
Contour Ceramic

绿车石  
调烤瓷

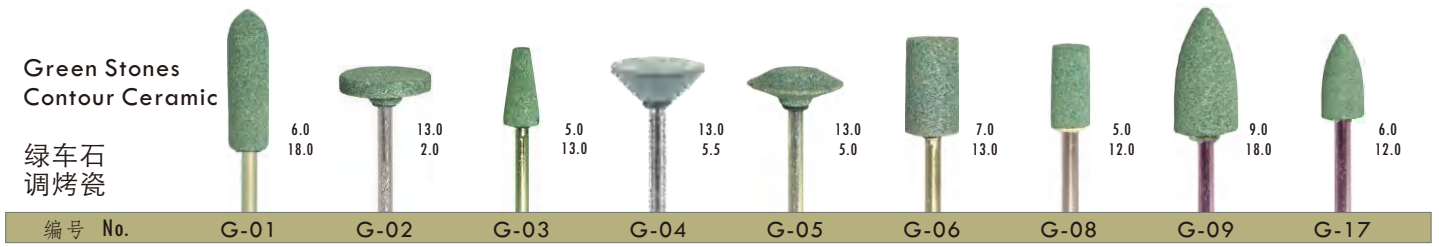

Pink Stones  
for Metal  
粉车石  
调金属,合金



White Stone  
for Metal  
Composite,  
白车石  
调金属,树脂

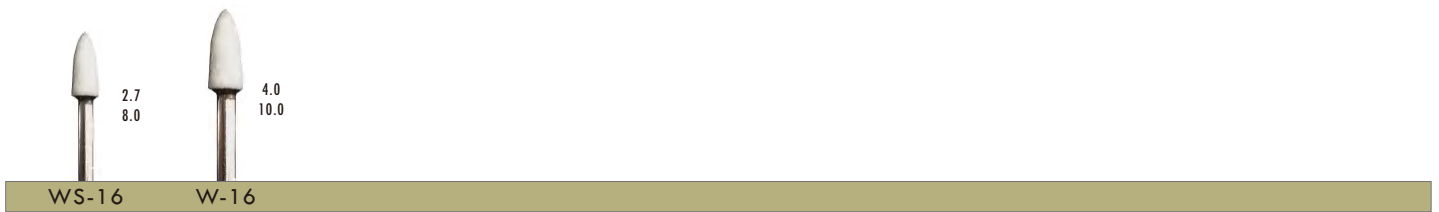
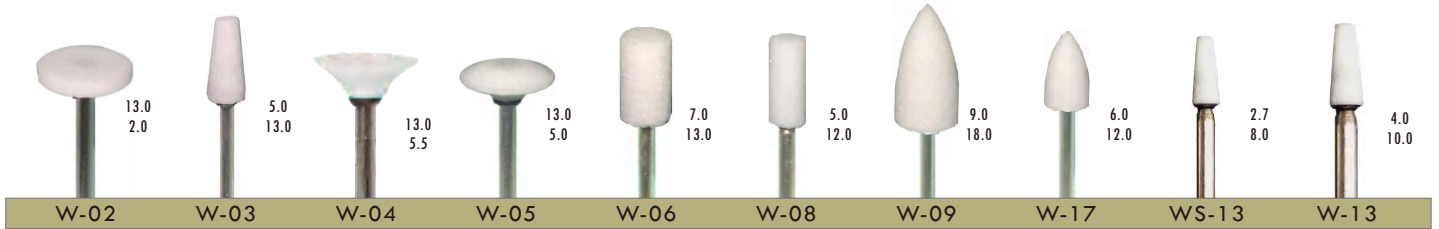
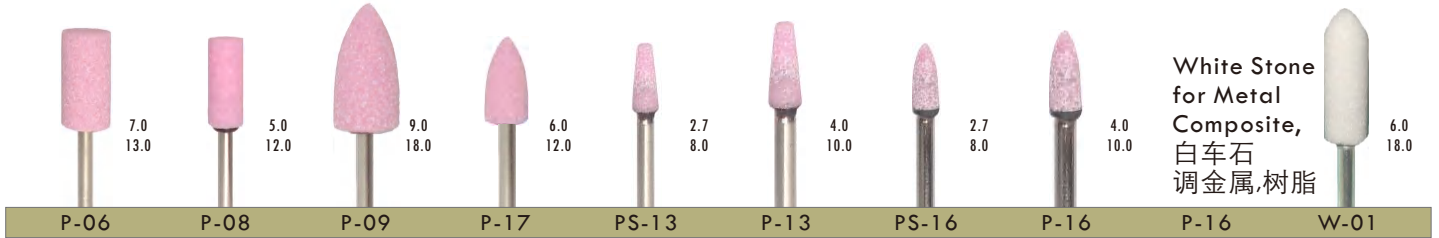

Mounted Sandpaper 砂纸棒









# Polishing Brushes 抛光刷

				
百洁布 暗红,中粗	百洁布 红,硬	百洁布 棕,中粗	百洁布 紫,软	百洁布 普通
<b>01MT25</b> Red.Soft	<b>01Mp25</b> Red.coarse	<b>01My25</b> Brown. Medium	<b>01Ms25</b> Purple.fine	<b>01M22</b> Blue

						
碳化硅 磨料丝	氧化铝 磨料丝	曲钢丝	曲铜丝	黑猪鬃	灰马毛	灰羊毛
<b>01SiC22</b> Silicon Carbide	<b>01Al22</b> Al. Oxide	<b>01A22</b> Crimped steel wire	<b>01B22</b> Crimped brass wire	<b>01D22</b> Chungking Bristle	<b>01E22</b> Grey Pony hair	<b>01F22</b> Grey goat hair

					
白羊毛	灰羊毛 +超纤皮	黑猪鬃 19mm	灰马毛	灰羊毛	白羊毛
<b>01G22</b> White goat hair	<b>01Fr22</b> Goat hair / chamois	<b>01D19</b> Chungking Bristle	<b>01E19</b> Grey Pony hair	<b>01F19</b> Grey goat hair	<b>01G19</b> White goat hair

							
黄棉布	白棉布	橘红 羊皮	双面绒 羊皮	咖啡 超纤	白厚 超纤	羊绒	白棉线
<b>01P22</b> Yellow cloth	<b>01Q22</b> White cloth	<b>01R22</b> Chamois leather	<b>01Ry22</b> Sheep Leather	<b>01R22.2</b> Brown Micro-Fiber	<b>01Ry22.2</b> White Microfiber	<b>01S22</b> Cashmere	<b>01T22</b> Cotton yarn

						
黑猪鬃	灰马毛	白羊毛	曲钢丝	曲铜丝	黑猪鬃	灰羊毛
<b>02D22</b> Chungking Bristle	<b>02E22</b> Pony hair	<b>02G22</b> White goat hair	<b>04A12</b> Steel	<b>04B12</b> Brass	<b>04D12</b> Bristle	<b>04F12</b> Goat Hair

						
碳化硅 磨料丝	氧化铝 磨料丝	曲钢丝	曲铜丝	黑猪鬃	灰马毛	灰羊毛
<b>05SiC05</b> SiC	<b>05Al05</b> Al. Oxide	<b>05A05</b> Steel	<b>05B05</b> Brass	<b>05D05</b> Bristle	<b>05E05</b> Pony Hair	<b>05F05</b> Goat Hair



Polishing brush & Wheel  
in Bristle, Cotton Cloth  
抛光刷



These brushes are made of bristle hair or White, yellow pure cotton cloth, assembled on polishing latch to finish or polish Plaster Moulds, Acrylic 台式抛光机配用的抛光刷/布轮,用于抛光塑料,树脂,模型等。

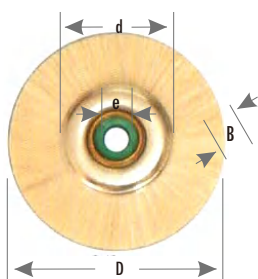
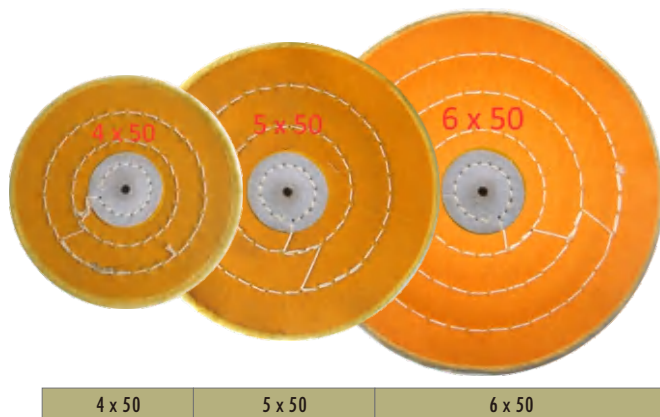
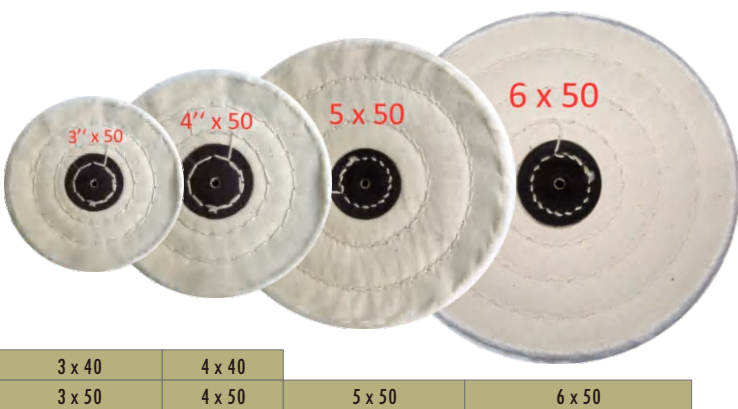
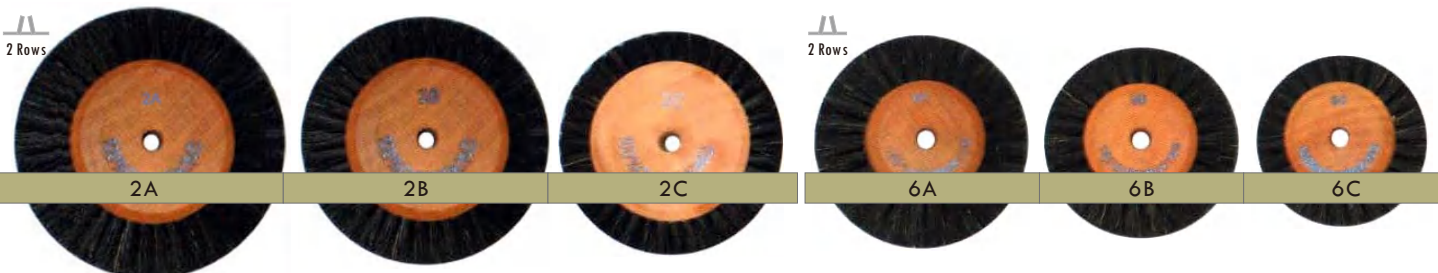
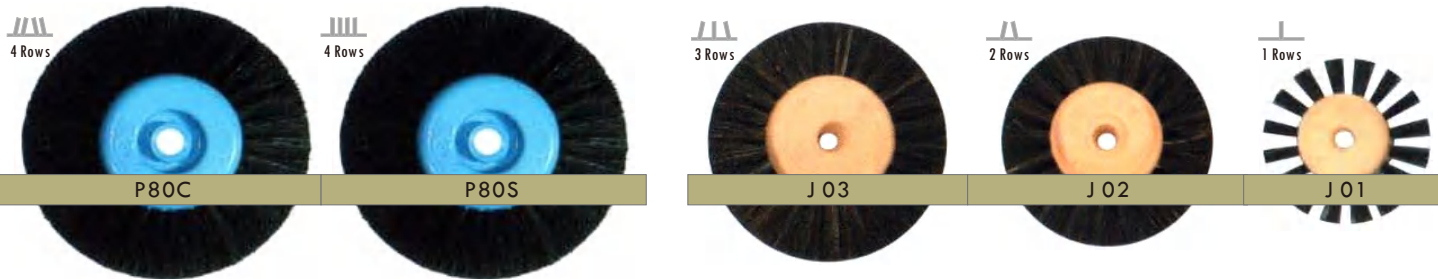

Item	2A	2B	2C	6A	6B	6C	J03	J02	J01	P80	03B48
D	79	73	68	64	60	54	70	58	51	80	48
d	48	48	48	35	35	35	35	30	25	40	25
e	6.5	6.5	6.5	6.5	6.5	6.5	8.5/5	8/5	7/5	6.5	6.35
B	16	16	16	16	16	16	24	16.5	15	36	9
Rows	2	2	2	2	2	2	3	2	1	4	1

Converging

Straight

## Felt Bobs & Burs 毛毡磨头



<b>03N25</b>	<b>03Ns25</b>	<b>3P</b>	<b>2P</b>	<b>1P</b>	<b>1R</b>
25 x 5 mm, 硬质	25 x 5 mm, 软质	15 x 25 mm	20 x 40 mm	22 x 50 mm	22 x 50 mm

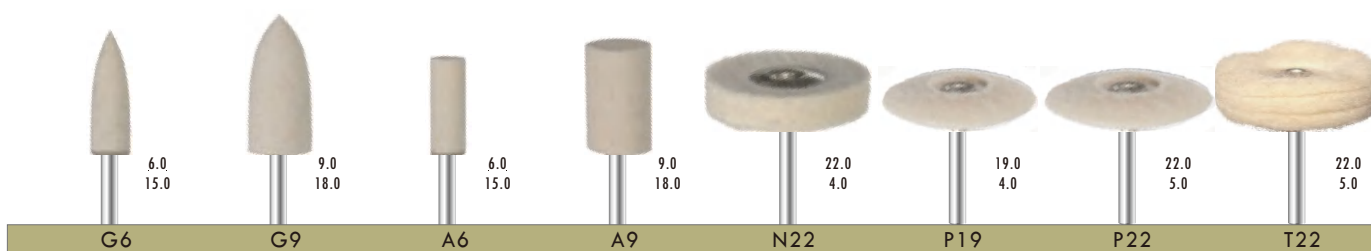

<b>G6</b>	<b>G9</b>	<b>A6</b>	<b>A9</b>	<b>N22</b>	<b>P19</b>	<b>P22</b>	<b>T22</b>
6.0 15.0	9.0 18.0	6.0 15.0	9.0 18.0	22.0 4.0	19.0 4.0	22.0 5.0	22.0 5.0

## Mandrels Stainless Reinforced 不锈钢夹针

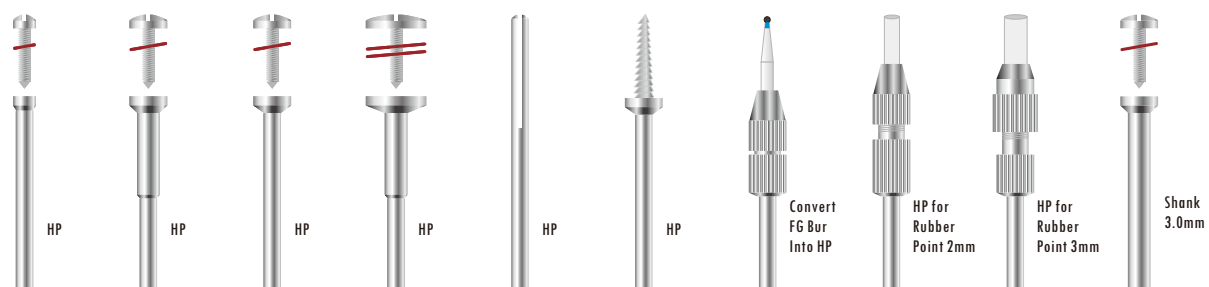

编号 No.	<b>32HS</b>	<b>51HS</b>	<b>52HS</b>	<b>81HS</b>	<b>25HS</b>	<b>53HS</b>	<b>55HS</b>	<b>D20HS</b>	<b>D30HS</b>	<b>52D</b>
Head size	3.0mm	5.0mm	5.0mm	8.0mm	2.5mm	5.0mm	5.0mm	5.0mm	6.0mm	5.0mm

## Mandrels Steel 普通夹针

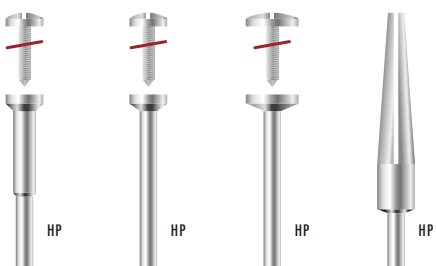

编号 No.	<b>51H</b>	<b>52H</b>	<b>72H</b>	<b>54H</b>
Head size	5.0mm	5.0mm	7.0mm	5.0mm

## Hard Z Cutter 硬锆磨头

Made of Nano-grade Zirconia, used to grinding, finishing or polishing Ceramics and Acrylic, Resin, Zirconia etc. Also applied to Soft materials such as wood, Ceramic or stones etc

用于打磨,成型,抛光烤瓷,树脂,氧化锆(烧结前)。特殊的纳米级氧化锆胚体制而成。

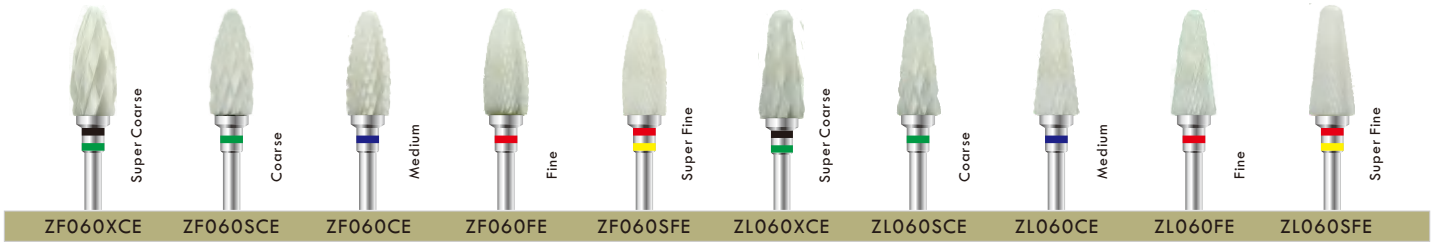
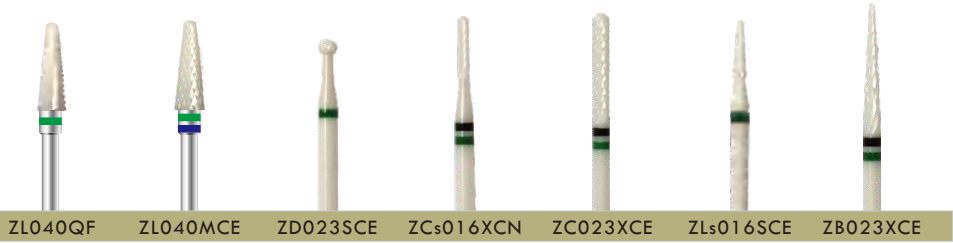

## Sharpening Stones 磨刀石

Adjust to minimum speed;  
Touch the stones softly.  
Using water will be better

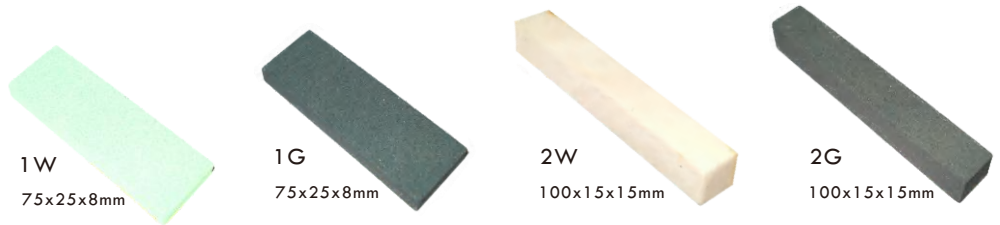

## Cleaning Brushes By Hand 清洁刷(手用)



## Stainless Steel Disc 不锈钢小锯片

for Soft Plastic, Acrylic, Wood etc.



## Stone Disc 刚玉车片

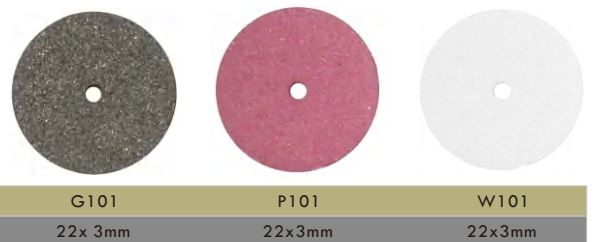

3Z09.1

Zirconia Luster Polishing Kit  
氧化锆抛光套装

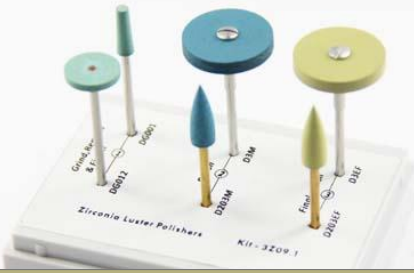

- + 2 pieces of Diamond Stones DG001 , DG012
- + 2 pieces of Diamond Polishers, Blue, D203M, D3M
- + 2 pieces of Diamond Polishers, Yellow, D203EF, D3EF

3Z00.2

Grinding and polishing Kit of Zirconia  
氧化锆打磨抛光套装

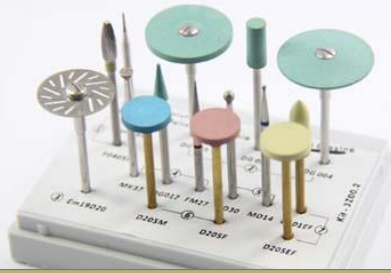

- + 2 pieces of Tungsten carbide Burs HP 699, F040SFE
- + 1 set of Diamond Disc Em19D20 Mounted
- + 4 pieces of HP Diamond Burs: MK37, FM27, FD30, MD14
- + 4 pieces of Diamond Stones: DG017, DG002, DG004, DG005
- + 4 pieces of Diamond Polishers: D205M, D205F, D205EF, D201EF .

3Z00.3

Grinding and Polishing Kit for Zirconia  
氧化锆打磨抛光套装

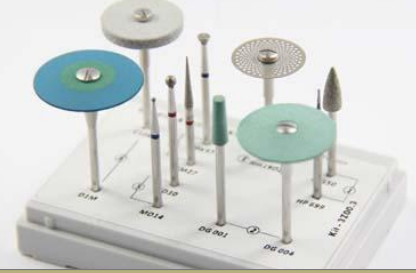

- + 1 piece HP Tungsten Carbide Burs HP 699
- + 5 pieces Diamond Burs: MG50, MD14, FD30, FM27, MK37 ;
- + 1 set of Diamond Disc Hm19D20 Mounted
- + 1 piece of Diamond Polisher D1M
- + 1 set of Silicon polisher C104C Mounted

3L04.2

Grinding and Polishing Kit for Lithium Disilicate  
玻璃陶瓷打磨抛光套装



- + 1 set of Diamond Disc Hm19D20, Mounted ,
- + 3 pieces of Diamond Stones DG017 , DG004, DY001EF
- + 3 pieces of HP Diamond Burs MD10, MB12, MR23
- + 3 piece of Diamond Polisher D1M, D13F, D13UF
- + 1 piece of Silicon Polisher C205C

3L04.3

Grinding and Polishing Kit for Lithium Disilicate  
玻璃陶瓷打磨抛光套装

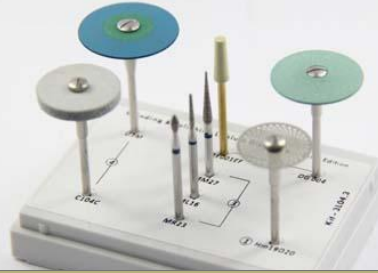

- + 1 set of Diamond Disc Hm19D20, Mounted ,
- + 2 pieces of Diamond Stones DG004, DY001EF ,
- + 3 pieces of HP Diamond Burs MR23, ML16, MM27 ,
- + 1 piece of Diamond Polisher D1M
- + 1 piece of Silicon Polisher C205C

3MC02.3

Adjusting and Polishing Kit for Ceramics  
烤瓷工件打磨抛光套装

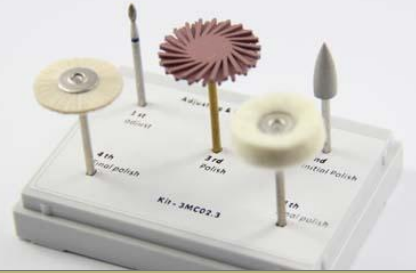

- + 1 piece of HP Diamond Burs MR23
- + 1 piece of HP Silicon Polisher C203C
- + 1 piece of Diamond Polisher D26f
- + 2 pieces of Polishing Brushes 01G22 , N22

3MR09.1

Adjust & Polish Invisible Braces  
隐形牙套调整抛光套装



- + 1 piece of Tungsten Carbide Burs AL02354
- + 1 set of Diamond Disc C19D20, Mounted
- + 2 pieces of Polishing Brushes 01Ms25 , 01S22



### 3A00.1

Popular HP Kit for grinding or polish Metal or Alloy  
常用打磨抛光金属、合金的套装



- \* Universally grind, remove, polish and finish of Alloy, metal, Jewellery, stones etc.  
It widely applied to Laboratory, DIY or Hobbies.
- + 5 pieces of HP sintered diamond burs ,
- + 4 pieces of HP Tungsten Carbide Cutters
- + 10 pieces of HP Tungsten Carbide burs
- + 4 pieces of White stones
- + 2 pieces of Pink stones
- + 10 pieces of HP Silicon Polishers
- + 3 pieces of Rubber wheel mounted
- + 1 piece of Woolen Felt wheel mounted ,
- + 5 pieces of HP Polishing brushes

### 3MC00.1

Popular HP Kit for grinding or polish Ceramics / Porcelain  
常用打磨抛光陶瓷的套装



- \* Universally grind, remove, polish and finish of Ceramics or Porcelains etc.  
It widely applied to Laboratory, DIY or Hobbies.
- + 10 pieces of HP Diamond burs ,
- + 4 pieces of Diamond Discs mounted
- + 6 pieces of HP Green Stones
- + 3 pieces of Silicon Rubber wheel mounted
- + 8 pieces of Silicon Rubber Polishers
- + 4 pieces of Polishing brushes

### 3LR00.1

Popular HP Kit for grinding or polish Acrylic, Resin  
常用打磨抛光树脂胶托的套装



- \* Universally grind, remove, polish and finish of Acrylic, Resin etc.  
It widely applied to Laboratory, DIY or Hobbies.
- + 2 pieces of HP Tungsten Carbide Cutters
- + 3 pieces of HP Silicon rubber Polishers
- + 10 pieces of Polishing brushes
- + 3 pieces of Woolen Felt polishing brushes

### 3Z00.1

Popular HP Kit for grinding or polish Zirconia, Lithium Disilicate  
常用打磨抛光氧化锆、玻璃陶瓷的套装



- \* Universally grind, polish and finish of Zirconia and Lithium Disilicate etc.  
It widely applied to Laboratory, DIY or Hobbies.
- + 4 pieces of HP Diamond Burs
- + 2 pieces of Diamond Discs Mounted
- + 6 pieces of Diamond Stones
- + 4 pieces of Diamond polishing wheels
- + 2 pieces of Diamond polishing burs
- + 5 pieces of Diamond Twist polishers
- + 1 pieces of Polishing brush .

### ZS100

Hot HP Mounted stones mixed  
车石套装,常用。



- \* 100 Pcs, Hot Mounted stones in Green, Pink, White , applied to Alloy, metal, ceramics, Jewellery, stones, hard wood etc.
- + 30 pieces of HP Green Stones
- + 30 pieces of HP Pink Stones
- + 30 pieces of White Stones
- + 10 pieces of Brown Stones

### ZD 101

Popular HP diamond burs KIT  
常用金刚石磨头套装

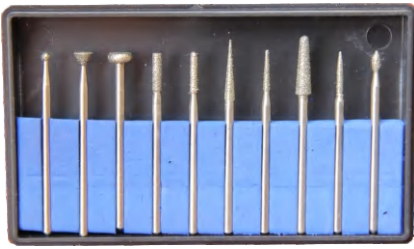

MD23, MK47, MJ60, MA23, MC18, MM27, MB21, ML40, MG16, MR23

10 Hot Spec. of HP Diamond, universally grind, remove, polish and finish of Alloy, metal, Jewellery, stones etc. It widely applied to Laboratory, DIY or Hobbies.

用途: 选取10支最常用的金刚石磨头, 形状全, 大小适中, 可以用来处理陶瓷工件。

### ZD 101F

Popular HP diamond burs KIT  
常用金刚石磨头套装

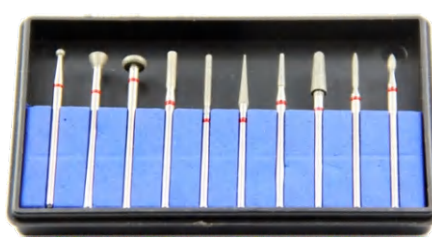

FD23, FK47, FJ60, FA23, FC18, FM27, FB21, FL40, FG16, FR23

10 Hot Spec. of HP Diamond of Fine grit, universally grind, remove, polish and finish of Zirconia, Lithium Disilicate, Porcelain etc. It widely applied to Laboratory, DIY or Hobbies.

用途: 选取10支最常用的金刚石磨头, 形状全, 大小适中, 可以用来处理氧化锆、玻璃陶瓷、烤瓷等工件。

### ZD 102

Small & Tiny Cut, HP diamond burs KIT  
金刚石磨头, 小号套装

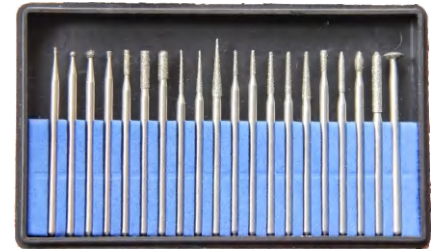

MD10, MD14, MD23, MK16, MA16, MA23, MC25, MM12, MM18, MM27, MB12, MB16, MB21, ML16, ML23, MN18, MG16, MR23, MQ23, MU50.

20 Spec. small or sharp burs. To create tiny hole, slim curves or tiny, deep grind smartly. Used to Alloy, metal, ceramics, Jewellery, stones, hard wood etc. It widely applied to Laboratory, DIY or Hobbies.

用途: 20支金刚石磨头, 用来开小洞, 细边, 细槽, 或者小的磨削。很轻巧, 灵活。适用于各种金属, 合金, 陶瓷, 珠宝, 宝石, 木头等。

### ZD 103

Fast Trimming, HP diamond burs KIT  
金刚石磨头套装, 快速磨削



CQ23, CL40, SD35, SA50, SC40, SP70, SG50, SV70, SV60, SF60

20 Spec. HP Diamond for fast trimming, Grinding of Plastic, Jewellery, stones, Hard wood, etc. Save time when removing and work efficiently. 用途: 10支常用的金刚石磨头, 头部相对比较大, 可以快速磨削塑料, 木头, 陶瓷和石头等等, 适用于牙科, 珠宝加工和DIY爱好者。

### ZD 104

Hot Fully-Sintered diamond KITS  
全砂烧结磨头套装, 常用



C 050S, F050S, L050S, B050C, A037, G050, C037F, F050F, M050EF, G050EF

10 spec. Hot Fully-sintered Diamond HP burs, universal grind, remove, polish and finish of Alloy, metal, Jewellery, stones etc. It widely applied to Lab, DIY or Hobbies.

用途: 10个常用全砂烧结磨头, 5种不同粗细。广泛适用于研磨, 抛光金属, 合金, 珠宝, 宝石。经久耐用, 方便实惠。

### ZD 105

Fast Trimming Fully-Sintered diamond KIT  
全砂烧结磨头套装, 大磨削



K080S, K100S, J100S, C070S, M070S, B070S, L070S, G060S, F070S, R070S

If workpieces are extremely hard and waste too much time when grinding, this fast trimming kit may help to work efficiently. Applied to Alloy, metal, Jewellery, stones, hard wood, etc.

用途: 10个大头的全砂烧结磨头, 用于粗磨, 去块, 效率高, 经济实惠。

### ZT 101

Popular HP Tungsten carbide burs KIT  
常用低速钨钢针



HP 1/4, HP 1/2, HP 1, HP 2, HP 3, HP 4, HP 5, HP 8, HP 34, HP 36, HP 38, HP 41, HP 556, HP 557, HP 560, HP 563, HP 699, HP 701, HP 702, HP 704

20 Spec. HP Tungsten Carbide burs are used to create tiny hole, slim curves or tiny, deep grind very smartly. It is applied to Alloy, metal, ceramics, Jewellery, stones, hard wood etc.

用途: 20个型号钨钢车针, 用于雕牙花, 钻小孔, 洞, 开细槽, 细线等, 金属, 合金, 宝石, 坚木都可以用。

### ZT 102

Hot Tungsten carbide cutters Kit  
钨钢磨头套装, 常用



D050SP, L040SC, L060SC, F060SC, B023SC, L023SC, L040FC, C023FC, L040EFC, F060CC

10 spec. Tungsten carbide Cutter, universal grind, remove, polish and finish of Acrylic, Resin, stones, soft metal or wood.

用途: 10个常用钨钢磨头, 形状全, 大小适中。主要用来研磨, 抛光塑料, 树脂, 软金属, 石头等, 方便实惠。

### ZF 101

Acrylic Polishing Kit  
树脂托抛光套装



F060SC, L040SC, U12 x 2, U13 x 2, U16 x 2

Simple and straight way to adjust Acrylic without the problem associated with pumice.

用途: 2个型号的钨钢磨头快速磨削, 三个不同粒度的硅胶磨头依次进行抛光。

### ZA 101

Non-precise metal, Alloy Adjust and polish  
非贵金属, 铬钴调整与抛光



W-01, W-09, W-08, W-16, W-03, W-06  
A201C, A203C, A206C, A201F, A203F

To adjust and polish Cobalt-chromium, nickel chromium Alloy. White stones for adjusting or grinding, Rubber burs for polishing.

用途: 试用于铬钴、镍铬合金等非贵金属的研磨和抛光  
6支白车石用来研磨和调整, 5支硅胶磨头用来抛光。

### ZP 100

Sandpaper Polishing burs Kit  
砂纸棒套装



240#, 400#, 600#, 800#, 1000#, 1500#, 2000#, 2500#, 3000#, 5000#

10 different Grit Sandpaper burs are used for polishing Alloy, metal, Jewellery stones, hard woods etc. Working step by step, mirror surface in coming soon, water cooling or dry are acceptable.

用途: 10个不同粒度的砂纸棒, 从240目到5000目不等, 请根据需要, 选取合适的粒度, 耐心细致的使用。

### Z 2001

Popular Felt Polishing bur Kit  
毛毡抛光磨头套装



12 pieces of High quality Felt polishing burs are widely used to mould, Alloy, metal, Jewellery, stones, Hard woods etc.

12 pieces of High quality Felt polishing burs are widely used to mould, Alloy, metal, Jewellery, stones, Hard woods etc.

用途: 12支常用的毛毡磨头, 广泛适用于各种模具, 金属, 陶瓷, 珠宝, 宝石和木头等。



# Samples Collection

## 样品册

- Flip-Cart Plastic Pages ;
- Smart, Easily fill all burs ;
- Economic and Recyclable ;
- Nice-looking for showing to Customers;
- Convenient to take to anywhere .



### No. 171B5

Empty Collection Wallet  
样品本(不带车针)



4 Colors Available ,  
100 holes per page,  
5 pages per set,  
Smart to HP Burs



### No. 1704D

Sintered Diamond Burs Collection  
全砂烧结磨头样品本



115 specifications ,  
Fully Sintered Diamond,  
HP shanks



### No. 1705D

HP Diamond Burs, Mounted Stones  
金刚石磨头, 车石样品本



More than 100 specifications ,  
Electroplating Diamond burs  
HP Shanks



### No. 1707T

Tungsten carbide Burs Collection  
高品质钨钢磨头样品本



More than 100 specifications ,  
High Quality TC burs,  
HP Shanks



### No. 1708P

Polishing Burs, Mandrels Collection  
抛光磨头, 夹针样品本



More than 100 specifications ,  
Silicon, Rubber, Diamond burs  
HP Shanks



## 隐形义齿胶

### FlexSoft Partial Dentures



The alternative to conventional Partial Dentures ;  
Flexible . Soft. Easy-to-finish. Easy-to-polish  
弹性好, 易成型, 易抛亮, 美观大方。



编号 No.	规格 Spec.
D2	Crystal ; 18 gs
C1	Ligth Pink ; 9 gs
C2	Ligth Pink ; 18 gs
B1	Standard Pink ; 9 gs
B2	Standard Pink ; 18 gs
A1	Deep Pink ; 9 gs
A2	Deep Pink ; 18 gs
For bulk pak of 1 kilo.	
C3	Ligth Pink ; 1000 gs
B3	Standard Pink ; 1000 gs
A3	Deep Pink ; 1000 gs



Crystal (D)  
(透明)



Light pink (C)  
(浅粉红)



Standard pink (B)  
(粉红)



Deep pink (A)  
(深粉红)



### Instructions for Use

Suitable for: Partial and complete dentures, occlusal splints and nightguards.

Not Suitable for: Small unilateral restorations.

Warnings: Use eye protection and heat-resistant gloves when injecting.

Use proper ventilation, vacuum system and masks when grinding prosthodontic resins.

Precautions: Cartridge must be injected within 1 hour of opening the foil pouch.

#### I. PREPARING THE MASTER MODEL FOR DUPLICATION

All undercuts that will affect the path of insertion should be blocked-out with wax prior to duplication. Do not relieve necklines of teeth or areas desirable for retention. For free-end saddles, it is not necessary to remove the distal undercut of the last natural tooth, unless the area is too deep. For free-end saddle cases where anterior teeth are also being replaced, undercuts in the anterior should also be blocked out.

#### II. SET-UP

Duplicate blocked-out master model. Articulate the duplicate model and the master model (you will need the master model articulated at finishing steps to check occlusion). Set up the case on the duplicate model using only wax (no base plate).

Allow 1 mm of thickness under the teeth to flow to the labial side and into the retention diatorics in the teeth. Use a small round carbide bur to create mechanical retention in the teeth, from mesial to distal and connected to the center diatoric hole.

#### III. WAXING

Important: Wax the case with anatomical features to reduce grinding during the finishing stage.

Recommended thickness of wax-up:

1. Palatal thickness 1.2 - 1.5 mm
2. Buccal & Labial Flange 1.2 - 2.0 mm
3. Clasps 1.0 - 1.5 mm
4. Lingual Flange 1.2 - 2.0 mm
5. Lingual Major Connector (Mandibular) 1.7 - 2.0 mm

#### IV. INVESTING AND SPRUING

Invest the case in the center of the flask, aiming the posterior portion toward the sprue opening. After the stone (or plaster) has set, use two sprues from the flask opening to the most posterior portion of the wax on both sides (see diagram). Sprues should be approximately 7 mm. width. Do not create sharp angles with the sprues, as the heated resin must flow in a straight or slightly curved path. Apply a thin layer of petroleum jelly on the entire stone surface. Then invest top half of flask.

#### V. REMOVING WAX

After the stone has set, place flask in boiling water for 8 minutes. Open the flask and wash out the wax, making sure all wax residues are eliminated. Allow the flask to cool. Apply thin layers of separator on the entire surface of the stone and allow it to dry completely. Do not apply separator on teeth. When dry, close flask.

#### VI. INJECTING

Wear safety goggles and heat-protective gloves for this procedure.

Spray inside of the cartridge sleeve with mold release spray and place it into furnace. Turn on the furnace and allow it to reach approximately 550°F (290°C), preheating cartridge sleeve for approximately 15 minutes.

Remove cartridge from foil-lined bag (do not remove cartridge from bag until this step). Spray the cartridge and bronze disc with mold release spray. Insert the cartridge into the cartridge sleeve with the cap end first. Insert the bronze disc into the cartridge sleeve against the end of the cartridge. Use the thick bronze disc for medium tubes and the thin bronze disc for the large tubes. Heat cartridge for 12 minutes.

Position the flask with the sprue end up, directly under the shaft of the press. After 12 minutes, remove the cartridge sleeve from the furnace. Keep the cartridge sleeve in a horizontal position until resting on top of the flask, and then turn the cartridge sleeve into a vertical position. Immediately use the press to inject the heated cartridge into the flask using a steady fast motion. Continue applying pressure until tube bursts and continue with maximum downward pressure for 3 minutes.

Remove the cartridge sleeve from the flask with a slight twisting motion. After removing the cartridge sleeve, let the flask cool for at least 30 minutes. Do not put flask into a cold water bath. Use a plaster nipper to de-flask. Do not use a hammer. Remove the compressed cartridge from the cartridge sleeve with a knock-out punch. Important: Cartridge sleeve must be pre-heated for 10 minutes BEFORE the next injection.

#### VII. FINISHING AND POLISHING

Remove appliance from the model. Cut off the sprues with a cut-off wheel. Trim the edges of appliance with a coarse grinding wheel. Avoid overheating. Use rubber wheels to smooth scratches. Place the appliance on the articulated master model to check the fit, retention, thickness and occlusion. Clean the tissue surface with a small bristle brush.

To polish, use a coarse dental abrasive, such as pumice, with a wet rag wheel. Apply final shine with a hi-shine compound on low speed with a final buff wheel. Be careful not to overheat appliance.

## 铝桶

### Empty Aluminum Cartridge

编号 No.	规格 D x H, mm
25085	25 x 85 mm
25100	25 x 100 mm
25CAP	24.2 x 16 mm, Cap
22065	22 x 65 mm
22085	22 x 85 mm
22100	22 x 100 mm
22120	22 x 120 mm
22CAP	21.2 x 16 mm, Cap



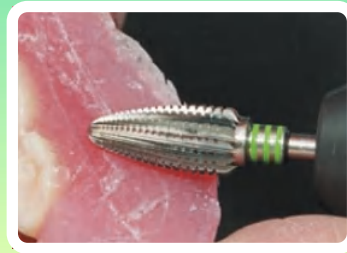
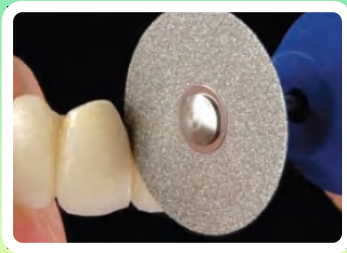

## 深圳市永昌源科技开发有限公司

ShenzhenYongchangyuan Technology Development Co., Ltd

地址: 广东省深圳市龙岗区平湖街道辅城坳社区金城路4号盛通云谷C座3楼

Address : 3rd Floor, Block C, ShengTong YunGu, JinCheng Rd., FuChengAo,

PingHu, LongGang Distr., 518000, Shenzhen, Guangdong Province, China

网站(Web): [www.kexinn.com](http://www.kexinn.com) ; 邮箱(Email): [inof@kexinn.com](mailto:inof@kexinn.com)

电话(Tel.): +86-755-89309291

手机(Mobile, Wechat, Whatsapp): +8613823370303 +8613149941313