

Thermal Imaging Camera Instruction Manual

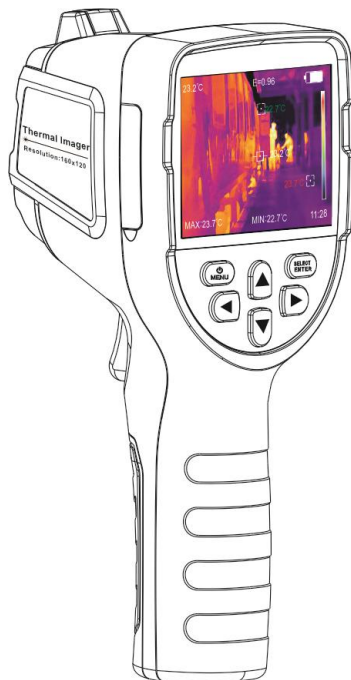

*Please read this user manual thoroughly before using
this meter and keep it handy for future reference*

Contents

| | |
|---|----|
| 1.Safety instruction..... | 1 |
| 2. Preliminary knowledge of thermal imager..... | 7 |
| 3.Overview..... | 8 |
| 4.Cleaning of the products..... | 9 |
| 5.Use Type C USB cable to charge:..... | 11 |
| 6、 Specifications..... | 12 |
| 7.Panel description..... | 14 |
| 8、 Display description..... | 15 |
| 9.Initial operation..... | 17 |
| 10.Introduction of the menu..... | 19 |
| 11.Troubleshooting..... | 32 |
| 12. Accessories..... | 33 |

1.Safety instruction

Please ensure that you have read and understood the safety precautions described in the following text before using the product so that you can operate it correctly.

The safety precautions described in the following text guides you to operate the product and its accessories correctly and safely to avoid damage and loss to you, other people and the device.



CAUTIONS:

Please observe the following guide in order not to damage the product:

- **Don't assemble or dismantle the product without permission.**
 - The product is a type of super precise equipment.
 - Don't try to dismantle, assemble or remodel any part of the product.
 - Repair of the product should be made by technical personnel designated by the distributors or agents.
- **Avoid damage to probe of the product**

Note: don't put the product close to strong heat source directly (such as electric iron).

- Otherwise, it may damage the probe of the product.

- If do not use the product for a long time, please put it in a cool and dry environment.
- If the product with battery is stored for a long time, please charge it regularly, otherwise the power will be exhausted and the battery life will be shortened.
- **Product hum**
- When the product works, there is light sound of clicking every several seconds.
- This is normal phenomenon that the lens captures images.



WARNINGS

- The warning describes the acts that may cause harm to users.
- Please observe the following operation in order to avoid electric shock or personal injury.



Warning: Don't aim the laser pointer at human or animal's eyes.

- The laser given out by the laser pointer may harm the vision.
- If the product case is damaged, don't use it continuously.
- During the process of use, if the product is found with

smoke, spark and the burnt smell, please stop using at once. In case of such condition, the product power supply should be powered off first.

- After the smoke and peculiar smell disappears completely, please contact the local distributors or agents.
- Do not use abrasive, isopropanol or gaseous organic solvent to clean the product shell.
- Such operation may damage the housing of the product.
- Don't remodel the adapter and the data line.
- Otherwise, such remodeling may cause short circuit or fire.

- **Don't weld the battery without permission.**

Such operation may damage the battery and result in leakage and explosion of the battery.

- **Avoid that the battery is impacted (such as collusion and falling, etc).**

Such condition may damage the battery case or result in that the battery leakage or explode.

- **Please pull off the adapter on the power socket when charging is not made.**

- The adapter may get overheated if it is connected with power supply for a long time.

- This may cause overheating, deformation and fire.
- **When the plug of the adapter or wire is damaged, stop using immediately.**

Don't change the battery unless the plug of the charger is inserted into the socket completely.

- **Please ensure that the plug of the adapter is inserted into the specified power socket.**
- The adapter plug may be different due to the regions.
- Please make confirmation whether the specification of the adapter is consist with the specification of electric appliances in your region.
- Otherwise, this may cause overheating of the equipment, electric shock, fire, chemical leakage inside the battery, explosion and other serious consequences.
- **Do not touch the electric wire with wet hands.**
- It is possible to cause electric shock when touching the electric wire with wet hands.
- When pulling out the electric wire, hold the electric wire head rightly to pull out the wire.
- Don't pull off the electric wire directly.
- Otherwise, the electric wire may be broken, causing electric shock and fire.
- **Forbid dip the product into water or caught in rain.**
- If the case contact with any liquid, please wipe it dry

immediately.

- If water or other liquid enters the inside of the instrument, please power off the power supply at once. Continuous use may result in product damage.
- **Clean the dust on the adapter plug and the data line.**
- When it is exposed to dusty and damp environment for a long time, the dirt surrounding the electric equipment will accumulate moisture.
- This may cause short circuit and fire.
- **Please use the original adapter of the company to charge the product.**
- The use of non-original power supply accessories may cause equipment overheating, electric shot, fire, and leakage of chemicals inside the battery, explosion and other serious consequences
- The product temperature may increase after a long time of charging.
- You may feel scorching heat when the hands touch the sensors.
- **Avoid that the product is impacted (such as collision and falling, etc).**
- Such operation may cause the product to be damaged.
- Please avoid such operation.
- **Long-time storage and regular charging.**

- The product should be placed at a cool and dry environment if it not used for a long time.
- If the product installed with battery is stored for a long time, charging should be made regularly.
- Otherwise, the battery will run out and the service life will be shortened.

● **Problem caused by water condensation**

- Don't bring the instrument into low temperature environment from high temperature environment in a short time or from low temperature environment to high temperature environment.
- This may result in that the inside of the instrument and appearance to be water condensation.
- In such condition, the instrument should be placed into portable box or plastic bag.

Before use, make it restore in the environmental temperature then take it out to use.

- If the product has water condensation inside, please power it off immediately.
- Otherwise, the instrument may be damaged.
- Operation is not allowed unless the water condensation disappears.

2. Preliminary knowledge of thermal imager

- For a long time, infrared thermal imaging detection technology has become an important means to ensure Industrial safety in developed countries.
- The application field includes electric power, metallurgy, petro-chemistry, machinery, coal, traffic, fire control and national defense, etc.
- It can not only carries out real-time detection at high voltage, high current and high speed operation to perform real-time detection for production and instrument but also need not power off the power supply, stop the machine or stop the production to find the potential problems and prevent occurrence of malfunction.
- The “non contact” modern detection technology is safe, reliable and quick.
- It is a type of technical revolution compared with traditional contact detection method.
- **The infrared thermal imaging technology is widely used in the following fields:**
 - The inspection of electric equipment, lines of transmission and transformers;
 - Search of concealed fire source in fire control;

- Personnel search and rescue and commanding at fire site;
- Make analysis of the leakage position and heat loss of thermal pipeline and heating equipment;
- Determine the position of heating failure of the operation train;
- Analysis of rationality of wire of microelectronic industry;
- Night monitoring of security departments.

3.Overview

- This product is an infrared camera that integrates surface temperature measurement and real-time thermal image.
- The traditional inferred thermometer needs to measure every component one by one while it is not necessary for infrared imaging camera, thus saving time.
- The potential problems may be displayed on color display screen clearly.
- Moreover, the central point measurement cursor is used to locate quickly and accurately to measure the temperature of the target object.
- In order to increase the differentiation, the product is

provided with a visible light camera.

- The thermal images and visible images are stored in the device and can be read through USB or stored in a computer to generate a report or for print.
- With small volume, the product is easy to operate and has strong function.
- It is the ideal selection for electric power, electronic manufacturing, industrial inspection and other fields.
- **The following major functions increase the product's accuracy and usability:**
 - The radiation coefficient may be adjusted to increase the measurement accuracy of objects with half reflection surface.
 - The highest temperature and lowest temperature cursor may guide the users to the areas with highest and lowest temperature of the thermal images.
 - The selectable color palette

4.Cleaning of the products

- Please use damp cloth or weak soap to clean the enclosure of the device.
- Don't use abradant, isopropanol or solvent to clean. Lens and screen should be cleaned by professional

optical lens cleaner

● **Lens maintenance**



Prevent damage of the infrared lens:

- Clean the infrared lens carefully.
- The lens is provided with refined anti-reflection coating.
- Don't clean with force to prevent damage of the anti-reflection coating.
- Please use cleaning solution for lens maintenance such as alcohol-containing commercial lens cleaning solution, alcohol or isopropanol as well as a piece of lint free cloth or paper tissue.
- The compressed air tank may be used to remove the loose particles.

● **Clean the lens:**

- The compressed air tank or dry nitrogen ion gun (if applicable) may be used to blow the loose particles on the lens surface.
- Dip the lint free cloth in alcohol.
- Squeeze the excessive alcohol in the cloth or apply the lint free cloth on dry cloth lightly.
- Wipe the lens surface by making circular motion.
- Then discard the cloth.
- If it is necessary to repeat above step, please use new cloth to dip with the cleaning solution to wipe.

5. Use Type C USB cable to charge:

- The product has built-in chargeable 18650 lithium batteries.
- When the battery level is low, the top right of the screen will display  Please charge in time through Type C interface.
- The top right of the screen will display “  ” when charging.
- The icon “  ” displays when the battery is fully charged.
- Pull off the USB line after fully charging.
- **To make the lithium ion battery can play the perfect performance:**
 - Don't place the battery on the charger exceeding 24 hours.
 - The thermal imaging device should be charged for two hours at least every three months so as to extend the battery life as long as possible
 - Don't try to charge the battery in extremely cold environment.

6、 Specifications

| | XE-31 | XE-32 | XE-33 |
|------------------------------|---|------------------------------|---------|
| Infrared image resolution | 160×120 | 220×160 | 320×240 |
| Infrared image resolution | 300,000 pixel | | |
| Display screen | 3.5" TFT color display | | |
| LCD resolution | 320×240 | | |
| Field angle | 35°×26° | | |
| Shortest focus length | 0.15m | | |
| Thermal sensitivity | 0.07°C | | |
| Temperature range | -20 to 450°C/ -4 to 842°F | -20 to 300°C/ -4 to 572°F | |
| Accuracy | ±2% or reading ±2°C/3.6°F | | |
| Emissivity | Adjustable from 0.01 to 1.00 | | |
| Frame rate of thermal images | 9Hz | | |
| Wavelength coverage | 8μm to 14μm | | |
| Focus mode | Fixed | | |
| Color palette | Rainbow, iron oxide red, cold color, black & white, white & black | | |
| Storage capacity | Built-in 3G (above 20 thousand | | |

| | |
|---------------------|---|
| | image stored) |
| File format | JPG |
| USB | Type-C |
| Battery | 18650 battery (Size: ϕ 18.5×69mm) |
| Working time | 2-3 hours |
| Automatic power-off | Selectable: 5 minutes/20 minutes/ not power off automatically |
| Language, | English、Chinese、Italian、German |
| size | 221×96×88mm |
| Weight | 374g |
| Work temperature | 0°C to 45°C/ 32 to 113°F |
| Storage temperature | -20°C to 60°C/ -4 to 140°F |
| Relative humidity | <85%RH |

Note: Adjustment may be required when you move the thermal imager between environments with large ambient temperature differences

7.Panel description

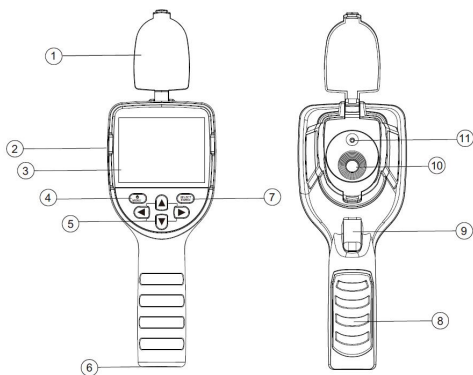

- ① Len cap (please open the cap in use)
- ② TYEP-C interface
- ③ LCD display
- ④ Power / Menu Key
- ⑤ Up/Down/Left/Right Key
- ⑥ Nut for tripod
- ⑦ SELECT Button
- ⑧ Battery cover
- ⑨ Trigger (Picture capture key)
- ⑩ Infrared imaging sensor
- ⑪ Visible light camera

8、 Display description

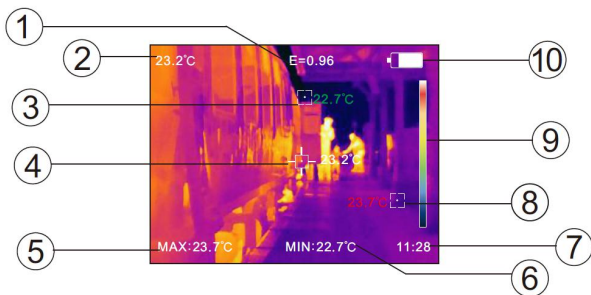

- ① Current emissivity
- ② Central point temperature
- ③ The lowest temperature cursor
- ④ Temperature cursor at central point
- ⑤ Maximum value
- ⑥ Minimum value
- ⑦ Time
- ⑧ The highest temperature cursor
- ⑨ Color code
- ⑩ Battery icon

1. Color code: used to mark the color corresponding to the relative temperature from low to high in the field of version.

2. The central point temperature cursor: used to indicate the central position in the screen area.

The cursor color displays white.

The temperature value is displayed top left corner of the screen.

3. The highest temperature cursor: used to indicate the highest temperature position in the screen area.

It will move with the movement of the highest temperature.

The cursor displays red.

The temperature value is displayed at the bottom of left screen.

4. The lowest temperature cursor: used to indicate the lowest temperature position in the screen area.

It will move with the movement of the lowest temperature.

The cursor displays green.

The temperature value is displayed at the center of bottom screen.

9.Initial operation

- **Power on/off**



Keep pressing “” for more than 3 seconds to power on or off the meter

- **LCD screen display**

After turning on the power, open the lens protection cover, the screen shows the thermal imaging status.

Note: Time adjustment may be required when you move the camera between environments with widely varying ambient temperatures



- **Switching between infrared thermal image and visible image**

press “” or “” key to switch the degree of fusion between infrared thermal images and visible images (the degree of fusion is 0%, 25%, 50%, 75% and 100%).

- **Image capture**

Press the trigger button one time, when the capture is successful, the screen will display “Save photo” .

If “yes” is selected, please press “” key or Trigger to save the image.

If “no” is selected, press “” key to “no”, then press “” key or Trigger to determine not to save the image.

- **The function to hide highest/lowest temperature column at the screen bottom**

Under the operation after normal start up, press “” key and the screen bottom will display highest/lowest temperature column.

Press “” can also hide it.

- **Image output**

The saved images through capture may be checked and output by connecting with a computer through Micro USB.

- **Read images**

Power the meter on, open the USB protective cover, use USB line to connect the USB port and the computer to read the images or save it into computers.

The supported operating system through verification includes: winxp, win7, win 8, win10, Apple system.

It is suggested to use the USB cable comes with the meter or USB cable with high quality.

Note: When connecting with a computer, pull off the data line after selecting “pop out device safely” to avoid causing file system damage and other problems.

If “unable to save” and other problems occur, you may find the hard disc in the computer and fix it.

10.Introduction of the menu

Press “” button the menu bar appears on the left, they are “Image registration” “Images” “Color palette” “Eimissivity” “Settings”



10.1“Image registration” Introduction

10.1.1 Description of image registration

Image registration makes it easier for users to understand the infrared images by using aligned visible images and infrared images.

The use of image overlapping can capture the visible image of every infrared image so as to display the temperature distribution in the target region correctly and share with other people more effectively.

10.1.2. Application of Image registration



Press the “” button to enter the main menu, and select “” (Image registration) in the main menu.

Press the “” button to enter the image registration adjustment mode. Press the navigation keys (up, down, left and right buttons) to perform the visible image shift operation.

Press the “” button to exit the image blending mode (Note: If there is no operation for more than 6 seconds, the image blending mode will be automatically exited).



10.2 Introduction to “image” sub-menu

10.2.1 View image

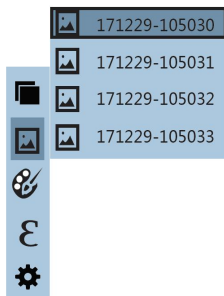

Press the “” button to enter the main menu, and select “” (Image) in the main menu.





As shown in the figure, then press “” button to enter image list.

Press “” or “” key in navigation to select the image.

Then press “” key to view image.

When viewing the images, press “” key to view the previous image, Press “” to view the next image.

Press “” key to return.

Press “” key to exit from the menu.

10.2.2. Delete images

When viewing the images, if pressing “” key, the screen will show the prompt of “Delete photo? ”

If “yes” is selected at the moment, press “” key to determine to delete the image.

If “no” is selected, press “” key to “No” and press “” key to determine not to delete the image.

10.3 Introduction of “color palette” sub-menu

10.3.1 Color Palette Description

The menu of color can change the false color of infrared thermal image.

Some color palette are better suited for specific applications and can be set as needed.

There are 5 color palettes : rainbow, iron red, cool, white hot and black hot.

These palettes are most useful for high thermal contrast and provide additional color contrast between high and low temperatures.

Suitable selection of color palette displays the details of the target objective better. Rainbow, iron oxide red and cold color palettes focus on display of color.

Such color palettes are very suitable for high heat contrast and are used to improve the color contrast between high

temperature and low temperature.

While the black & white and white & black color palettes provide even linear color.

The following is the image of the same object with selection of different color palettes.

Rainbow

Iron

Cool



White

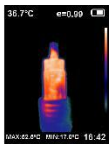
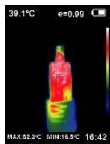

Black



10.3.2 Application of color palette



As shown in the figure, press “ MENU ” key to enter the main menu and select “ ” (color palette) option and press “ ” button to enter the color palette list.

Press “” and “” keys in navigation to select the color palette.

Then press “” key to select the color palette.

Press “” to return.

Press “” key to exit from the menu.

10.4 Introduction of “emissivity” sub-menu

10.4.1 Emissivity description

The emissivity of the product can be adjusted from 0.01 to 1.00 with the default value of 0.95.

Many common objects and materials (such as timber, water, skin and textile fabric) can reflect the heat energy effectively. So it is easy to obtain relatively correct measurement value.

The emissivity is usually set as 0.95 when the coarse objects that are easy to give out energy.

For semi-matte objects that give out less energy, the emissivity is usually about 0.85 and the emissivity of semi-gloss objects is 0.6.

The shiny objects are divided into materials with low radiation coefficient.

The emissivity is usually set as 0.3 at the time of measurement. Correct setting of the value of emissivity is very important for you to carry out the most correct temperature measurement.

The surface emissivity will produce giant impact on surface

temperature measured by the product. Understanding the surface emissivity will enable you to obtain correct temperature measurement result.

10.4.2 Emissivity setting

The product is provided with four types of object measurement modes:

Coarse object (0.95)

Semi-matte object (0.85)



Semi-shiny object (0.60)

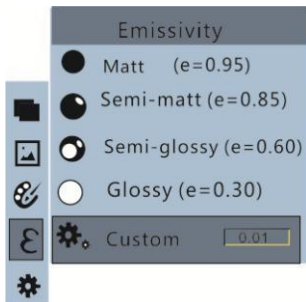

Shiny object (0.30)

According to the characteristics of the measured objects, users may set the emissivity value through the “self-define” option (please refer to the table of “emissivity of common materials”).

The operating step is as the following:







As shown in the figure, press “” key to enter the main menu and select “” (emissivity) option and press “” button to enter the emissivity list.



Press “” and “” keys in navigation key to select the emissivity.

Then press “” key to determine selection of the emissivity.

Press “” key again to return.

If you select "self-defined" emissivity, press the “” button to enter the editing state.

Press “” / “” keys to select the number to be changed, press “” “” keys to change the value.

After the modification is completed, press “” to confirm, then press “” to return.







Press “” button to exit the menu.

10.4.3 The emissivity value of common materials



| Substance | Thermal radiation | Substance | Thermal radiation |
|-----------|-------------------|-----------------------|-------------------|
| Bitumen | 0.90~0.98 | Black cloth | 0.98 |
| Concrete | 0.94 | Human skin | 0.98 |
| Cement | 0.96 | Foam | 0.75~0.80 |
| Sand | 0.90 | Charcoal dust | 0.96 |
| Earth | 0.92~0.96 | Paint | 0.80~0.95 |
| Water | 0.92~0.96 | Matte paint | 0.97 |
| Ice | 0.96~0.98 | Black rubber | 0.94 |
| Snow | 0.83 | Plastic | 0.85~0.95 |
| Glass | 0.90~0.95 | Timber | 0.90 |
| Ceramics | 0.90~0.94 | Paper | 0.70~0.94 |
| Marble | 0.94 | Chromium hemitrioxide | 0.81 |
| Gypsum | 0.80~0.90 | Copper oxide | 0.78 |
| Mortar | 0.89~0.91 | Ferric oxide | 0.78~0.82 |
| Brick | 0.93~0.96 | Textile | 0.90 |

10.5”(setting) option in the main “” .



Press “” button to enter the “setting” sub-menu.

| Settings | | |
|---|---------------|---|
|  Auto shutdown ▶ | Auto shutdown | NO 5min 20min |
|  Intensity ▶ | Intensity | Low Medium High |
|  Language ▶ | Language | English Chinese Italian German |
|  Unit ▶ | Unit | Celsius Fahrenheit |
|  Time format ▶ | Time Format | 24 hour AM/PM |
|  Set time ▶ | Set time | Year 2017 Month 12 Day 28 Hour 15 Minute 15 Second 15 |
|  Spot ▶ | Spot | Off On |

10.5.1 Auto shutdown setting



After entering the "Settings" sub-menu, select ""
(automatic shutdown), press navigation “” button
enters the auto power off setting.



Can be set not to automatically shut down or 5 minutes or 20



minutes to turn off automatically. press “” to confirm, then press “” to return.

Press “” button to exits the menu

10.5.2 Brightness Setting



After selecting “” (brightness), press the “” button in the navigation key to enter the brightness setting.



Press “” “” to set low or medium or bright.



press “” to confirm, then press “” to return.

Press “” button to exits the menu.

10.5.3 Language settings



After selecting “” (language), press the “” button in the navigation key to enter the language setting.

Press “” “” to set English, Chinese, Italian, German..



press “” to confirm, then press “” to return.

Press “” button to exits the menu.

10.5.4 Unit setting



After selecting “” (Unit), press the “” button in the navigation key to enter the unit setting.

Press “” “” to set Celsius and Fahrenheit. press



“” to confirm, then press “” to return.

Press “” button to exits the menu.

10.5.5 Time format setting

After selecting “” (Time Format), press the “” button in the navigation key to enter the time format setting.

Press “” “” to set 24 hours or 12 hours (AM/PM).

press “” to confirm, then press “” to return. Press “” button to exits the menu.

10.5.6 Set time

As shown in the figure, after selecting “ ” (set time), press “ ” in the navigation key to enter the setting time.

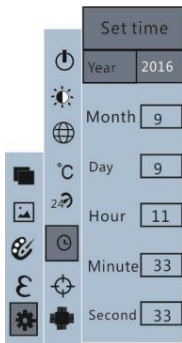

Press “ ”/“ ” to select year/month/day/hour/minute.

After selecting, press “ ” key to enter the edit state.
Press “ ” and “ ” keys to select the figure to be changed.

Press “ ”/“ ” key to change the value.

After completing the change, press “ ” to enter.

After the time setting is completed, press “ ” key to return.



Press “ ” exit from the menu.

10.5.7 Enable/disable of the highest and lowest temperature cursor

As shown in the figure, after selecting “” (cold hotspot), press the

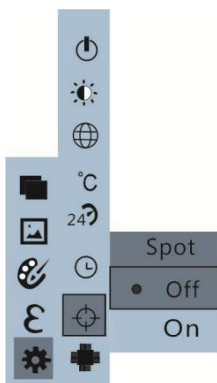
“” button in the navigation key to enter the cold hotspot setting.



Press “” / “” key to select “on” or “off” the option.

Then press “” key to determine selection.

After the setting is completed, press “” key to return.

Press “” key to exit from the menu.

11.Troubleshooting

If you encounter with any problem when using the thermal image device, please use the following table for repair.If the problems are not solved, please cut off the power supply and contact with the manufacturer.

| Failure phenomenon | Failure cause | Solution |
|---|---|---|
| The thermal imaging device cannot start | The battery is not installed | Install the battery |
| | The power of the battery is used up | Replace with new battery or charge it |
| The thermal imaging device powers off automatically | The power of the battery is used up | Replace with new battery or charge it |
| | The time set for automatic power off is due | Restart or change the time for auto power off after restarting (refer to 5.1) |
| No thermal images | The lens cover is not opened | Open the lens cover |

12. Accessories

- 1) Thermal imager
- 2) Type-C USB Cable
- 3) Adaptor
- 4) User's Manual
- 5) Canvas bag
- 6) Gift box

