

METAL CEILING

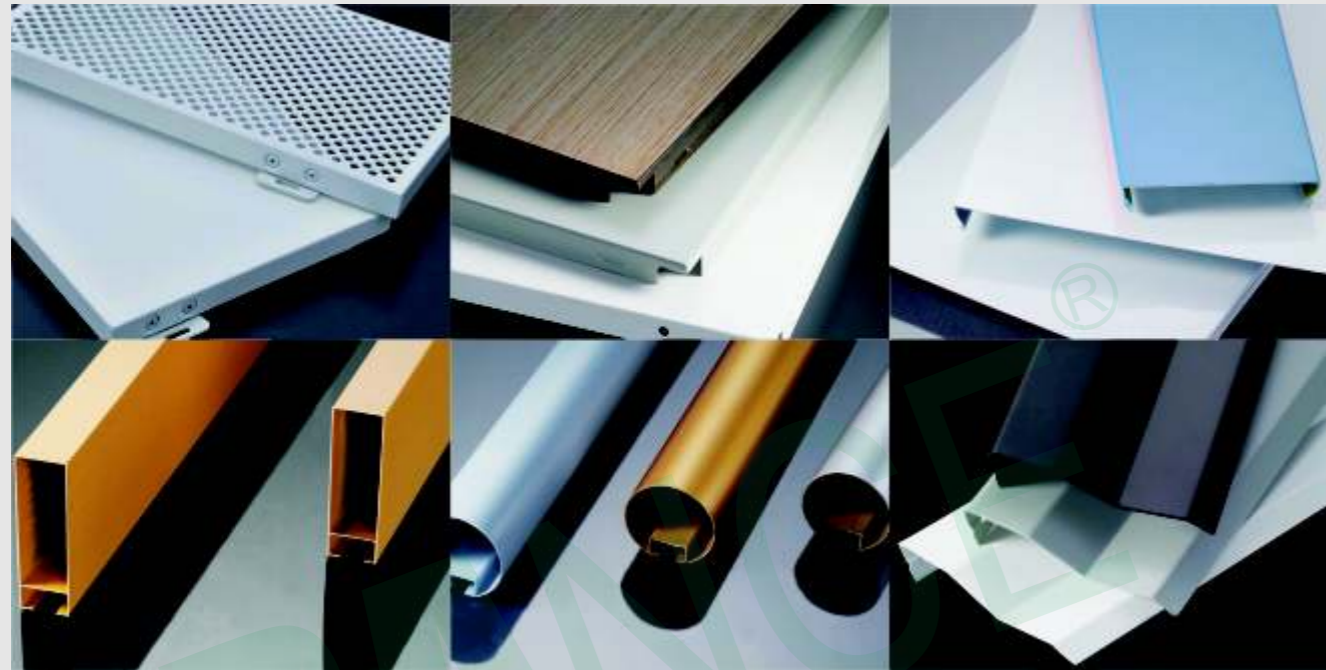

- SQUARE CEILING SERIES
方板天花系列
- SQUARE TUBE CEILING SERIES
方管天花系列
- OPEN CEILING SERIES
格栅天花系列
- STRIP CEILING SERIES
条扣天花系列
- BLADE CEILING SERIES
挂片天花系列
- O-SHAPED CEILING SERIES
圆管天花系列
- CORRUGATED CEILING
瓦楞板
- NON-STANDARD CEILING SERIES
非标板天花系列



Specification 产品规格	Perforation 冲孔	Powder coating 粉末喷涂	Roll-painting 辊涂	Ledge 直边	Beveled edge 斜边	Height 边高
300X300	●	●	●	●	●	18/20
300X600	●	●	●	●	●	20/24/28
300X1200	●	●	●	●	●	20/24/28
400X400	●	●	●	●	●	20/24/28
500X500	●	●	●	●	●	20/24/28
600X600	●	●	●	●	●	20/24/28
600X1200	●	●	●	●	●	20/24/28
800X800	●	●	●	●	●	20/24/28

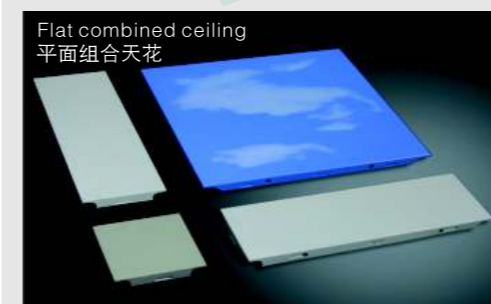

300配100组合(直边) 300+100(L angle)				600配150组合(斜边) 600+150(beveled angle)			
300×300	方板	ceiling tile	ceiling tile	600×600	方板	ceiling tile	ceiling tile
100×100	小方盒	square box	square box	150×150	小方盒	square box	square box
100×300	长方盒	strip box	strip box	150×600	长方盒	strip box	strip box

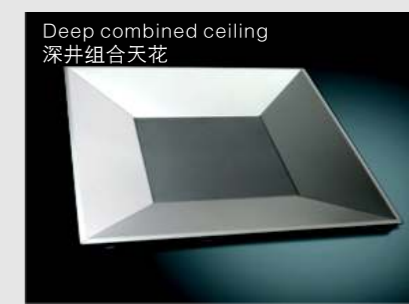

600+100(Langle)				600+150(L angle)			
600×600	井框	frame	frame	600×600	井框	frame	frame
300×300	井盖	cover	cover	300×300	井盖	cover	cover
100×100	小方盒	square box	square box	150×150	小方盒	square box	square box
100×300	长方盒	strip box	strip box	150×600	长方盒	strip box	strip box

CLIP IN CEILING
暗架方板天花系列

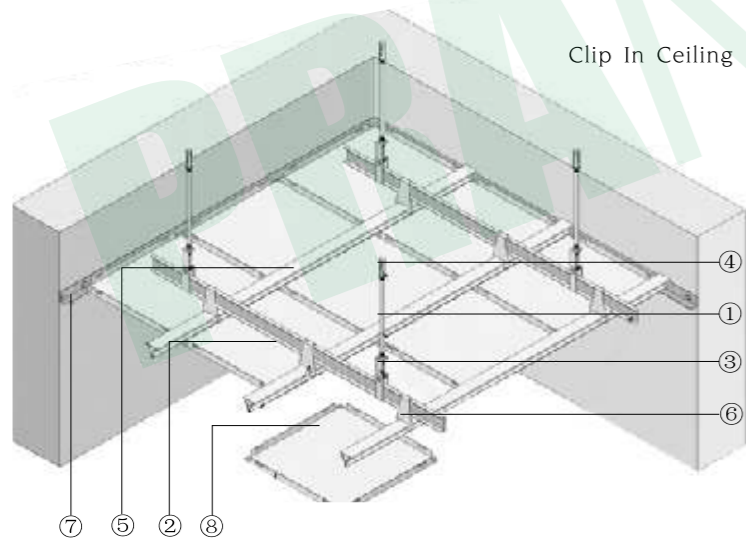

- ①hanging bolt
- ②38main profile
- ③hanging parts of 38 main profile
- ④explosive bolt
- ⑤triangle profile
- ⑥hanging parts of ⑤
- ⑦wall angle
- ⑧square panel

- ①螺杆
- ②38龙骨
- ③38龙骨吊件
- ④爆炸螺丝
- ⑤三角龙骨
- ⑥三角龙骨吊件
- ⑦收边角
- ⑧方板天花



LAY IN CEILING
明架方板天花

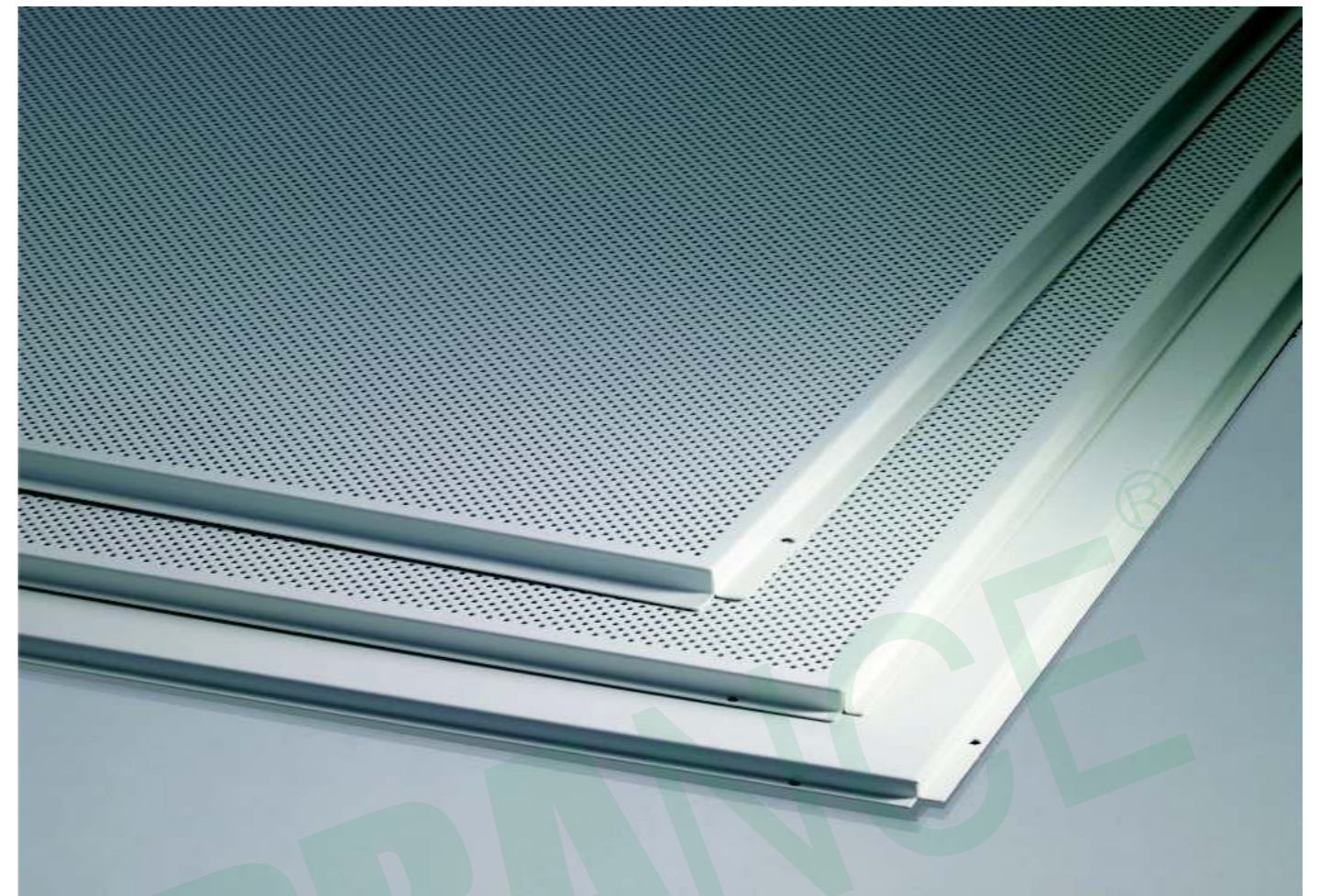

Lay in ceiling
明架方板天花

Lay on ceiling 明架平面天花	595x595x18Hmm	Lay in ceiling 明架跌级天花	Metric system 公制	British system 英制
	603.25x603.25x18Hmm		595x595x575x575x8Hmm(12H/18H)	605x605x585x585x10Hmm
	295x295x10Hmm		595x595x585x585x10Hmm	585x585x575x575x8Hmm
			595x1195x575x1175	603x1210x585x1195
			295x295x275x275x8H	

安装方法 Installation

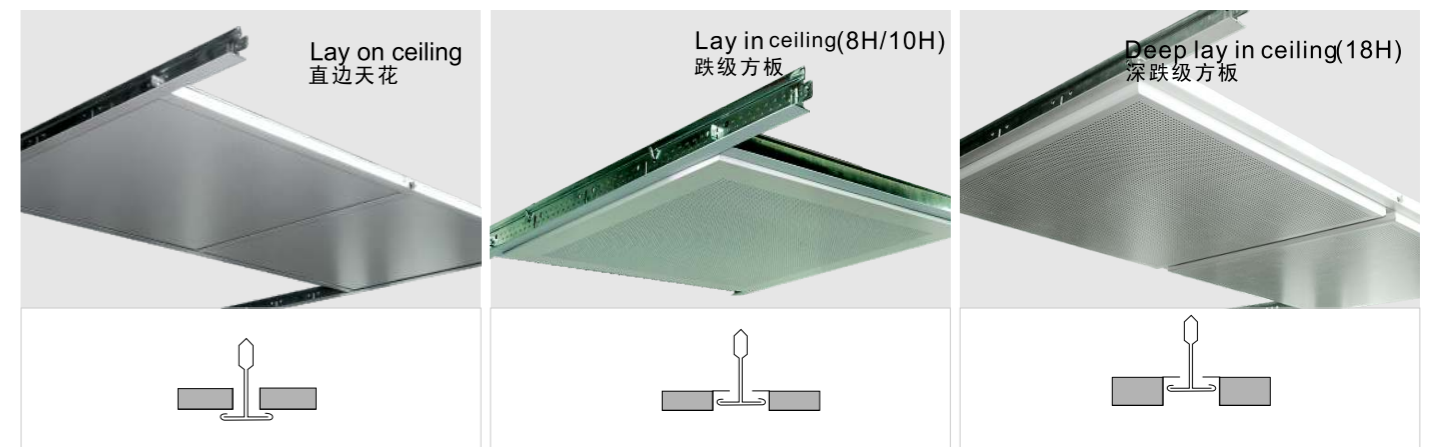

800 CLIP IN PATENT CEILING 800系列外观专利工程板



800X800斜边平板



800X800井型

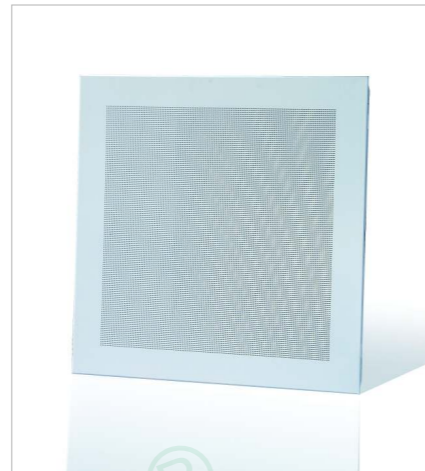

800X800斜边四边留白 φ2.3

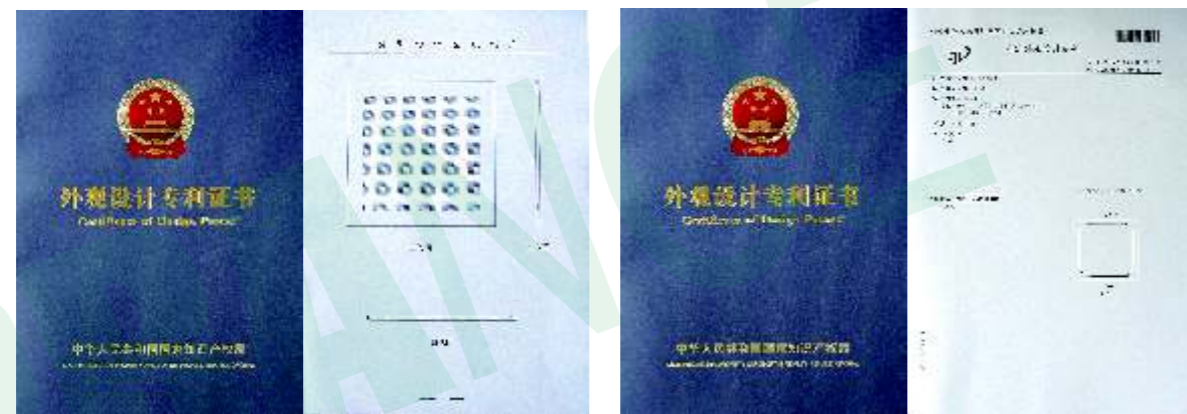

质量认证证书 CERTIFICATE



Specification(mm)

产品规格	冲孔	粉末喷涂	聚酯辊涂	直边	斜边	边高
300X300	●	●	●	●	●	20
300X600	●	●	●	●	●	20
300X1200	●	●	●	●	●	20
400X400	●	●	●	●	●	20
500X500	●	●	●	●	●	20
600X600	●	●	●	●	●	20/24/28
600X1200	●	●	●	●	●	20/24/28
800X800	●	●	●	●	●	24

冲孔数据 Perforation size

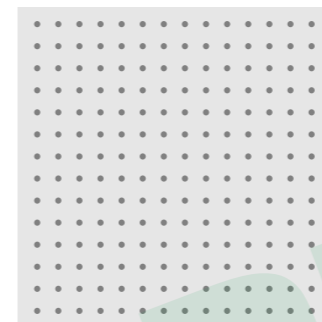

孔径 hole size:0.8mm直排孔

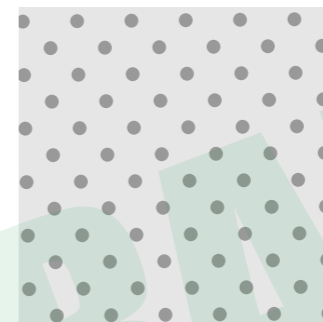

孔径 hole size:1.8mm斜排孔

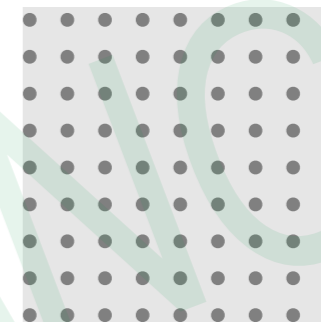

孔径 hole size:1.8mm直排孔

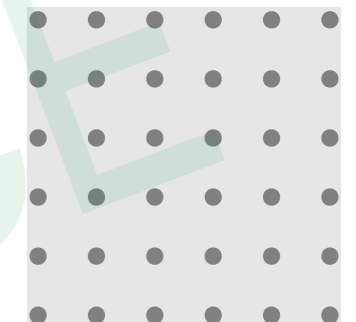

孔径 hole size:2.3mm直排孔

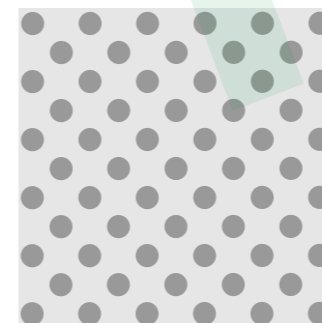

孔径 hole size:3.0mm斜排孔

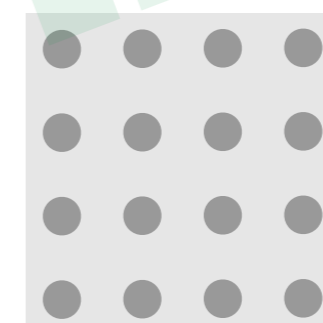

孔径 hole size:5.0mm直排孔

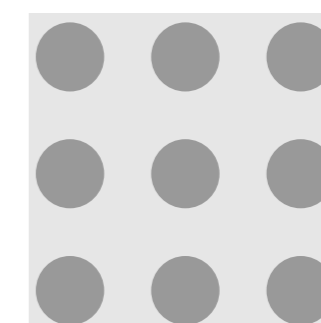

孔径 hole size:10mm直排孔

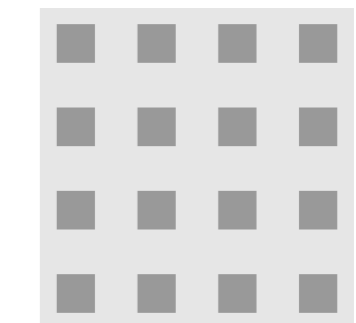

孔径 hole size: 5mm直排孔

方板天花板有多种冲孔图案可供选择，冲孔天花板背面加入隔音纸或隔音棉，有助于增加整个密闭空间的总吸收容量，降低噪音给我们带来的影响。上图所示为不同冲孔形式的资料，每款冲孔形式均可提供不同的吸引开放面积比率（冲孔率），达到不同程度的密闭空间吸音需求。

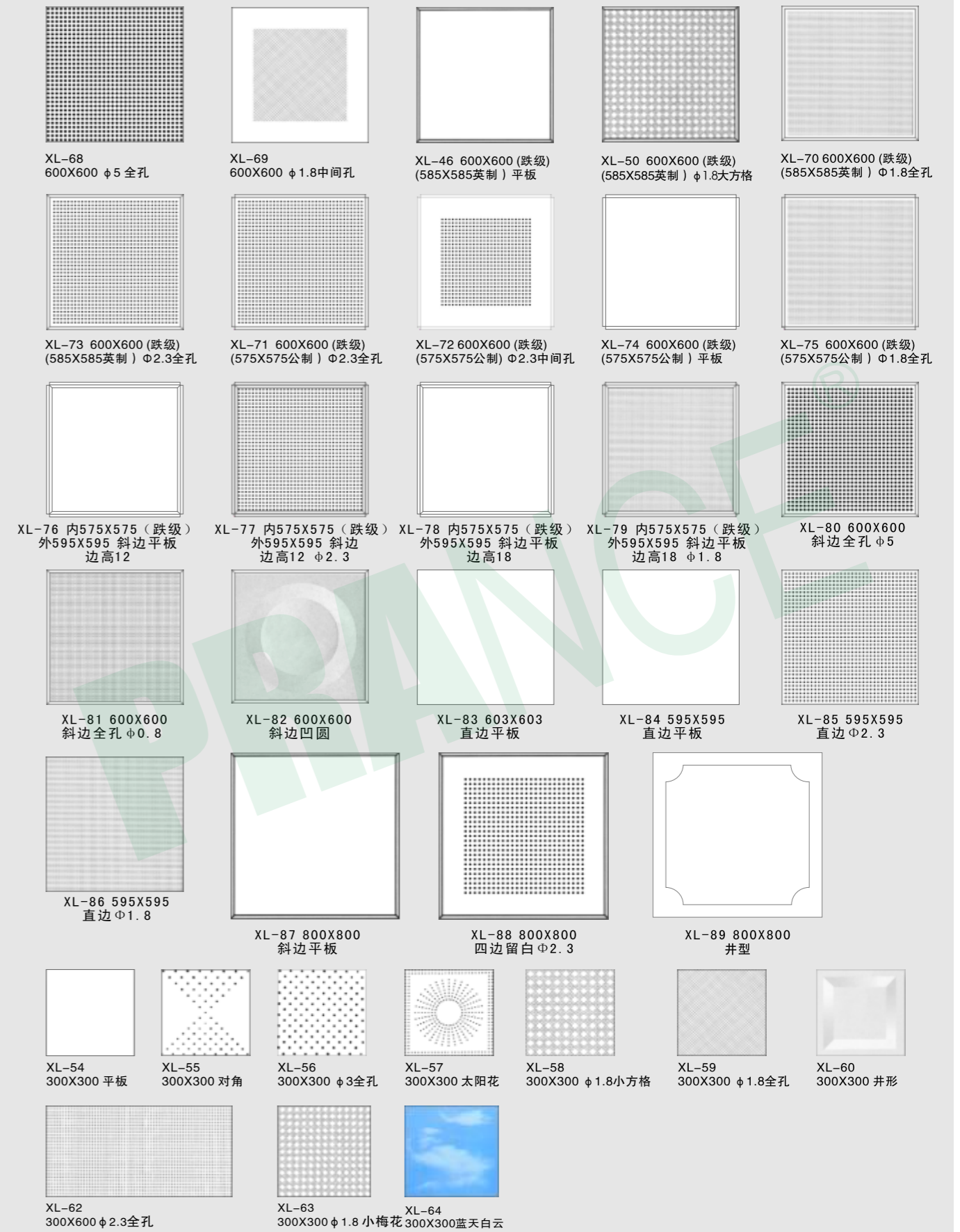
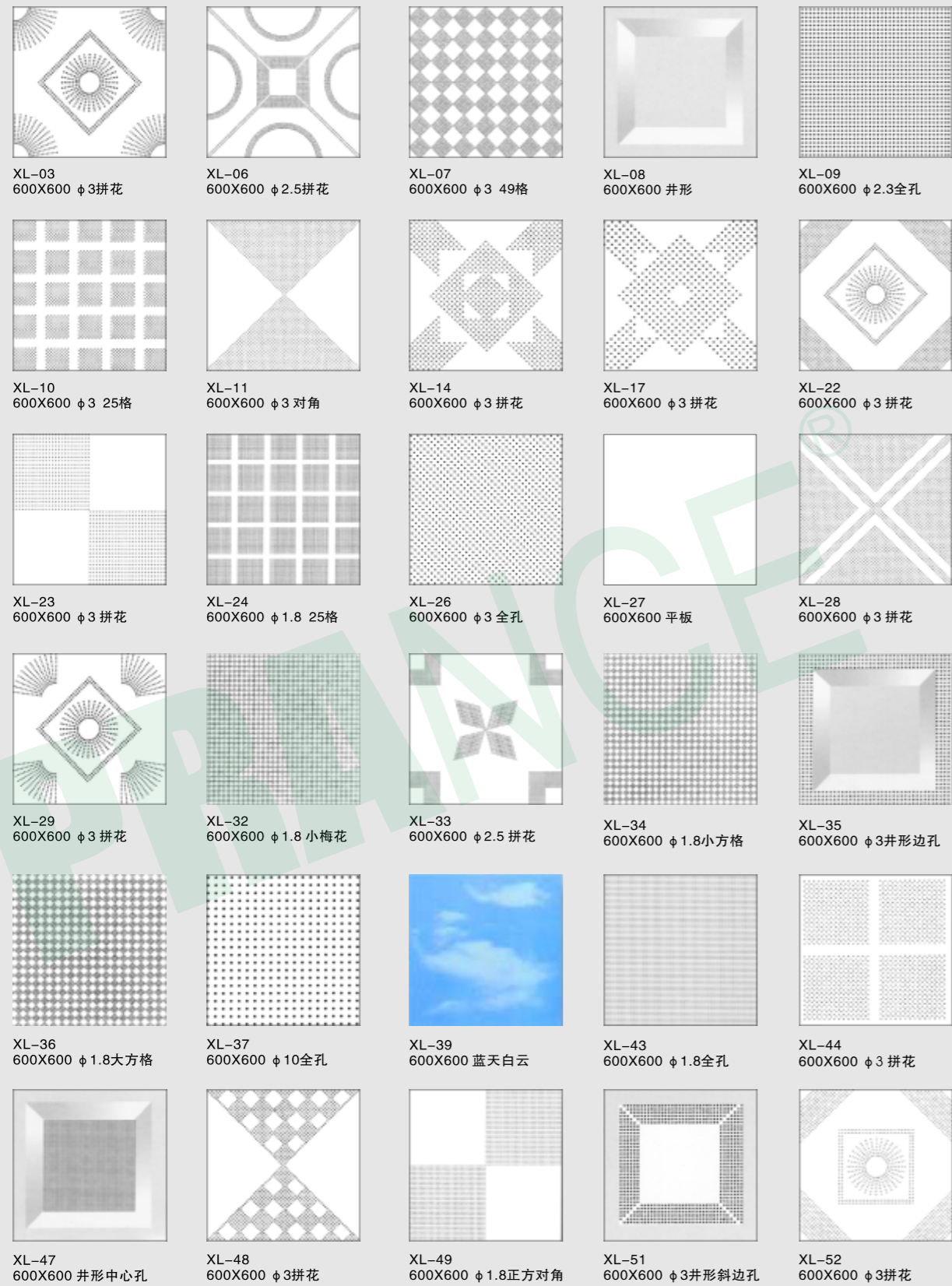

Product patterns just for reference,
Make order should be on the basis of samples
产品图案仅供参考,定货以实样为准

OPEN CEILING

■ 格栅天花系列



■ 格栅天花规格尺寸 Specification

Open size (mm) 方格尺寸	Width & height 宽和高	Length 长度	Thickness 厚度
50X50	W10:H35/40/45/50 W15:H50/60/80	2000	0.35~0.6
75X75	W10:H35/40/45/50 W15:H50/60/80	1950	0.35~0.6
100X100	W10:H35/40/45/50 W15:H50/60/80	2000	0.35~0.6
125X125	W10:H35/40/45/50 W15:H50/60/80	2000	0.35~0.6
150X150	W10:H35/40/45/50 W15:H50/60/80	1950	0.35~0.6
200X200	W10:H35/40/45/50 W15:H50/60/80	2000	0.35~0.6

■ OPEN CEILING 格栅天花系列

PRANCE®

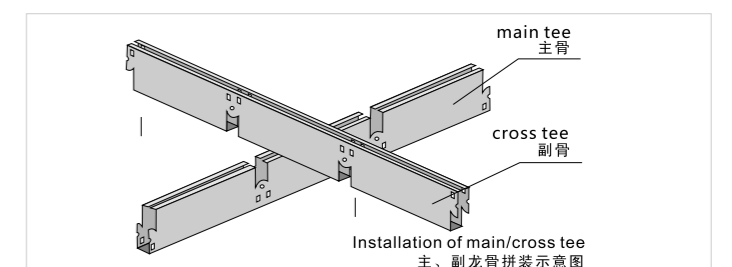
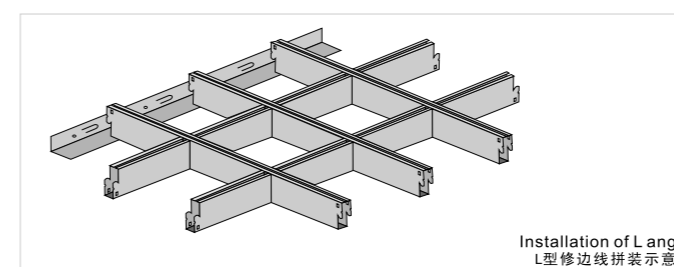
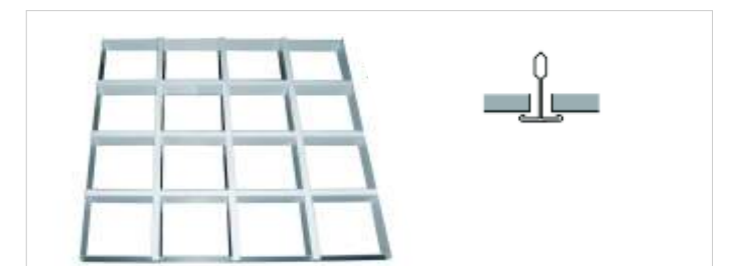
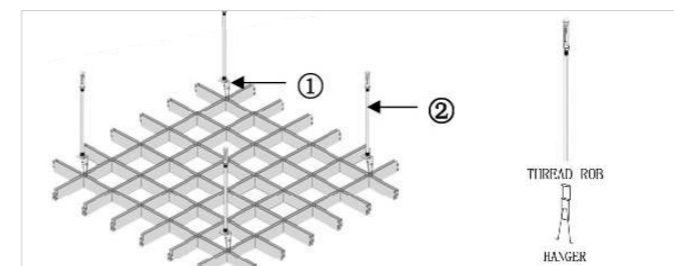
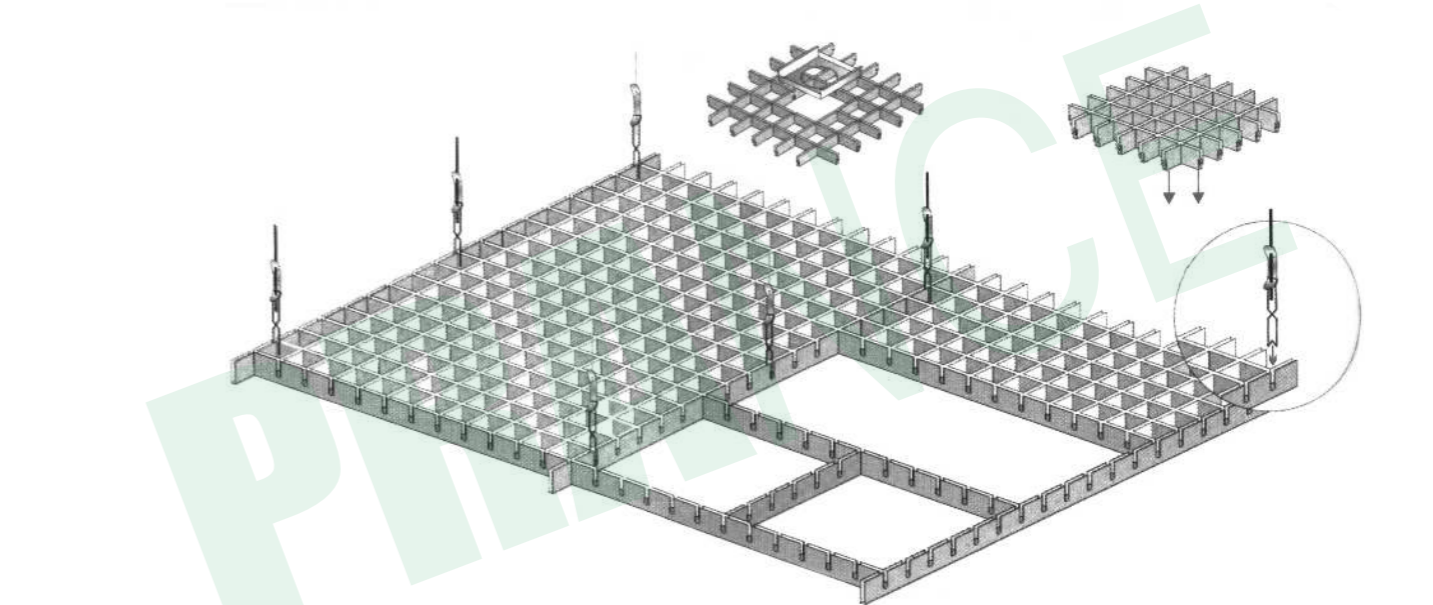

SQUARE TUBE CEILING

方管天花系列

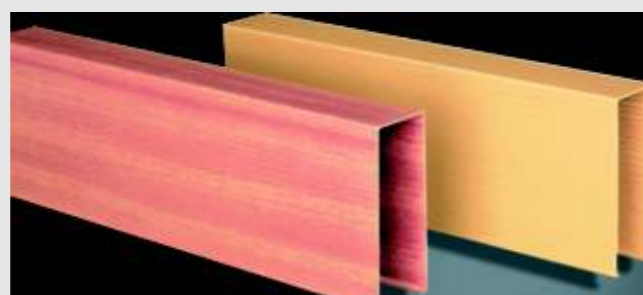

空间应用:

Space application:

适用于地铁, 车站, 机场, 加油站, 医院, 博物馆等大型工程。

Suitable for hospitals, Metro, station, airport, gas station, museum and other large engineering.

U-square Tube Ceiling

折弯型方管天花

方管天花规格尺寸 Specification

宽度 Width	长度 Length	厚度 Thickness
30	1000-5000	0.7-1.2
40	1000-5000	0.7-1.2
50	1000-5000	0.7-1.2

注: 如有非标尺寸, 可按图纸要求订制。special size could in needs 单位: mm

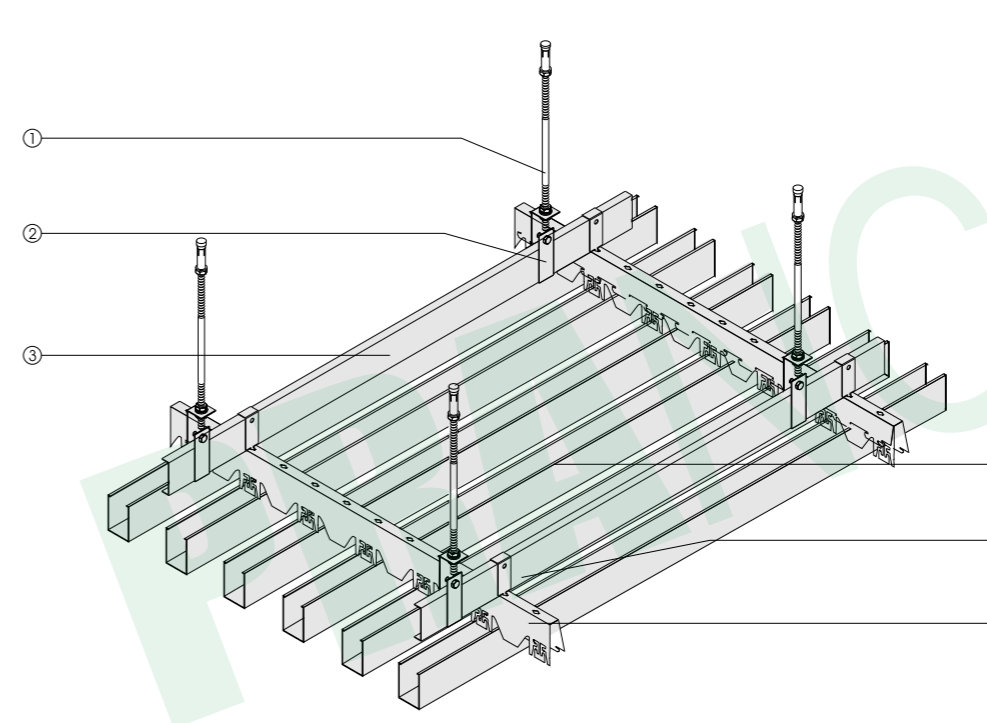

- ① Thread rod
螺杆
- ② Hanger for m
38主龙骨吊件
- ③ Main channel
38主龙骨
- ④ Square Tube Ceiling
方管天花
- ⑤ Hanger for Spring tee
龙骨吊件
- ⑥ Spring tee
方管龙骨

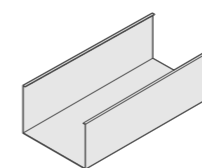

1 square flat tube ceiling

Materils: Grade AA aluminum alloy
Processing of surface: Powder coating
Specification: 20-50
Standard thickness: 0.8-1.2mm

方管天花

材料: AA级铝合金
表面处理: 静电粉末喷涂
规格: 20-50mm
标准厚度: 0.8-1.2mm



square tube carrier

Materils: Steel
Processing of surface: Zincification or black polyester
Height: 30-40mm
Length: 3000mm
Standard thickness: 0.7mm

方管龙骨

材料: 钢
表面处理: 镀锌或聚酯黑色
高度: 30-40mm
长度: 3000mm
标准厚度: 0.7mm

PRANCE PROFILE SQUARE TUBE CEILING 型材方管天花

规格尺寸 Specification

名称 Item	宽度 Width	长度 Length	高度 Height	厚度 Thickness
P01-A 100XL	30	3000-6000	100	1.0
P01-B 150XL	30	3000-6000	150	1.2
P01-C 200XL	30	3000-6000	200	1.5

注：如有非标尺寸，可按图纸要求订制。 special size could in needs 单位：mm

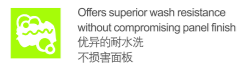

Offers superior wash resistance without compromising panel finish
优异的耐水洗，不损害面板



Excellent resistance to dirt and/or grease; for lasting and performance.
优良的抗污垢/油脂，持久性能。



Impact Resistance Excellent resistance to surface impact as per Falling Ball Test
耐冲击性优良表面，根据落球冲击试验。



Withstands up to 150 scrub cycles
承受高达150磨砂周期



minimizes panel damage
最大限度地减少面板的损坏。



Color options
颜色可选

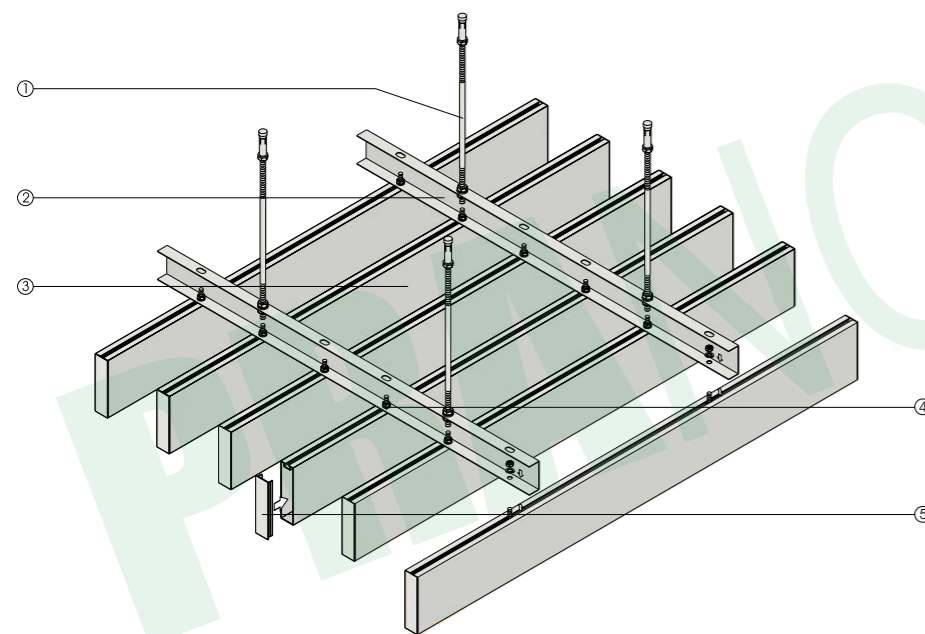

- ①M8 Thread rod
- ②C Slot Carrier
- ③Square-Shaped Aluminum Bar
- ④M6 Screw
- ⑤Side Cover
- ①M8吊杆
- ②槽龙骨
- ③方型铝通
- ④M6螺丝
- ⑤方型铝通封头盖

龙骨连接图

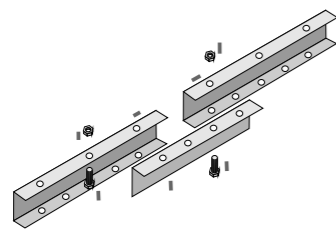

方管边盖示意图

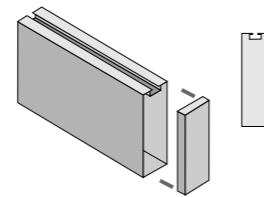

方条型吊式天花吊挂系统示意图

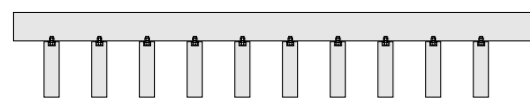

方条型吊式天花截面示意图

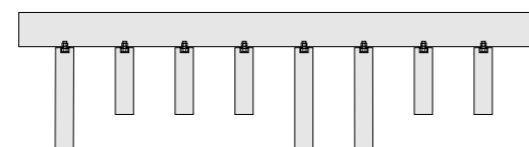

高低组合截面示意图

型材方管天花：
采用优质2003铝合金板
状态：H24
厚度：0.6~1.0mm
表面处理：粉末喷涂或聚酯辊涂
安装：暗装龙骨系统吊装

Profile square tube ceiling:
The quality of 2003 aluminum alloy plate
State: h24
Thickness: 0.4~1.0mm
Surface treatment: powder coating or Polyester coating
Installation: lifting t keel system

