

TGW-WT009D Flap Turnstile



Stainless Steel Flap Turnstile

Function:

1. The working mode can be set through the button on the main panel.
2. Anti-collision, the object will automatically and slowly return to the original position after collision, to prevent the motor from being damaged by external force collision.
3. Doors can be synchronized.
4. Automatic reset. Right turn is automatically cancelled if it is not passed within the scheduled time. (1-60s adjustable), the default time is 10s.
5. Compatible access control system, consumption system, ESD system, electronic ticketing system, etc.
6. One-way control or two-way control.
7. One pair of anti-collision infrared sensor, two pairs of alarm infrared sensor.
8. Each cabinet has one LED direction indicator.
9. The unit can be controlled and managed by remote control.



Extensible functions:

1. LED counter display
2. Cabinet and swing arms can be lengthened.
3. Two or more pairs of extensible anti-collision infrared sensor, customizable.
4. Voice prompts

Dimensional drawing:

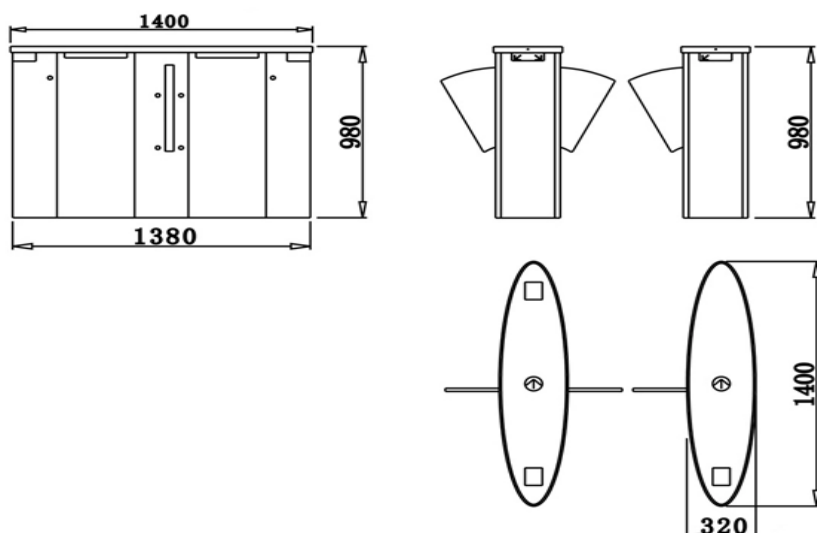

Parameters:

Cabinet Material	304 Stainless Steel
Dimensions	1200*300*980mm
Weight	80KG
Motor Type	Double motor
Flap Barrier Material	PVC/Acrylic
Arm Length	≤ 300mm
Passage Width	≤ 600mm
Opening Signal	Relay
Material Thickness	1.5mm
Card-reading Window:	Two
Infrared sensor	3Pairs
Protection function	Infrared anti-pinch,Break-in alarm function
Direction	Bi-directional
Service Life	5million times
Operating Temperature	-25°C ~ +60°C
Related Humidity	≤ 90%RH
Communication Interface	TCP/IP
Power Rate	90W
Power Supply	AC 220V/110V ±10% 50/60MHZ (optional)
Opening Speed:	30-45persons per minute

Application:

Flap Turnstile

1. Can be compatible with IC /ID card, bar code card, fingerprint and face recognition access control method.
2. Used for staff, provide civilized, orderly access methods; effectively manage the access of staff.
3. Can be widely used in the sports stadiums, amusement parks, and university facilities for access management.